

Lab 2: Reflections on Transmission Lines

In this lab you are going to simulate reflections on transmission lines to predict the types of voltages you would see at drivers, loads and selected points in the middle of a transmission line.

After this lab, you will be able to:

1. Calculate reflection coefficients and voltage distributions on transmission lines.
2. Predict the time scales and shapes of reflection events at the driving point and load of a transmission line
3. Simulate voltages produced at the terminals of a lossless transmission line.
4. Measure transmission line transients in the lab, and understand what practical features of lab equipment affect those transients.

Practical Questions

1. We have looked at transmission lines in the abstract in our lectures. This round of practical questions will focus on finding examples of transmission lines that are used in the real world. Find pictures and/or cross-sections for each of the following common transmission lines:
 - a. BNC cables (for the record, our BNC cables are of type RG58/U)
 - b. SMA cables
 - c. Microstrip PCB Traces
 - d. (Grounded) Coplanar waveguide PCB traces. It is very rare to see an ungrounded CPWG
 - e. Stripline PCB traces
2. What is loss tangent? Find a calculation relating loss tangent to the real part of the propagation constant. (If it helps, assume the loss tangent is the dominant source of loss in the cable.)
3. FR4 is common material used to make PCBs.
 - a. What is the relative permittivity of FR4?
 - b. How does the relative permittivity affect the speed of light in FR4?
 - c. How does the relative permittivity of FR4 affect the velocity factor of transmission lines built on FR4 PCBs?
 - d. What is the maximum frequency signal that FR4 PCBs can handle and why?
4. What does the word Stackup mean in the context of printed circuit boards? What is the stackup of standard 4-layer printed circuit boards ordered from the manufacturer Advanced Circuits? What effect does the stackup have on transmission lines designed on boards fabricated by Advanced Circuits?
5. What is electrical length?
6. The velocity factor of transmission lines is well defined, but velocity factor in connectors is poorly defined. Sometimes you can the delay of connectors by pretending they add a little “virtual length” to the wires they are attached to, but you need to extract that virtual length with experiments. Devise an experiment that will let you figure out the virtual length of a connector, you are allowed to use a signal generator, an oscilloscope, and as many lengths of wire as you’d like. Assume you don’t know the velocity factor of the wire.

Theory Questions

For these questions, note that BNC cables have a velocity factor of 0.66 and a characteristic impedance of 50 ohms. Note also that function generators almost all have 50 ohms of source impedance.

1. Consider an oscilloscope and function generator connected as shown in Figure 1. Calculate the voltage waveforms you expect to see at channels 1, 2 and 3 after Gen Out drives a 1V step onto the transmission line for the terminations listed below.
 - a. An open circuit
 - b. 50 ohms.
 - c. A short circuit
 - d. 22 ohms
 - e. 200 ohms

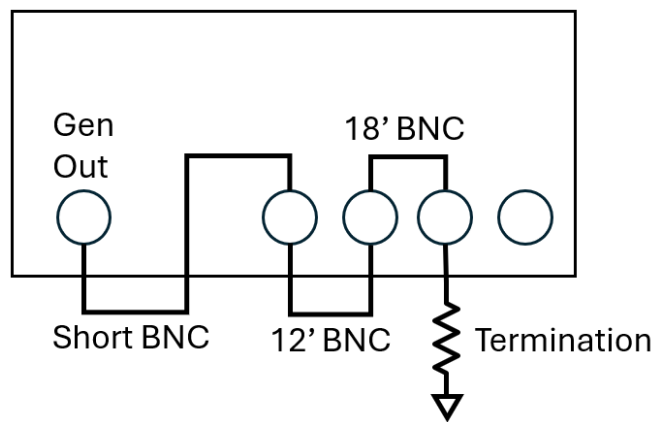

Figure 1

2. Consider an oscilloscope and function generator connected as shown in Figure 2. Calculate the voltage waveforms you expect to see at channels 1, 2 and 3 after gen out drives a 1V step onto the line for the values of shunt and termination resistors listed below.
 - a. 50 ohm shunt and 50 ohm termination ← hint: think about energy conservation
 - b. 50 ohm shunt and 200 ohm termination ← don't solve this exactly because it's a longwinded pain, a general discussion of what happens at the first few reflections and the point to which the line voltage converges is OK.
 - c. Short shunt and open termination
3. Finally, consider an oscilloscope and function generator connected as shown in Figure 3. Assume the termination is a 22 ohm resistor and the generator is driving a sinusoid.
 - a. What VSWR do you expect on the transmission line?
 - b. If you wanted to sweep the frequency of the input sinusoid to observe the maxima and minima of a standing wave at channel 2, what frequency would you start at and what frequency would you end at? Note this function generator maxes out at 20MHz.

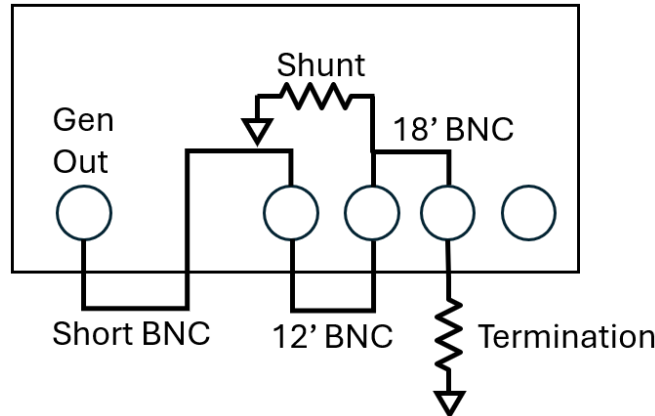

Figure 2

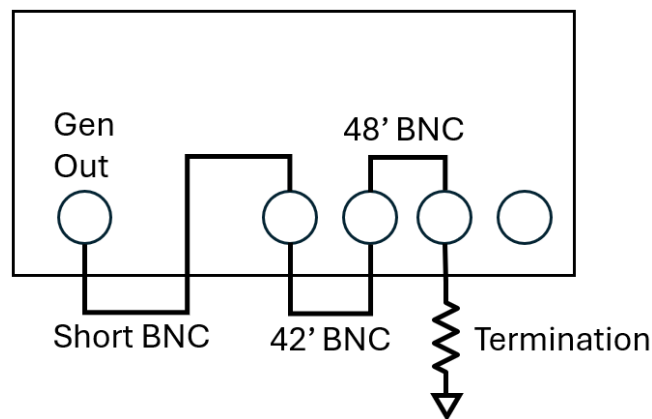

Figure 3

Lab Instructions

1. Use lossless transmission line elements to simulate the scenarios that you calculated waveforms for in the theory section. Compare your simulation and calculations.
2. Build these scenarios from the theory section in the RF lab and record measured voltages at the oscilloscope terminals. Compare your simulation, calculations and theory.
 - a. Don't forget about the "out-term" setting on function generators. It should be set to Hi-Z, and if not your measurements will appear to be off by a factor of 2.
 - b. The expectation in this class is that you can make simulations, calculations and theory match well, and that any deviations between them are quantitatively explained. (e.g.: "the virtual length of the connector is 1cm, which accounts for the extra 1cm of length extracted from the waveform" is better than "these don't match because we didn't account for electrical length of connectors.")
 - c. Achieving these quantitative descriptions may require you to perform a process called parasitic optimization, where you add parasitic elements to your simulation and adjust them until it matches your measurements. A little parasitic inductance (approx. nH) in series with grounded elements is often all you need. (This is especially important for short terminations.)

- d. You will need to include loss in your simulated transmission line models for the scenario in Figure 3. These links will help:
http://ltwiki.org/index.php?title=O_Lossy_Transmission_Line
<https://electronics.stackexchange.com/questions/323647/ltspice-how-to-model-a-tline>
- e. We have a rig to help you build out your BNC measurements, thanks E4 students! See below. This rig cleans up your measurements a lot by reducing strain on the connectors.

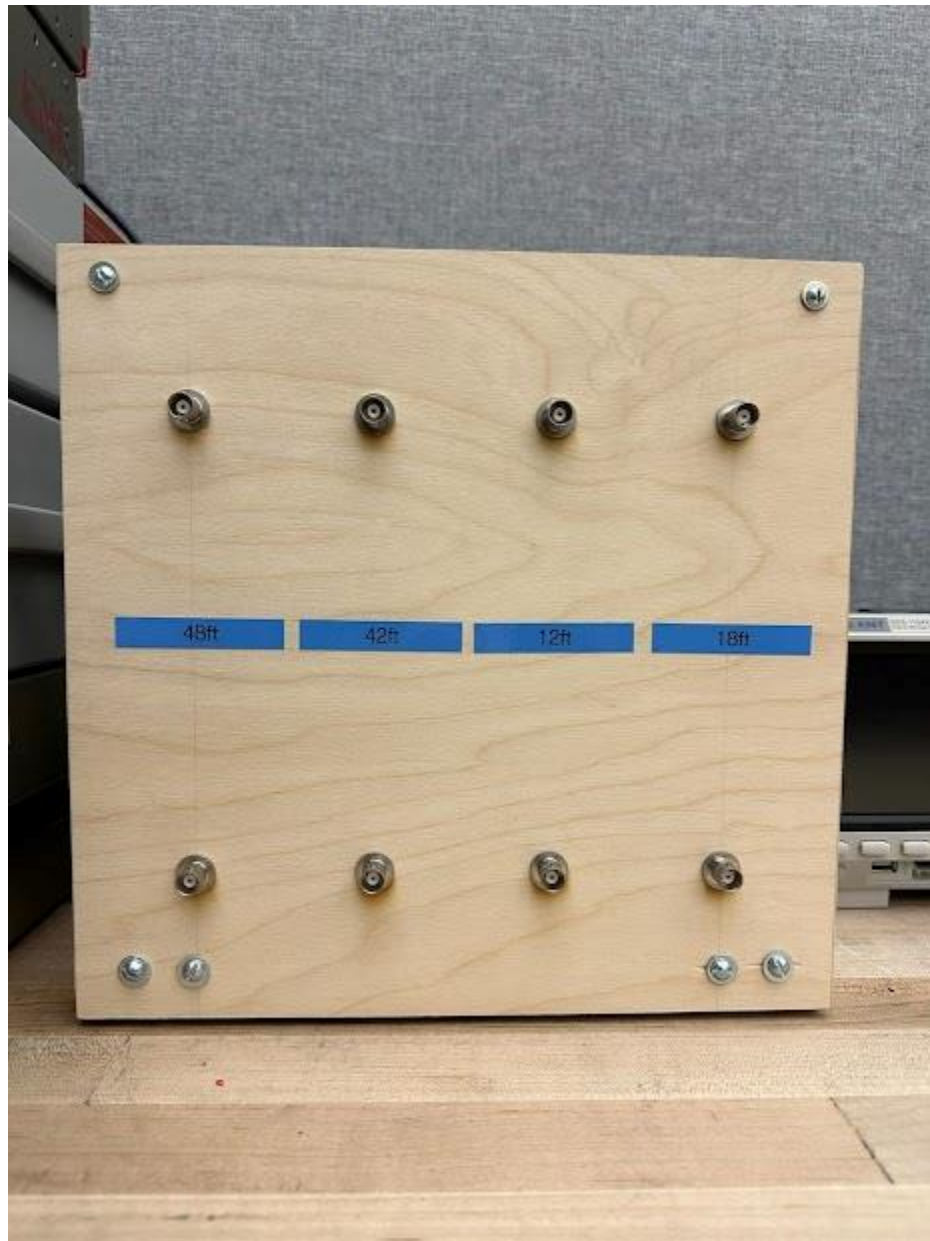

Figure 4

3. Optional extra credit: Repeat your simulations of Figure 1 using a lossy transmission line element and an appropriate model to set your series resistance to 30milliOhm/m and then 10Ohm/m. How does this series resistance affect your measured waveforms?

Required data in lab notebook: Schematics of simulations for figures 1, 2 and 3. Simulated time domain traces for each channel on figures 1, 2 and 3, and comparisons to calculated traces from theory section. Documentation on how you built your lab setup, including pictures. Time domain traces from the oscilloscope (NOT CELL PHONE PICS, EXPORT YOUR DATA) and comparison to simulated traces and theoretical calculations.