

Lecture 13: Stability

Matthew Spencer

Harvey Mudd College

E157 – Radio Frequency Circuit Design

What Causes Instability?

Matthew Spencer

Harvey Mudd College

E157 – Radio Frequency Circuit Design

In this video we're going to discuss instability, a phenomenon that plagues many amplifiers at high frequency.

Instability is Sinusoids Not Caused by Input

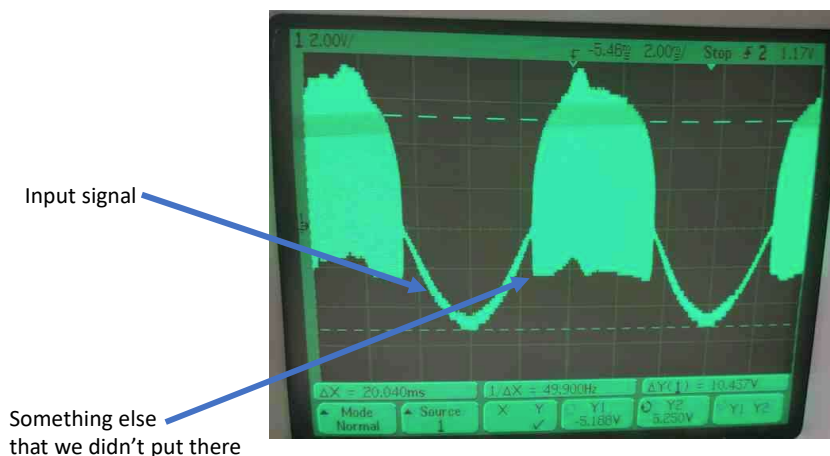

<https://electronics.stackexchange.com/questions/160289/question-about-op-amp-dc-offset>

3

And we need to start by defining what instability is. You may have run into definitions of stability like “Bounded Input Bounded Output” or BIBO in linear systems classes, but I find those definitions are insufficient to circuits. The definitions struggle because all circuits are non-linear eventually; only a precious few circuits can make voltages outside of their power rails. That means all outputs are going to be bounded regardless of input, so BIBO loses some of its charm.

Instead, I make do with a colloquial definition, which is that you know you’re seeing instability if there is frequency content in your output that you didn’t put there. Your input can create signals at the input frequency, and it can create harmonics of those signals when it’s being driven into a non-linear element, so instability will look like additional frequency content beyond those two contributions. An example of the output from an unstable circuit is pictured above, there’s an input signal with other sinusoids riding on top of it, and those sinusoids are clearly not related to the frequency of the input signal.

Students often confuse instability with coupling, noise, pickup or other signal corrupting behaviors. We will talk a bit more about noise later, but one distinguishing factor for instability is that it’s often big. If you’ve got a big problem at one frequency, it’s often instability.

Instability Comes from Feedback

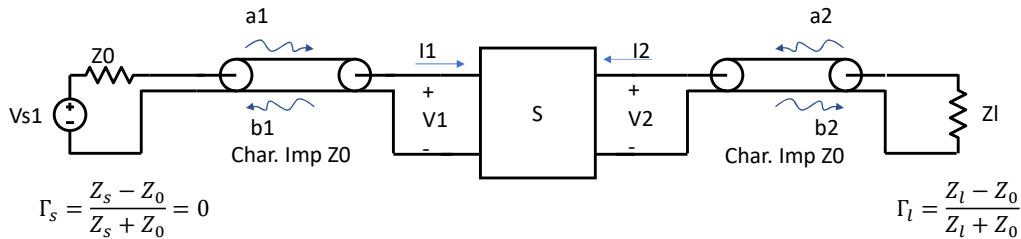

- Feedback comes from output reflections and input reflections
- Adding explicit feedback between networks → another network

Instability in circuits comes from feedback. Your circuit is unstable if a feedback loop takes a minor perturbation at some frequency and amplifies it. Two common sources of feedback in high frequency circuits are the reflections off of the load and the source. For instance, b_2 might take a round trip bouncing off of Z_l and then off of S_{22} , which means that it has the potential to contribute to its own power. So you can imagine if that round trip has a sufficiently high gain, then b_2 will get larger until something in the circuit goes wrong: clipping the output, swamping the signal with oscillations, or even blowing up the S-parameter network in extreme cases.

As an aside: It's possible to connect two port networks in feedback – imagine connecting port 2 of one network to port 1 of another, then closing the loop by hooking port 2 of the second network to port 1 of the first. That type of connection still has two ports, which we can represent with some set of S-parameters. We're going to ignore two-port feedback interconnections here because they just create some composite set of S-parameters that we can analyze in the same way as a single two-port.

Layout, Grounding and Bypassing are Crucial

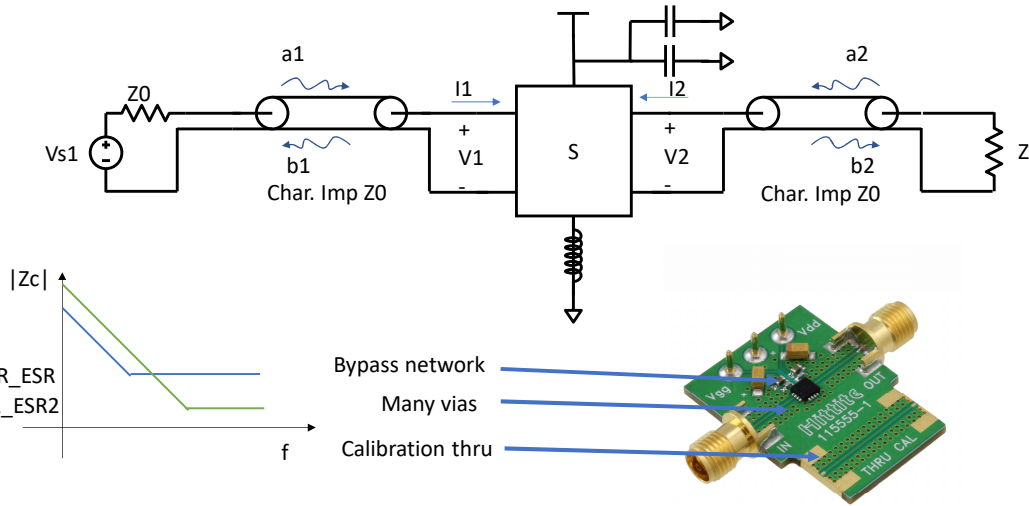

<https://electronics.stackexchange.com/questions/417594/what-is-the-purpose-of-having-a-thru-cal-on-rf-pcb?rq=1>

Though most of these videos are going to focus on modeling input and output reflections, there is another source of instability that is much more common. That source of instability is called supply coupling, and it occurs when a two-port network's connection to the power supply has high impedance. This means the power supply voltage can fluctuate during the two-port's operation, which is a parasitic and potentially unstable feedback loop.

CLICK The impedance that causes the power supply fluctuations often comes from series inductance. This can be especially prevalent when the ground is connected to the ground plane by vias with high inductance. Putting many vias in parallel can reduce the apparent inductance.

CLICK Another crucial way to keep the power supply impedance low and prevent instability is using networks of bypassing capacitors attached between the supply and ground. Bypass capacitors prevent current drawn from the supply from causing voltage fluctuations. You can think of this from an impedance point of view – the impedance seen from the supply node is low at high frequencies if many caps are in parallel. You can also think of the function of bypass caps from a physics point of view: by attaching a big pile of charge to the supply in the form of the capacitors, you have made it so the load needs to pull a lot more current in order to change the capacitor voltage.

CLICK Notice that the bypass network has many capacitors in parallel, that's because the capacitors have equivalent series resistance (and equivalent series inductance, which we

haven't talked about yet), and these parasitics prevent any individual capacitor from having a low impedance at all frequencies. However, many capacitors of different sizes can have a low impedance over a wide frequency range.

CLICK This is an example of a high frequency board, and you can see that there are many capacitors in parallel bypassing the chip's supply, and also that the ground plane is connected to the back side of the board by many parallel vias to reduce series inductance. As a side note, this board includes a calibration thru, which is a nice reminder that it's important to design for calibration. This is a well-designed board because it pays attention to these supply issues, and you need to pay attention to these details for your high frequency designs to work. Fortunately, most high frequency chips will come with layout and bypassing recommendations in their datasheets. Follow those religiously unless you know what you're doing.

Summary

- Instability looks like sinusoids in your output that are unrelated to your input.
- Instability comes from feedback
- Some feedback loops are common to all 2-ports:
 - Input and output reflections ← see next videos for solution
 - Supply coupling ← fix w/ bypass caps, parallel vias, recommended layouts

Input Reflection Coefficient

Matthew Spencer

Harvey Mudd College

E157 – Radio Frequency Circuit Design

7

In this video we're going to analyze the effect of unmatched loads on reflections off the input of a two-port network. This is an important lens for analyzing stability because the reflections off of each port of the two-port network are crucial factors in determining stability.

Unmatched Port 1 Reflections Aren't Just S11

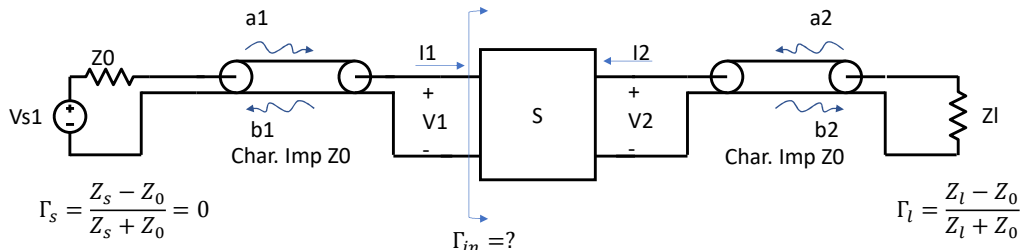

$$\Gamma_s = \frac{Z_s - Z_0}{Z_s + Z_0} = 0$$

$$\Gamma_l = \frac{Z_l - Z_0}{Z_l + Z_0}$$

$$b_2 = S_{21}a_1 + S_{22}a_2$$

$$b_1 = S_{11}a_1 + S_{12}a_2$$

$$a_2 = \Gamma_l b_2$$

$$b_1 = S_{11}a_1 + \frac{S_{12}S_{21}\Gamma_l}{1 - S_{22}\Gamma_l} a_1$$

$$b_2 = S_{21}a_1 + S_{22}\Gamma_l b_2$$

$$\Gamma_{in} = S_{11} + \frac{S_{12}S_{21}\Gamma_l}{1 - S_{22}\Gamma_l}$$

$$b_2 = \frac{S_{21}}{1 - S_{22}\Gamma_l} a_1$$

$$\Gamma_{out} = S_{22} + \frac{S_{12}S_{21}\Gamma_s}{1 - S_{11}\Gamma_s}$$

$$a_2 = \frac{\Gamma_l S_{21}}{1 - S_{22}\Gamma_l} a_1$$

I've drawn a two-port network here that has a mismatched load. That means that we need to define a reflection coefficient off the load, and we have done so in the form of Γ_l . The source is matched in this example. We're curious what a reflection off the input port looks like now that we'll see some additional power into port two from load reflections. We'll call the effective reflection coefficient Γ_{in} .

CLICK We can start by writing one of the equations that define S parameters, and observing that we need to find b_1 over a_1 . However, to find b_1 over a_1 , we'll need to eliminate a_2 from this equation.

CLICK, So we write the other equation that defines S-parameters to do that.

CLICK And we combine that definition with the fact that waves leaving port two get reflected off the load, creating a round trip

CLICK We can substitute that relationship into our equation, CLICK then rearrange it to find b_2 , CLICK then finally find a_2 by multiplying b_2 and Γ_l because a_2 is caused by b_2 reflecting off the load.

CLICK This gets substituted into our first equations, which leaves us tantalizingly close to finding Γ_{in} .

CLICK factoring out a_1 and dividing both sides by it, we find that Γ_{in} is given by S_{11} plus some additional amount that depends on the product of S_{12} , S_{21} and Γ_l . I find that product somewhat intuitive because it is the set of reflection coefficients a_1 sees to

get back to b_1 through port2.

CLICK Finally, note that we could find the reflection behavior of the opposite port by swapping S_{11} and S_{22} in the equation.

There's Another Way to Write Γ_{in}

$$\Gamma_{in} = S_{11} + \frac{S_{12}S_{21}\Gamma_l}{1 - S_{22}\Gamma_l}$$

$$\Gamma_{in} = \frac{S_{11}(1 - S_{22}\Gamma_l)}{1 - S_{22}\Gamma_l} + \frac{S_{12}S_{21}\Gamma_l}{1 - S_{22}\Gamma_l}$$

$$\Gamma_{in} = \frac{S_{11} - \Gamma_l(S_{11}S_{22} - S_{12}S_{21})}{1 - S_{22}\Gamma_l}$$

$$\Gamma_{in} = \frac{S_{11} - \Gamma_l\Delta}{1 - S_{22}\Gamma_l}$$

Determinant of S, called Δ

There's one common alternate form for Γ_{in} that we need to derive.

CLICK We can combine S_{11} with the second term by multiplying and dividing by the denominator

CLICK, then we factor out Γ_l and find that it's multiplied by an interesting S parameter quantity.

CLICK This difference of products is the derivative of the S-parameter matrix, which is often given the symbol Δ

CLICK So we can also write Γ_{in} in this form, which depends on the S matrix determinant.

Summary

- The reflection off a port in a S-parameter network depends on mismatch in the load

$$\Gamma_{in} = S_{11} + \frac{S_{12}S_{21}\Gamma_l}{1 - S_{22}\Gamma_l} = \frac{S_{11} - \Gamma_l\Delta}{1 - S_{22}\Gamma_l} \quad \leftarrow \text{Determinant of S}$$

$$\Gamma_{out} = S_{22} + \frac{S_{12}S_{21}\Gamma_s}{1 - S_{11}\Gamma_s} = \frac{S_{22} - \Gamma_s\Delta}{1 - S_{11}\Gamma_s}$$

- This is because of signals taking a round trip, a kind of feedback.

Stability Circles

Matthew Spencer

Harvey Mudd College

E157 – Radio Frequency Circuit Design

In this video we're going to create a geometric construct that indicates when a load reflection causes an S-parameter network to be unstable.

Circle in Γ -Plane Separates Un/Stable Loads

- Reflections shrink if $|\Gamma_{in}| < 1$ for all $|\Gamma_l| < 1$ (and same for Γ_{out}, Γ_s)

$$|\Gamma_{in}| = \left| \frac{S_{11} - \Gamma_l \Delta}{1 - S_{22} \Gamma_l} \right| < 1$$

↓ Algebra so bad it's not in textbooks

$$\left| \Gamma_l - \underbrace{\frac{S_{22}^* - \Delta^* S_{11}}{|S_{22}|^2 - |\Delta|^2}}_{C_{\Gamma_l}} \right| > \underbrace{\frac{|S_{12} S_{21}|}{|S_{22}|^2 - |\Delta|^2}}_{R_{\Gamma_l}}$$

Swap S11 and S22 to find Γ_s circle

To do that, we first notice that we'll have a stable network if the magnitude of Γ_{in} is less than 1 for all loads where the magnitude of Γ_l is less than 1. Γ_{in} being less than 1 guarantees that reflections off the port are smaller than when they started, which means the signal will eventually die out. The constraint that Γ_l be less than 1 is part of the guarantee that the signal will die out because Γ_l is part of the round trip that a signal takes, but it is also a sensible constraint because the problem with instability is in the load if the magnitude of Γ_l is greater than one.

CLICK We can put that constraint into math using this expression

CLICK And fortunately for you, the derivation of showing how that constraint gets turned into this form is so miserable that even textbooks skip it. I've linked a derivation on the course website, but we are just going to assume we can get from the expression at the top of the page to the expression here.

CLICK We define two quantities in this equation as C_{Γ_l} and R_{Γ_l} . Those letters aren't chosen frivolously: this equation defines a circle of possible load reflection coefficients, and the center will be at C_{Γ_l} and radius R_{Γ_l} . Because we started with a stability criteria, this circle defines the dividing line between stable and unstable loads. That's super useful! If we draw this circle on the Smith Chart, we'll be able to tell what load impedances are safe and what load impedances will cause oscillations. This circle is referred to as a stability circle.

CLICK Finally, note that we can find another stability circle by starting with Γ_{out} , and that circle will tell us what source impedances cause instability.

Picture of Stable / Unstable Load/Src Regions

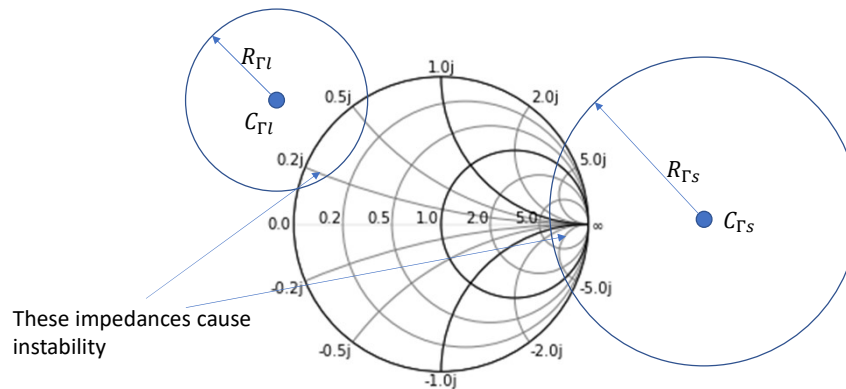

13

So this is a graphical representation of a stability circle overlaid on a Smith Chart. C_{Γ_L} isn't necessarily located inside of the unit circle described by the Smith Chart, and that's shown in this case. R_{Γ_L} in this example allows for a region of overlap between the Smith Chart and the stability circle. CLICK that means that these impedances are unstable because we defined the region outside the stability circle as being stable. CLICK We can also add a second circle to represent the source reflections, and that will define a second set of impedances that are unsafe source impedances for the two port.

Summary

- We achieve stability if reflections get smaller, i.e.: $|\Gamma| < 1$.
- The Γ_{in} (or Γ_{out}) equation defines a circular region of load impedances (or source impedances) that cause instability with center C and radius R

$$\left| \Gamma_l - \underbrace{\frac{S_{22}^* - \Delta^* S_{11}}{|S_{22}|^2 - |\Delta|^2}}_{C_{\Gamma_l}} \right| > \underbrace{\frac{|S_{12} S_{21}|}{|S_{22}|^2 - |\Delta|^2}}_{R_{\Gamma_l}}$$

Swap S11 and S22 to find Γ_s circle

Unconditional Stability

Matthew Spencer

Harvey Mudd College

E157 – Radio Frequency Circuit Design

In this video we're going to look at figures of merit of two-ports that can determine if they are unconditionally stable for any load they drive.

Stable if Stability Circle Outside Unit Circle

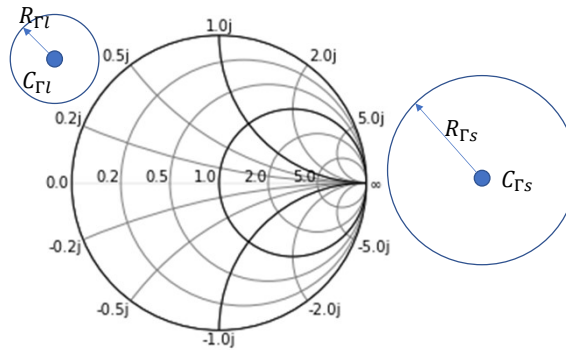

- Any load ($w/ |\Gamma| < 1$) is safe if stability circles don't overlap Smith.

Since we know the regions inside stability circles are unstable, one easy way to guarantee stability is to ensure that the stability circles don't overlap the unit circle. So the system pictured here is unconditionally stable for any load because the load can't possibly fall inside a stability circle.

Stability Circle not Touching Unit Circle Math

$$\left| \Gamma_l - \underbrace{\frac{S_{22}^* - \Delta^* S_{11}}{|S_{22}|^2 - |\Delta|^2}}_{C_{\Gamma l}} \right| > \underbrace{\frac{|S_{12} S_{21}|}{|S_{22}|^2 - |\Delta|^2}}_{R_{\Gamma l}}$$

$$|C_{\Gamma l}| - R_{\Gamma l} > 1$$

Constraining stability outside unit

$$\frac{|S_{22}^* - \Delta^* S_{11}| - |S_{12} S_{21}|}{|S_{22}|^2 - |\Delta|^2} > 1$$

Sub in values of R and C

$$\frac{1 - |S_{11}|^2 - |S_{22}|^2 + |\Delta|^2}{2|S_{21} S_{12}|} > 1$$

Evil algebra assuming $|\Delta| < 1$

Called Rollett Stability Factor, or K

Could swap S11 and S22, general property of 2 port

We can return to our definition of stability circles to come up with a mathematical expression that describes the picture on the previous page.

CLICK First we want to introduce a constraint that guarantees our stability circle is outside the unit circle. Here we're just asking if the radius is long enough to extend from the center of the circle back to one. We take the magnitude of the center because that tells us its distance away from the origin.

CLICK This can be rewritten by substituting in the definitions of $C_{\Gamma l}$ and $R_{\Gamma l}$

CLICK Then we wind up with an interesting expression by invoking the terrible algebra arrow again. The math for this transformation spans two pages, which aren't very important or interesting, except that we crucially assume the magnitude of Delta is less than one when we do the derivation. Don't forget that when we're using this stability technique the magnitude of Delta has to be less than 1.

CLICK This expression is called the Rollett stability factor, and given the symbol K. When K is greater than 1, we know that we're unconditionally stable. That's awesome, and it's even more awesome because this expression is symmetric. We could swap S11 and S22 in order to get the same result, which means we summarize the stability of both ports 1 and 2 in one number.

Unilateral Stability Easy to Calculate

$$\left| \Gamma_l - \underbrace{\frac{S_{22}^* - \Delta^* S_{11}}{|S_{22}|^2 - |\Delta|^2}}_{C_{\Gamma_l}} \right| > \underbrace{\frac{|S_{12} S_{21}|}{|S_{22}|^2 - |\Delta|^2}}_{R_{\Gamma_l}} \quad \text{Swap } S_{11} \text{ and } S_{22} \text{ to find } \Gamma_s \text{ circle}$$

If $S_{12}=0$ because the system is unilateral:

$$R_{\Gamma_l, \text{Unilateral}} = 0$$

$$C_{\Gamma_l, \text{Unilateral}} = \frac{S_{22}^* - S_{11}^* S_{22}^* S_{11}}{|S_{22}|^2 - |S_{11} S_{22}|^2} = \frac{S_{22}^* (1 - S_{11}^* S_{11})}{|S_{22}|^2 (1 - |S_{11}|^2)} = \frac{1}{S_{22}}$$

Unsurprisingly, unilateral networks are easy to figure out. The radius of a unilateral stability circle simplifies to zero, and the center turns into $1/S_{22}$. That means we're stable as long as the magnitude of S_{11} and S_{22} are less than 1. This makes sense because Γ_{in} reduces to S_{11} for unilateral networks: there's no chance for an a_2 wave to sneak back to the input and change the behavior of the b_1 wave.

Another Stability Idea: Keep Γ_{in} in Unit Circle

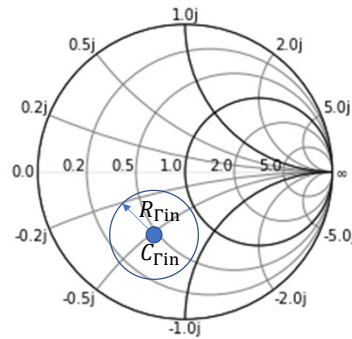

- Consider circle of Γ_{in} defined by varying Γ_l . Stable if all in unit circle.

There's one other stability criterion that's worth examining called the geometric or Edwards-Sinsky stability factor. This is actually rather new technology compared to the Rollett stability factor, these stability factors were only invented in 1992, while Rollett dates back to the 1950s.

The main idea is that we can define a circle around Γ_{in} that shows what values it can assume as Γ_l is varied. If that circle never leaves the unit circle, then we're unconditionally stable.

Find Stability By Finding Γ_{in} with Worst Load

$$\Gamma_{in} = \frac{S_{11} - \Delta e^{j\phi}}{1 - S_{22} e^{j\phi}}$$

Γ_{in} in unit circle w/ worst case load: $\Gamma_l = 1 \cdot e^{j\phi}$

$$\left| \Gamma_{in} + \frac{S_{11}^* \Delta - S_{22}}{1 - S_{22}} \right| = \frac{|S_{12} S_{21}|}{|1 - S_{22}|}$$

$$|C_{\Gamma_{in}}| + R_{\Gamma_{in}} < 1$$

Same terrible algebra as stability circles

Constrain Γ_{in} circle inside the unit circle

$$\left| \frac{S_{11}^* \Delta - S_{22}}{1 - S_{22}} - \frac{|S_{12} S_{21}|}{1 - S_{22}} \right| < 1$$

Sub in $C_{\Gamma_{in}}$ and $R_{\Gamma_{in}}$

Normal algebra

$$\frac{1 - |S_{11}|^2}{|S_{11}^* \Delta - S_{22}| + |S_{12} S_{21}|} > 1$$

Input Geometric Stability Factor, or μ_1 ,

- sufficient for stability even though μ_2 exists
- Nice properties: value indicates relative stability

We've started finding a mathematical summary of this criterion by rewriting the Γ_{in} expression with a worst case value of Γ_l , a perfectly reflective load with magnitude of 1 and angle of ϕ .

CLICK We invoke the same terrible algebra we used to make stability circles to convert the Γ_{in} equation into a circle. Note that we lost all the $e^{j\phi}$ values in this step, and that's because we took the magnitude of most of these expressions.

CLICK We know that our criterion is satisfied if the center plus the radius of this Γ_{in} circle is smaller than the radius of the unit circle.

CLICK So we sub in our values from the expression just above

CLICK and then do some relatively tame algebra that, nonetheless, doesn't fit on this slide, and wind up with another stability factor. This is called the input geometric stability factor, and we call it μ_1 . We can also find a μ_2 by looking at the output port, but it turns out either μ_1 or μ_2 being larger than 1 guarantees stability. The really nice property of this stability factor is that it indicates relative stability: higher values of μ correspond to more stable systems. So, for instance, you could compare μ_1 and μ_2 in order to determine if your input or output was at greater danger of causing instability. That's handy, and you can't do that with the Rollett stability factor.

Summary

- Unconditional stability comes from stability circles outside unit circle

$$K = \frac{1 - |S_{11}|^2 - |S_{22}|^2 + |\Delta|^2}{2|S_{21}S_{12}|} > 1 \quad \text{Rollett}$$

- OR from Γ_{in} (or Γ_{out}) never leaving the unit circle

$$\mu_1 = \frac{1 - |S_{11}|^2}{|S_{11}^* \Delta - S_{22}| + |S_{12}S_{21}|} > 1 \quad \text{Geometric or Edwards-Sinsky}$$