

# Lecture 11: Measuring S Parameters

Matthew Spencer

Harvey Mudd College

E157 – Radio Frequency Circuit Design

# Fixturing and The Reference Plane

Matthew Spencer

Harvey Mudd College

E157 – Radio Frequency Circuit Design

2

In this video we're going to talk about practical considerations for measuring S parameters that arise from the wires used to measure a device under test, or DUT.

# S Parameters of Lossless Transmission Line

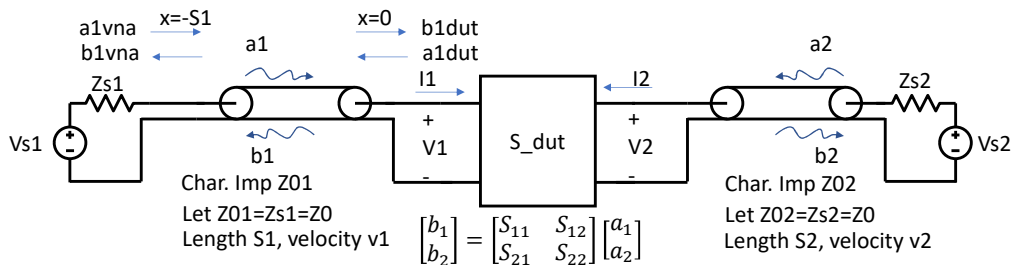

$$b_{1dut} = a_{1vna} \exp(-jkS_1)$$

$$S_{matched\_tline} = \begin{bmatrix} 0 & \exp(-jkS) \\ \exp(-jkS) & 0 \end{bmatrix}$$

$$S_{vna} = \exp(j(k_1S_1 + k_2S_2)) S_{dut}$$

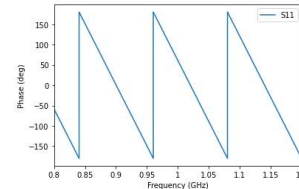

Our setup is that we need to measure some device under test, and we have some fancy instrument to do so that lets us control  $V_{s1}$ ,  $V_{s2}$ ,  $Z_{s1}$ , and  $Z_{s2}$ . However, we're in a tough spot because we're stuck measuring the S parameters of a combined system: our DUT plus the wires we used to connect it to our instrument. These wires, along with all the adapters and connectors that are attached to them, are referred to as fixturing.

CLICK If we care about these wires, then we need to define a few more properties for them, so we assign lengths  $S_1$  and  $S_2$  and velocities  $v_1$  and  $v_2$  to them. Our instrument won't know these properties in advance, so we're going to have to figure out how they affect our measurement. CLICK I'm also going to remind you that we define  $x=0$  at the DUT and  $x=-S_1$  at the test instrument.

CLICK Each wire is going to have some S parameters, and if we find those, then maybe we can cancel them out of the measurement of the DUT. So we've define a set of incident and reflected waves on one of the transmission lines attached to the DUT. The subscript VNA stands for vector network analyzer, which is the name of the fancy instrument that I mentioned earlier.

CLICK Transmission lines just add a little bit of delay to our signals, which I've represented for one pair of signals in this equation. CLICK if you extend this to all the signals, you find

that the S parameters of a transmission line just look like a pair of delays in the off-diagonal locations. CLICK You can rearrange the S-parameters of transmission lines to find the measured S parameters at the VNA in terms of the S parameters of the DUT, and it looks like a simple addition of phase to the DUT parameters.

CLICK This is pretty bad news. It means the S-parameters we measure will have an evolving phase on top of the behavior of the DUT, which I've pictured here. It's often difficult to back DUT phase behavior out of the phase of the fixturing, so we need to find a way to remove the effect of the cables. Fortunately, the math is simple: if we can find the value of  $kS$ , then we can cancel out the extra phase we've picked up from the transmission line. Don't forget that  $S_1$  and  $S_2$  are defined as negative numbers, so we should add positive phase to cancel out the delay of the transmission lines.

# You Can Use Standing Waves to Find Delay

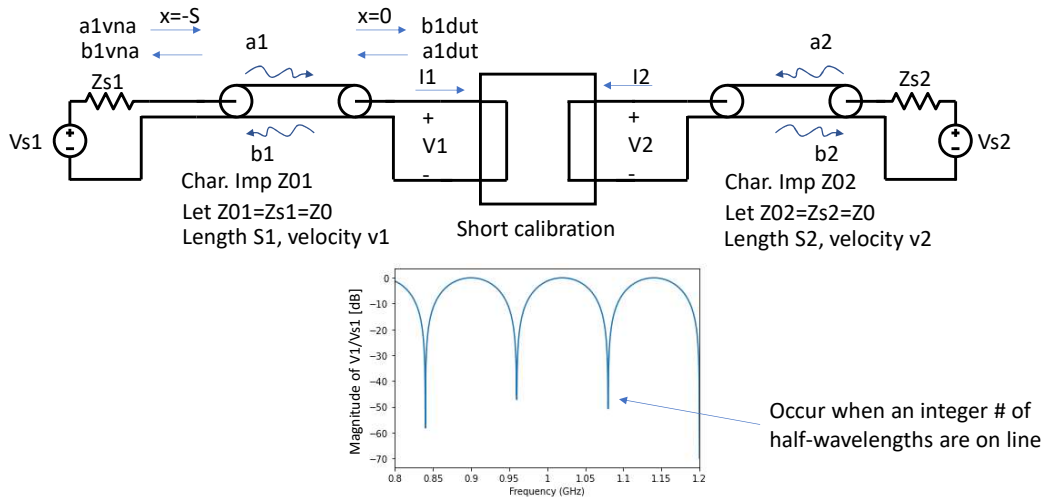

Fortunately, we can attach shorts to each wire to find the value of  $kS$ , a process that is called a short calibration. One algorithm for doing so, which was originally developed in the days of the slotted line, relies on easy-to-measure nulls in the standing wave pattern. By varying the drive frequency of  $V_{s1}$  and  $V_{s2}$ , we can change  $k$ , which in turn changes the number of periods of the standing wave pattern that are standing on the transmission line. Whenever there's a null in the voltage at  $V_{s1}$ , we know that an integer number of half-wavelengths are on the line because we're effectively seeing a short as our driving point impedance. Using that fact, if we know the frequency of two adjacent nulls then we can find  $kS$  as a function of the frequency. That requires a few algebraic manipulations of the wave number, but I'll leave the process to the viewer to work out.

Phase is always measured relative to some reference signal, so when we cancel out the phase introduced by the fixturing, we're effectively saying that we consider  $x=0$  as the point where our signal has zero phase. The point where your signal has zero phase is called the reference plane. By calibrating our system we've effectively moved the reference plane from  $x=-S$  to  $x=0$ .

## Fixturing Often has a Frequency Response

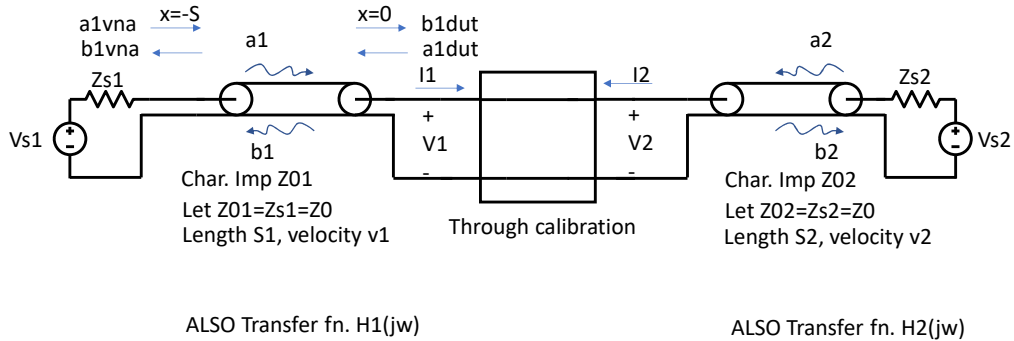

- Measure  $H_1(j\omega) \cdot H_2(j\omega)$  by hooking fixturing cables together.

The fixturing also usually has a frequency response due to attenuation and resonance in imperfectly matched connectors. However, you can cancel out the frequency response of fixturing by connecting the two wires attached to ports 1 and 2 directly to one another, which is called a through calibration. The VNA can measure the combined frequency response of the two wires and store that information to cancel it out later. Note that this type of calibration is very specific to the wires and connectors that you're using.

## Summary

- Wires connected to a device under test (or DUT) are called fixturing.
- Fixturing adds delay, which looks like a linear increase in phase w/  $\omega$ , we calibrate it out (move the reference plane) with a short calibration
- Fixturing has a frequency response, and we calibrate it out with a through calibration.
- Vector network analyzers measure S parameters, store calibration

# Directional Couplers

Matthew Spencer

Harvey Mudd College

E157 – Radio Frequency Circuit Design

In this video we're going to learn about an important circuit called a directional coupler that's at the heart of vector network analyzers.



## Directional Couplers Split Fwd/Rev Waves

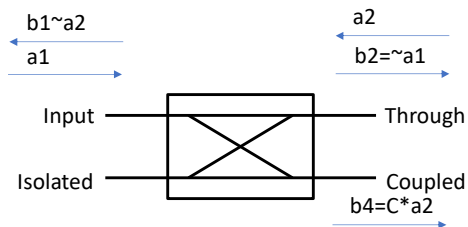

- 4 ports all matched to  $Z_0$ , but isolated port doesn't do much.
- Through and input  $\sim$ same, but waves incident on through  $\rightarrow$  coupled.

8

Directional couplers are matched 4 port networks, and the four ports are named Input, Through, Isolated and Coupled. The Isolated port isn't used much: it is usually just used to sink power. That might seem wasteful, but it turns out that 3 port networks can't be simultaneously matched, reciprocal and lossless because of some vagaries of matrix math, so we need that port for this device to work well.

The first function of the directional coupler is already illustrated on this slide. A wave incident on the input port will appear almost in full on the through port. That's not much more interesting than transmission lines, but if we have a wave incident on the through port, then something interesting happens. Most of the signal from the through port appears on the input port, but some fraction of the  $a_2$  wave appears on the coupled port. The coupling coefficient, or  $C$ , sets the fraction of the  $a_2$  wave that gets coupled.

## Build this with Transformers, Fancy EM Tricks

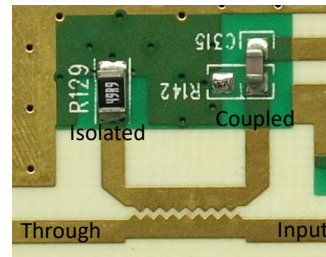
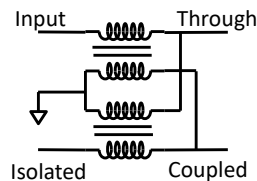

- Values of  $C$ , relative phase (often  $\pm 180$ ) are designable.
- Part of a class of circuits called Hybrid Couplers, cousin to splitters

That's weird behavior! And it takes accordingly weird circuits to accomplish it. At low frequencies, up to about 600 MHz, we can add and subtract voltages and currents using a pair of cross-coupled transformers to create voltages that are proportional to wave amplitude on the coupled and isolated ports. We create these voltages by making the transformers mimic the equations for wave amplitude, which we derived in a previous video. However, transformers are hard to build at high frequencies, so we need to rely on some tricky electromagnetic effects instead. In the directional coupler shown here, a voltage wave from the input to the through will result in some field lines landing on the wire between the isolated and coupled ports. That forces a reverse travelling wave to emerge on isolated-to-coupled wire in order to cancel out the wave induced by the forward travelling input-to-through wave.

These couplers can be designed for different coupling coefficients and relative phases on the ports. Also, its possible to make some interesting behaviors by swapping around what port is used the input. For example, if you set coupling coefficient to one half and drive an input on the through port, then half of that signal would come out on each of the input and coupled ports. Said another way: the through signal gets evenly split between two other ports, while keeping all the ports matched. A circuit that does that splitting is called a splitter, and many splitters and directional couplers are part of a broader class of circuits called hybrid couplers.

## Finite Directivity → Input on Coupled Port

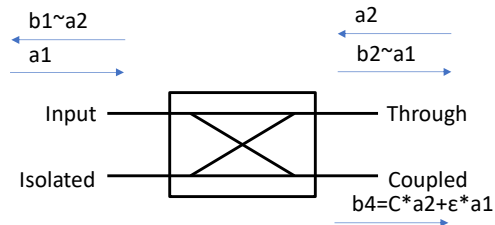

- Common non-ideality, directly affects VNA measurements.

Finally, we need to discuss an important parasitic in directional couplers. Directional couplers aren't perfect devices, so they can leak signals between their ports. Directivity, which we give the symbol  $\epsilon$ , refers to how much of the signal on the input port appears on the coupled port. In a perfect world  $\epsilon$  is zero, but in the real world, some of the input signal appears directly on the coupled port. This can swamp out the signal coupled from  $a_2$  if  $a_1$  is a large signal.

## Summary

- Directional couplers send input signals to the through port and through signals to the coupled port.
- Finite directivity lets some input signal onto the coupled port.
- You can make directional couplers with transformers or t lines.

# Vector Network Analyzer

Matthew Spencer

Harvey Mudd College

E157 – Radio Frequency Circuit Design

In this video we're going to discuss the operation of a vector network analyzer.

## Directional Couplers Pick Fwd/Rev Waves

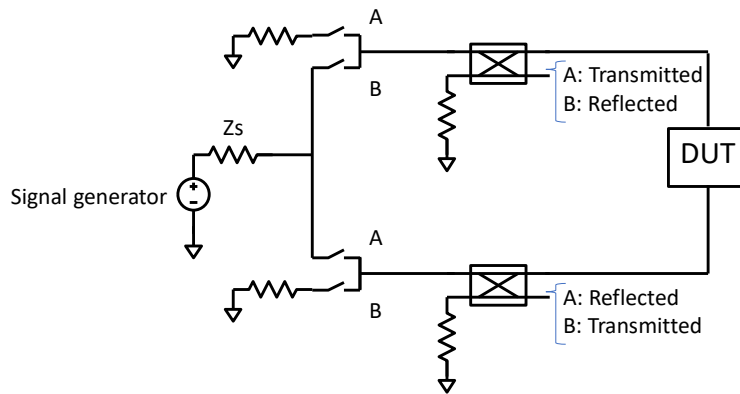

- Either both A switches or both B switches are on at one time.

This picture shows a simplified vector network analyzer. It features a signal source, a pair of directional couplers and a few termination resistors that are matched to the system impedance. Two sets of switches are turned on and off in sync to configure the behavior of the system. If the A switches are on, then the generator signal will propagate forward through the lower directional coupler. The generator signal will interact with our two-port DUT generating a transmitted and a reflected wave, and those waves will each hit a directional coupler, resulting in scaled versions of the transmitted and reflected signals appearing on the coupled ports of both the top and bottom directional couplers respectively. Flipping the switches to the B configuration will run a signal through the upper directional coupler, that will also result in transmitted and reflected signals appearing on the directional couplers, but those signals will be a result of the other half of the S-parameter matrix. Comparing the coupled signals to the amplitude to the incident wave allows you to calculate each of the four S parameters.

## Source Mismatch: $Z_s \neq Z_0$ , Leads to Errors

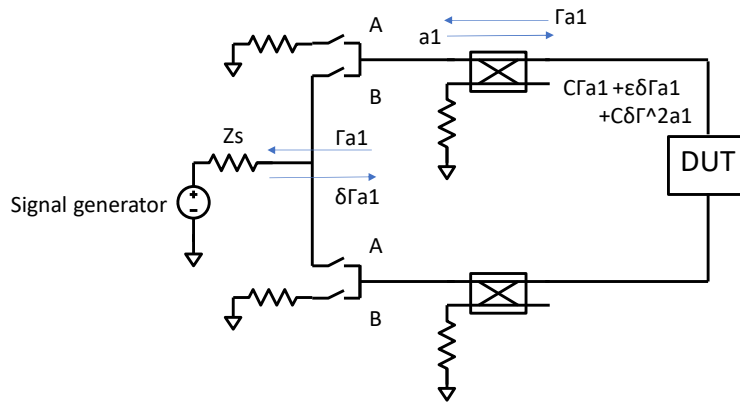

- This is a second source of error that combines with finite directivity

The components in the VNA can introduce errors into the VNA's measurements. We've already talked about how directivity in the directional couplers could be an issue, so I've left it off this slide for now, but we're going to discuss another potential issue called source mismatch.

CLICK this incident wave  $a_1$  will have some reflection off the DUT, and that signal will go back from the through port to the input port. That's fine, we expect that the signal will be terminated by  $Z_s$ , which we assume is matched to  $Z_0$ . CLICK However, if there is some mismatch, then some signal will get reflected back towards the directional coupler. We use the symbol  $\delta$  to represent the fraction that gets reflected as a result of this source mismatch. CLICK The reflected mismatch signal passes through the directional coupler, creating an error as a result of finite directivity. CLICK The reflected mismatch signal also passes to the through port, and then gets reflected off of the DUT and coupled out as well. There are other terms from additional reflections off the source port, but we're going to neglect them by assuming  $\delta^2$  is small.

Source mismatch matters most when the DUT is highly reflective, so that  $\Gamma$  is close to one.

## Summary

- Vector network analyzers use directional couplers to measure transmitted and reflected waves.
- VNAs switch between driving and terminating ports to measure all S-parameters
- Source mismatch adds directly to error, especially if  $\Gamma$  is high.



# VNA Calibration

Matthew Spencer

Harvey Mudd College

E157 – Radio Frequency Circuit Design

In this video we're going to discuss calibration methods for VNAs that fix the measurement errors we've discussed in previous videos. The fact that VNAs can be precisely calibrated is one of the most important features of the device, and good calibrations enables the RF measurements necessary to make sensitive receivers. Those receivers power applications from cell phones to satellites, so these calibrations are at the heart of much of the modern world.

## SOLT is Common Calibration for Cables



- Short: fixturing delay
- Through: fixturing  $H(j\omega)$
- Open: source mismatch & similar
- Load: directivity
- Collectively: SOLT calibration



- ECal automates,

<https://www.mariohellmich.de/projects/sma-cal-kit/sma-cal-kit.html>  
<https://www.nscainc.com/new-n443xd-microwave-4-port-ecal-modules/>

17

The most common kind of calibration is called a short-open-load-through, or SOLT, calibration. Each of the SOLT calibration standards deals one of the issues that we've identified in the last few videos. As detailed previously, shorts let us correct for the delay of fixturing and throughs let us correct for the frequency response of fixturing. The remaining errors inside the VNA are all linear, so we only need two more measurements in order to calibrate them out. By convention, we choose an open circuit and a termination that matches the characteristic impedance of the system. We use the open first to calibrate out things that depend on high reflectivity like source mismatch, then we use a load to observe the remaining signal error when there is little to no reflection.

Often you'll achieve this calibration by screwing manual calibration standards onto your cabling, and I've included a picture of some of those calibration standards. However, there are instruments called ecal (which is short for electronic calibration), that automate the process by letting the VNA control switches between internal standards. They save a lot of time, but they are expensive and offer you the opportunity to destroy many standards and RF switches in one fell swoop if you are careless when using them. Even worse, when they fail they often fail silently, corrupting data rather than ceasing to work. So be careful with your ecal!

## On-Board/Chip Cals Move Ref. Plane Closer

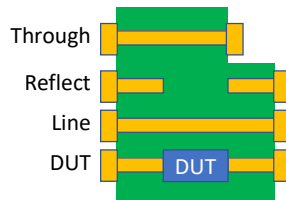

- Through-Reflect-Line (TRL) and Line-Reflect-Match (LRM) Calibration
- Port extension is another option in many VNAs.

Calibration has the effect of moving the reference plane, so a SOLT calibration with the standards on the previous page will result in a reference plane at the end of your cables. However, devices on printed circuit boards will often have some microstrip transmission lines between the connectors and the device under test. That can be fixed: you can use other calibration techniques and carefully built test structures to move your reference plane onto a PCB or even an integrated circuit. For example, I've included a picture of a common set of calibration standards for devices on printed circuit boards. These are called through-reflect-line or TRL standards. As you can see from the Through and Line standards, this calibration relies on two through measurements of transmission lines with slightly different lengths. Line-reflect-match (or LRM) standards are popular for integrated circuits, but they rely on an expensive broadband match to operate correctly.

If you don't have access to on-board calibration structures, you can compensate for a misplaced reference plane by using the Port extension feature included with many modern VNAs. The port extension feature lets you specify a distance that you'd like to adjust the reference plane, and the VNA uses the existing calibration to add more phase to your measurement. This presumes that the additional line that you virtually add to your port looks like the transmission line you used for calibration, which isn't a great assumption when transitioning onto microstrip, so calibrate in hardware as much as possible.

## Practical Considerations Affect Calibration

- Calibration is specific to cables
- Cables are easy to break, and be especially careful of bad center pins
- Mechanical connections must be controlled, so use a torque wrench.
- Minimize disconnecting and reconnecting a system.
- Calibration is specific to a frequency range, we can achieve ~500MHz
- Let the VNA warm up, temperature changes can affect calibration accuracy.

19

These are clever calibration methods, but they only work if we're mindful when we use them, because it's possible to introduce errors into your measurement that's swamp out your careful calibration. I'm going to list a few here.

CLICK The delay and frequency response of your fixturing depend on the specific cables used during calibration, so you need to recalibrate if you change cables.

CLICK That's a potential problem, because RF cables are fragile. Cables are sensitive to minor changes in characteristic impedance, so it's important not to bend them sharply and to relieve strain as often as possible. Metallic or rigid cables are tempting to reduce these cabling issues, but it's hard to prototype with them. Even worse, some cheap RF cables will have malformed center pins that damage other cables or ports they are plugged into. One bad cable can poison the data in a whole lab, so be mindful of your cables and don't be shy about paying for them.

CLICK VNAs are sensitive enough that the mechanical connection between cables will appear in your results. So use torque wrenches on every connection you make to ensure that they are all identical. This also minimizes damage to cables and connectors, which can be harmed by overtightening.

CLICK On that note, plugging and unplugging a connection can disturb a calibration, so minimize it.

CLICK Calibrations are only valid over the frequency range you used when calibrating, so be

careful about zooming in and out on your data. A closer look will require recalibration. We haven't had great luck doing very wide bandwidth calibrations in our lab, so keep in mind that we can calibrate ranges of 500MHz and smaller pretty reliably.

CLICK Finally, the components in the VNA are sensitive to temperature, so you need to let the VNA operate for a while before calibrating it. Often you need a full half hour of warmup time before a VNA calibration will be stable, so take your time after powering it up.

## Summary

- Short-open-load-through calibration is common for cabling.
- You can move the reference plane closer to the DUT with on-board or on-chip standards and other calibration techniques.
- Be mindful of practical considerations!