

Lecture 03: Loss, Impedance and Reflection

Matthew Spencer
Harvey Mudd College

E157 – Radio Frequency Circuit Design

Loss, Attenuation, Dispersion

Matthew Spencer

Harvey Mudd College

E157 – Radio Frequency Circuit Design

In this video we're going to briefly revisit the full Telegrapher's equation to examine how lossy transmission lines differ from lossless lines.

Loss in Telegrapher Causes Pulses to Shrink

$$\frac{d^2V(x,t)}{dx^2} = rgV(x,t) + \underbrace{(rc + gl)}_{\text{"Dissipation Term"}} \frac{dV(x,t)}{dt} + lc \frac{d^2V(x,t)}{dt^2}$$

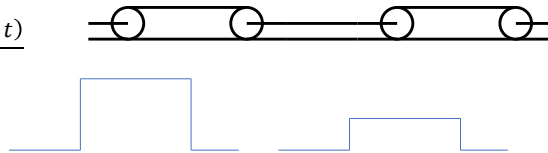

- This is called attenuation.
- The “missing” voltage is turned to heat in the r and g elements.
- Derivation later (w/ sine waves), but $V(x,t) = \exp(-\alpha t)V(x-vt,0)$

I’ve included the full Telegrapher’s equation on this slide, and I’ve highlighted a term called the dissipation term. Solving tricky partial differential equations is outside the scope of this class, so you either have to take my word that this term causes dissipation, or read the article I’ve linked on the course site.

The effect of this term is a behavior called attenuation, where energy in a moving wave gets turned to heat in the transmission line’s lossy elements. This results in a smaller version of the wave driven into the transmission line, which I’ve illustrated on the right: the wave at the middle node is a tiny replica of the wave that was driven into the left node.

We can be more specific about how small an attenuated wave becomes. We’ll do a full derivation later, but it turns out that attenuation introduces an exponential scaling factor to the shape of the wave that makes it smaller and smaller as the wave propagates further.

Loss in Telegrapher Causes Pulses to Spread

$$\frac{d^2V(x,t)}{dx^2} = rgV(x,t) + (rc + gl)\frac{dV(x,t)}{dt} + lc\frac{d^2V(x,t)}{dt^2}$$

“Dispersion Term”

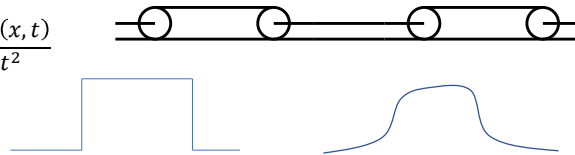

- This is called dispersion, comes from ω dependent velocities
- No dispersion if $rc = gl$, which is called the Heaviside Condition
- ~No dispersion if r and g small, which is called the low-loss condition

The last remaining term in the Telegrapher's equation is referred to as the dispersion term. It causes waves to smear out, like the pulse shown at the middle node of the transmission line on the right. This happens because waves of different frequencies move at different velocities in a dispersive transmission line. In this example, we know by Fourier that a square pulse is made of an infinite sum of sine waves, and the dispersed pulse represents the fast sine waves running ahead of the slow ones.

Dispersion is tough to analyze by hand, so we are going to focus on a few conditions that effectively eliminate dispersion. One condition that eliminates dispersion is when $rc=gl$, and this is called the Heaviside condition. Another condition that eliminates dispersion is when r is much smaller $j\omega l$ and g is much smaller than $j\omega c$, which is called the low-loss condition. We'll take a closer look at these conditions when we drive sine waves onto the transmission line.

Summary

- Loss causes pulses to shrink exponentially, which is called attenuation
- Loss causes pulses to spread out, which is called dispersion
- We can cancel dispersion with certain combinations of t line parameters, which we called the Heaviside and Low-loss condition.
- More on all of this later

Characteristic Impedance

Matthew Spencer

Harvey Mudd College

E157 – Radio Frequency Circuit Design

In this video we're going to try to figure out the relationship between voltage and current in a transmission line.

We find Current in T Lines with Differential Z

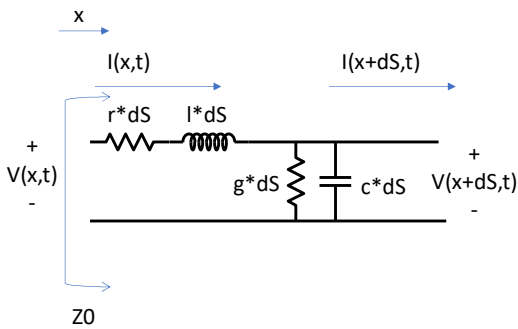

$$Z_0 = (r + j\omega l)dS + \frac{1}{(g + j\omega c)dS} \parallel Z_0$$

$$Z_0 = (r + j\omega l)dS + \frac{1}{(g + j\omega c)dS + 1/Z_0}$$

$$Z_0(g + j\omega c)dS + 1 = (r + j\omega l)dS \left((g + j\omega c)dS + \frac{1}{Z_0} \right) + 1$$

$$Z_0(g + j\omega c)dS = (r + j\omega l)dS/Z_0$$

$$Z_0 = \pm \sqrt{\frac{r + j\omega l}{g + j\omega c}} \quad \leftarrow \text{Characteristic impedance! (}/\pm \text{ for fwd/reverse wave solutions)}$$

$$Z_0 = \pm \sqrt{l/c} \quad \leftarrow \text{Lossless characteristic impedance! (a constant)}$$

We need to think about this because the telegrapher's equation solutions tell us the voltage on the transmission line, but not the current. We'd like to be able to find the current anywhere on the line too.

Fortunately, we have an easy tool to do that because each differential segment of a transmission line has some impedance. If we find this differential impedance, then we can just divide $V(x,t)$ by it to get $I(x,t)$. We give this differential impedance a special name, the characteristic impedance, and we give it the symbol Z_0 . You might notice that we've opted to use a capital Z, which suggests that this has units of impedance, not impedance per unit length.

As a side note, we're assuming constant values of r , l , g and c across the transmission line in this derivation. That's a safe assumption for most modern transmission lines, but some people violate that assumption on purpose to build microwave devices. It's also a property that sets transmission lines apart from random wires on a breadboard.

OK, to get started I've included an expression for the impedance seen by $V(x,t)$ up here. You can see that it is the sum of the impedance of the series elements and some complicated shunt element. The shunt element is made of two parts.

The first part describes the effect of the capacitance and conductance. This equation opts to represent the impedances of the conductor and capacitor as one over their admittance. Admittance is $1/\text{impedance}$, so it's like a complex version of conductance just like impedance is a complex version of resistance. The admittance of a conductor is just g , the admittance of a capacitor is one over the impedance, so it's $j\omega C$, and finally admittances add for parallel elements just like impedances add for series elements. So we're left with an impedance of $1/(g+j\omega C)$.

That impedance is in parallel with Z_0 , which might seem surprising. That Z_0 term comes from the fact that our wire model is a two-port model, so we have to hook something up in parallel with the conductor and capacitor to represent what the $V(x+dS,t)$ port is connected to. The trick here is that the segment we're looking at is differentially small, so removing it won't change the impedance seen looking into the rest of the transmission line. That means we see Z_0 looking into the $V(x+dS,t)$ port too.

Alright, with that equation set up we can do a bunch of tedious algebra. I'm going through the details of it because there's one step in the middle that is a good reminder of some a common physics approximations, but overall this is just turning the crank. CLICK first we make an algebraic expression for two things in parallel CLICK then we multiply both sides by the denominator of the second term on the right. This leaves us with a messy equation, but there are a bunch of ways to simplify it. CLICK we can subtract 1 from both sides, and we can also throw away the first term in this sum because it will wind up multiplied by dS^2 , and a squared differential is too small to care about. CLICK so we're left with a much more tractable equation CLICK which can be solved for our characteristic impedance!

Note that the dS variables cancelled, so this is not multiplied by a differential. It's an actual impedance that happens to be a ratio of two impedance densities. Also note that the plus/minus means we have two impedance solutions. That's because each solution corresponds to one of our candidate wave solutions: one is for right-travelling waves and the other for left-travelling waves, and the negative sign just means left travelling waves send current in the minus x direction.

Finally, as usual, making our line lossless yields a really nice expression. In a lossless line Z_0 is $\sqrt{l/c}$, and it doesn't change with frequency.

Types of Impedance in This Class

- Lumped Impedance Z , Normal impedance, a discrete R , multimeters
- Characteristic Impedance Z_0 , t line property, only seen by waves, 50 ohm
- Driving Point Impedance Z_{dp} , Thevenin at the t line input, time varying
- Radiation Resistance R_{rad} , Honorable mention, More on this later

8

Before we go any farther, it's important to get some definitions straight. We use the word impedance a lot in this class, but it can refer to several different things.

Lumped impedance is normal impedance. It refers to a discrete capacitor. This is what multimeters measure (because they only measure DC things).

Characteristic impedance is a property of transmission lines that describes how a differential segment behaves. The only things that interact with our distributed model are waves, so we can only infer the value of Z_0 by looking at how waves propagate and interact. We'll talk about some tools to measure waves soon. Also, note that 50 ohms is a common characteristic impedance for rather silly historical reasons. So if someone says a cable is 50 ohms, that's referring to a characteristic impedance and not a lumped impedance: a multimeter won't measure 50 ohms on a 50 ohm cable.

Driving Point Impedance is a fancy version of Thevenin impedance. This is the impedance that a driver perceives when it looks into a length of transmission line. It's important because we're going to see that driving point impedance can change with time as left-travelling waves go back and hit the driver.

Finally, radiation resistance gets an honorable mention here even though it uses the word

resistance and not impedance. Radiation resistance is a property of antennas, and we won't see it for a while, but keep an eye out.

Driving Point Impedance of Infinite T Line

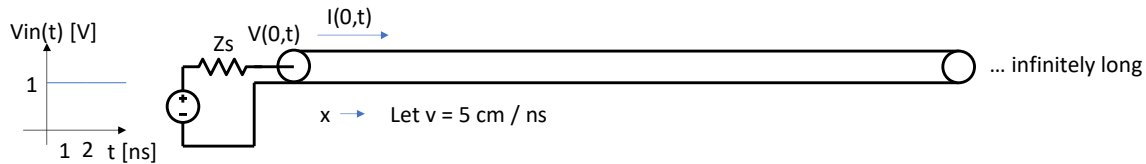

$$Z_{dp}(t) = \frac{V(0,t)}{I(0,t)} = \frac{V(0,t)}{V(0,t)/Z_0} = Z_0$$

Constant $V(0,t) \rightarrow Z_{dp}(t) = Z_0$

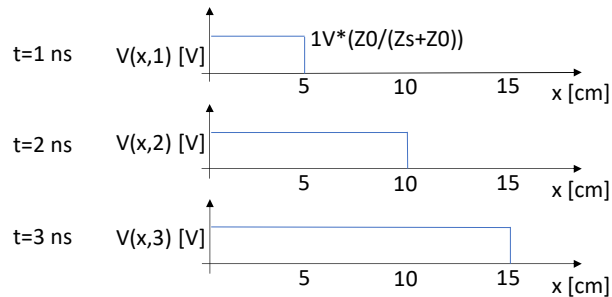

We're going to start exploring different kinds of impedance by calculating the driving point impedance of a transmission line. To do that, I've drawn a schematic here that shows a step function being driven into a transmission line. The function generator in this case has a source impedance of Z_s . We're calling the node between Z_s and the transmission line $V(0,t)$ and the current flowing into the transmission line $I(0,t)$.

The driving point impedance is $V(0,t)$ over $I(0,t)$ by definition, and $I(0,t)$ is $V(0,t)$ over Z_0 , which means the driving point impedance is equal to Z_0 in this example. Even though I've promised driving point impedance can vary with time, it isn't doing so here because the transmission line is infinitely long.

This value of driving point impedance has a few other effects. **CLICK** First, if we look at the wave propagating down the line, we see that the height is set by a voltage divider between Z_s and Z_{dp} . Second, we might also notice that Z_{dp} is a real impedance, which suggests that our power supply is dissipating real power in it. That's weird since this is a lossless transmission line made entirely out of lossless inductors and capacitors. We can resolve that paradox because power appears to be lost from the perspective of V_{in} : it flows down the transmission line forever and never comes back.

Summary

- We find the current in a transmission line by taking $V(x,t)/Z_0$
- Z_0 is called the characteristic impedance, and for lossless lines $Z_0 = \pm\sqrt{l/c}$
- The driving point impedance of an infinite transmission line is Z_0
- Impedance can mean a lot of things in this class, be specific

Loads on Transmission Lines

Matthew Spencer

Harvey Mudd College

E157 – Radio Frequency Circuit Design

In this video we're going to find the voltage in a transmission line with a finite length that is loaded with an impedance.

Resistive Loads Create Left-Travelling Waves

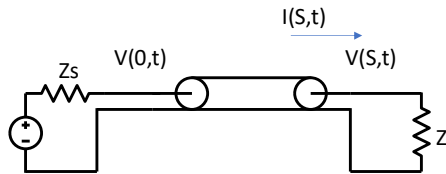

$$I(S, t) = V(S, t)/Z_l \quad \text{AND} \quad I(S, t) = V(S, t)/Z_0 \quad \leftarrow \text{Apparent contradiction for } Z_l \neq Z_0$$

$$V(x, t) = V_+(x - vt) + V_-(x + vt) \quad \leftarrow \text{Resolved by general solution}$$

$$\frac{V_+(S, t)}{Z_0} - \frac{V_-(S, t)}{Z_0} = \frac{V(S, t)}{Z_l} \quad \text{AND} \quad V_+(S, t) + V_-(S, t) = V(S, t) \quad \leftarrow \text{Current and voltage continuity at } S$$

$$\frac{V_-(S, t)}{V_+(S, t)} = \frac{Z_l - Z_0}{Z_l + Z_0} \quad \text{Called Reflection Coefficient, } \Gamma \quad \leftarrow \text{Some algebra}$$

12

I've put our usual transmission line picture on this slide, with a source impedance Z_s and a load impedance Z_l . I've also added variables describing the voltage and current at the end of the line: $V(S, t)$ and $I(S, t)$

CLICK This termination presents us with a thorny math issue though. We need current continuity at S , but we have two different equations defining the current. The transmission line thinks $I(S, t)$ should be $V(S, t)$ over Z_0 , while the load thinks $I(S, t)$ should be $V(S, t)$ over Z_l . CLICK We resolve this using the full, general solution for waves on a line, which is a sum of both of our candidate solutions. If we introduce a left travelling wave at the load, which we usually call a reflection, then we can get the math to work out. Note that I've used different symbols for the shapes of the right travelling and left travelling waves: I called them V_+ and V_- respectively. That's because our solution never guaranteed that the right and left travelling waves would be the same shape, and some boundary conditions can require the two waves to be shaped differently.

CLICK Armed with another degree of freedom from V_- , we can define current continuity and voltage continuity conditions at S . The V_+ and V_- voltages are added together, so their sum needs to equal $V(S, t)$. The right travelling and left travelling currents are subtracted from one another, which you can understand from a physics point of view (because the current wave is being reflected from the load and charge is going backwards) or from a

math point of view (because the impedance for a reverse-going wave is $-Z_0$, which makes $V(S,t)$ divided by the impedance a negative number). CLICK If you then do some algebra to rearrange these equations, you can find the ratio of the left travelling wave amplitude to the right travelling wave amplitude, which is a useful quantity called the reflection coefficient, and we give it the symbol Γ . The left going wave will be generated at the boundary condition and propagate to the left just the like the forward going wave.

Summary

- Resistive loads create left-travelling waves, which are reflections of the incident wave.
- This is because boundary conditions at a load requires current continuity.
- We describe the size of the reflected wave with a reflection coefficient

$$\Gamma = \frac{V_-(S, t)}{V_+(S, t)} = \frac{Z_L - Z_0}{Z_L + Z_0}$$

Termination Examples and Physical Insights

Matthew Spencer

Harvey Mudd College

E157 – Radio Frequency Circuit Design

In this video we're going to deploy our new knowledge of the reflection coefficient to look at some common terminations. We'll also try to get a physics understanding of what's happening to charge in transmission lines.

$Z_L = Z_0$ Has No Reflection

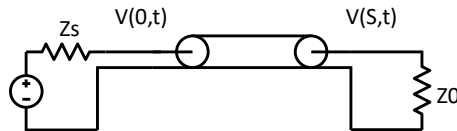

$$\Gamma = \frac{Z_L - Z_0}{Z_L + Z_0} = 0$$

- Desirable for many designs, good power delivery, easy to understand.
- Intuition: looks just like an infinite line to a wave front.

Our first example is terminating a transmission line in Z_0 . This results in a reflection coefficient of 0 because Z_L minus Z_0 is zero, so there are no reflections. This is desirable for a lot of designs, and if you've ever heard anyone refer to impedance matching, that vocabulary word refers to attempts to create this condition. An impedance matched load absorbs power well, and it doesn't throw power back into your transmitter, which can cause problems.

I also like to think about the lack of reflections in an impedance matched line from the point of view of the wave in the wire. The right-propagating wave is used to seeing an impedance of Z_0 , so it can't tell the difference between a termination of Z_0 and an infinite transmission line. Driving $V(S,t)/Z_0$ current into the load is just the same as driving $V(S,t)/Z_0$ current into the next wire differential.

ZL = Open Circuit Zeroes Current at Load

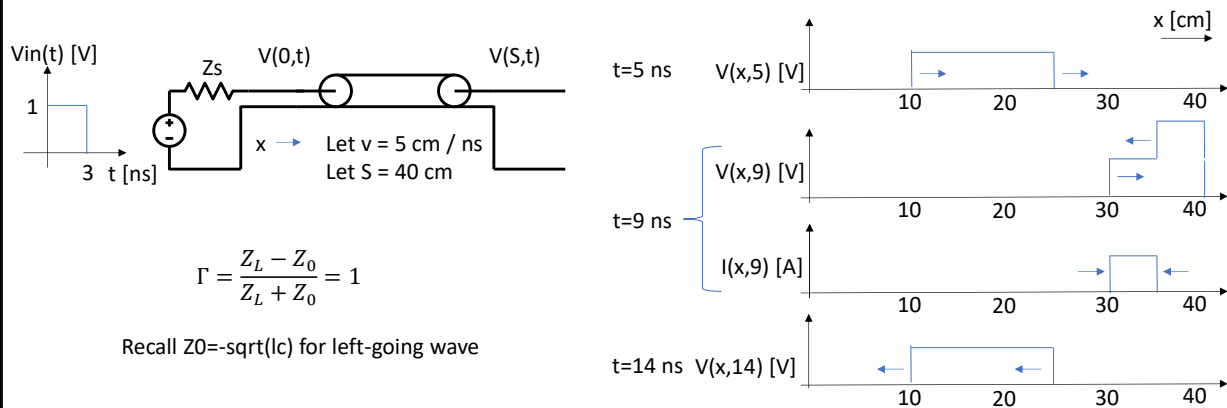

- Intuition: charge is piling up and going back, so double V and zero I

Next we're going to look at a transmission line terminated in an open circuit. Because Z_L is infinite in this case, we find that the reflection coefficient is 1, so the left-travelling wave is going to have the same amplitude as the right-travelling wave. Also, just a reminder, left travelling waves have a negative value for their characteristic impedance, which indicates current flows in the left direction for left-travelling waves. The transmission line we're going to study is pictured here. Note that it's being driven by a 2ns long voltage pulse.

CLICK I illustrate how voltage on the line will change as the pulse hits the load in these figures on the right. I've marked an arrow on each edge of the diagram to show which way the edges are travelling because in some subfigures we'll see both right and left travelling waves. At $t=5\text{ns}$, we see the pulse that we've launched into the line propagating right, just like in an infinite line. At $t=9\text{ns}$ we see the pulse is in the process of being reflected off of the open circuit. As the pulse is incident on the load, it creates a reverse going pulse. Because the pulse has been in contact with the load for 5ns, we see that a reverse-going wave has been generated for 5ns. From a math standpoint, the left-travelling wave has the same voltage as the right-travelling wave, and our two voltage solutions add, so we see double the voltage at the load. The currents subtract because the left-travelling wave has a negative characteristic impedance, so we see zero current at the load.

This is a really good result because it agrees with our physics intuition. First, the current at

the open circuit is zero, which is what we expect at an open circuit. Second, though this picture is not quite physically correct, we can imagine this travelling voltage pulse as a moving pile of charge. When the charge runs into the open circuit, it piles up, which increases the voltage, and creates an electrostatic force that pushes against other charges of the same time. This causes charge to move in the reverse direction, and the right-travelling and left-travelling flows of charge cancel out to leave zero current.

Finally, at $t=14\text{ns}$ we can see the voltage pulse propagating back towards the source. At this time, there is only a left-travelling wave and not a right travelling wave.

Zs Can Cause Reflections, Zdp is Consistent

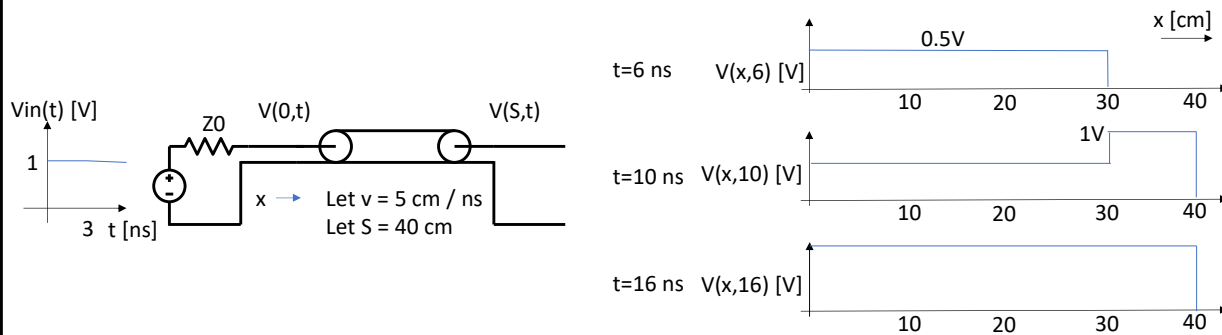

- At 16ns $V_{in}(t)=V(0,t)$, so no current through Z_s .
- $Z_{dp}(6ns)=Z_0$, $Z_{dp}(10ns)=Z_0$, $Z_{dp}(16ns)=\infty$ ← driving an open

$$\Gamma_{at\ input} = \frac{Z_s - Z_0}{Z_s + Z_0} = 0 \text{ in this case}$$

On this slide we're looking at a situation that's a little different than last slide even though the transmission line is still loaded by an open circuit. In this slide $V_{in}(t)$ is now a step function, not a pulse. Also, Z_s is equal to Z_0 on this slide.

We see the step propagating down the line in the 6ns figure, and it has a height of 0.5V. That's because of a voltage divider between Z_s and Z_{dp} . We've only technically figured out the driving point impedance for an infinite transmission line, but we can say that $V(0,6ns)/I(0,6ns)$ is equal to Z_0 because there is only a forward travelling wave right now, and each of our candidate waves has to individually obey $V(x,t)/I(x,t)=Z_0$. Because both the source and driving point impedances are Z_0 , we see a divider factor of one half.

In the 10ns figure, we can see that the wave front has reflected off the open circuit and the voltage doubles as the left-travelling wave is added to the right-travelling wave. The current will be zero in the region with doubled voltage just like it was on the last slide.

Finally, the wave front reaches the source at $t=16ns$. There are two things to discuss about the wave front reaching the source. First, the wave front could potentially reflect off of the source impedance. In this example we've set the source impedance to Z_0 , so the left-travelling wave doesn't have a reflection. But it's important to remember that one can happen in a general case. You'll notice that if both the source and the load are impedance

mismatched, you could get a wave reflecting off the load, and then off the source and then off the load again, and that happens in the real world. It makes the voltage on the line very hard to predict, though attenuation in the real world also reduces the size of the waves during each trip so they don't bounce around forever. You'll also notice that I ignore the voltage source when I'm calculating the reflection coefficient, which is because the Thevenin impedance of ideal voltage sources is 0.

The second thing to discuss is that the driving point impedance changes when the left-travelling wave reaches the driver. The right-travelling and left-travelling waves each have an amplitude of 0.5V and generate $0.5V/Z_0$ of current in the forward or backward direction, but the source sees the sum of the waves at $t=16\text{ns}$, which has an amplitude of 1V and pulls zero current. The driving point impedance is always equal to $V(0,t)/I(0,t)$, and because $I(0,t)$ is zero, $Z_{dp}(t)$ is infinite, or said another way, the driving point impedance is now an open circuit. This is actually really cool, because it matches with any previous experience you've had in a lab. If you hooked a multimeter up to one side of a BNC cable with the other side open circuited, you would measure infinite resistance. This changing value of $Z_{dp}(t)$ is consistent with that; 16ns after applying a voltage to measure how much current comes out, your multimeter would see an answer of 0, and multimeters don't update fast enough to see what happens 16ns after they're hooked up.

The changing value of $Z_{dp}(t)$ is also cool because you can think of it in terms of "information about the load" making it back to the source. The driving point impedance has to wait for a left travelling wave before it changes, so the driver can't perceive what the load is any faster than 16ns. Here we see that after 16ns the driving point impedance becomes consistent with information about the load carried on the left-travelling wave.

Summary

- Terminating in Z_0 causes no reflections
- Reflected I subtracts from incident I , reflected V adds
- $Z_{dp}(t)$ changes with time to reflect information at source about load
- Z_s can cause reflections and voltage sources have zero impedance