

Common Emitter Linearity and a Design Example

Matthew Spencer

Harvey Mudd College

E151 – Analog Circuit Design

1

In this video series we're going to talk about our ways that our generic amplifier model fails. Though we use small signal models to describe amplifiers, we're describing a system that is non-linear at it's heart, and we'll capture that behavior with the idea of output voltage swing and percent transconductance deviation. We're also going to go through a design example for a common emitter amplifier, which I hope will be useful in your next lab, and round up a few more amplifier design specs.

Output Voltage Swing

Matthew Spencer

Harvey Mudd College

E151 – Analog Circuit Design

2

In this video we're going to talk about how to identify a common failure mode of common emitter amplifiers: forcing the transistor out of the forward active region. When the transistor leaves the forward active region, our small signal model to fail because it was derived presuming forward active operation of the transistor. This will result in a non-sinusoidal output waveform that is referred to as "clipped".

The Amplifier Only Works if BJT is in FAR

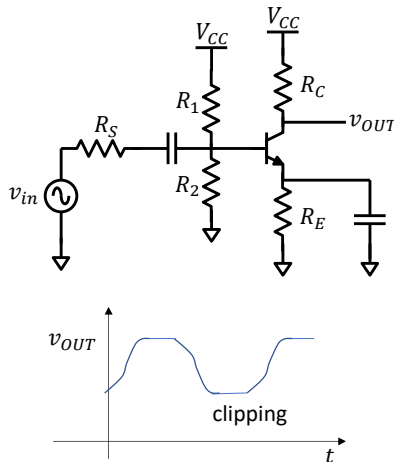

- Let $V_{CC}=10V$, $I_C=1mA$, $R_E=2k\Omega$, and $R_C=4k\Omega$
- Implies $V_{OUT}=6V$, $V_E=2V$.
- If v_{OUT} increases by 4V, $I_C=0mA$ and the transistor is cut off.
- If v_{OUT} decreases by 3.8V the transistor becomes saturated.
- Output voltage swing, V_{SW} , is $2 \min(V_{OMAX} - V_o, V_o - V_{OMIN})$

3

The behavior we see when our amplifier leaves the forward active region is called clipping, and a clipped waveform is pictured at the bottom of the slide. v_{OUT} is no longer able to track the input voltage at the peaks and troughs of the wave because the transistor turns off or saturates. This example was drawn presuming a sinusoidal input, and we can see the output is no longer a sinusoid.

Clipping at V_{CC} can be conceived of as a pretty pedestrian problem: our voltage obviously can't go outside of the voltage rails that supply our amplifier. However, there are more subtleties involved in this clipping behavior. For example, our low clipping level isn't at ground, so what's stopping the voltage from going lower?

CLICK We're going to make this circuit a little more concrete to imagine what's going on. Let's assume V_{CC} is 10V, I_C is 1mA, R_E is 2kiloohms and R_C is 4kilo-ohms.

CLICK We can then calculate the large signal voltages at a few important nodes. The large signal output voltage is given by $V_{CC}-I_C \cdot R_C$, which is 6V. The large signal emitter voltage is given by $I_C \cdot R_E$, which is 2V. We are assuming I_C is about the same as I_E to make that last calculation.

CLICK However, wiggling our base around will cause small signal changes to be

superimposed on the large signal collector voltage at the output. That means the total signal v_{OUT} moves around. If total signal v_{OUT} increases by 4V, which happens when the base is decreased by some amount, then we can calculate the instantaneous collector current to be zero because the total signal v_{OUT} is given by $V_{CC} - i_C R_C$ too, so i_C has to be zero when $v_{OUT} = V_{CC}$. However, we only have no current in our collector when our transistor is cut off, so decreasing i_C to 0mA causes the transistor to enter the cutoff region. Trying to increase our voltage further doesn't work because a cut off transistor won't respond to further decreases in v_{BE} .

We call the maximum voltage our transistor can achieve V_{OMAX} , and V_{OMAX} will usually be V_{CC} in NPN amplifiers. However, V_{OMAX} is actually a bit shy of V_{CC} in practice because BJTs act a bit weird at very low current levels. You should make sure to give yourself an additional volt or two of safety margin on your upward voltage swing in your designs.

CLICK On the other hand, decreasing v_{OUT} implies that i_C has increased, so we don't have to worry about cutting off the transistor. However, if v_{OUT} reaches 2.2V, then we no longer have V_{CESAT} across the transistor, which causes it to enter the saturation region. We call the minimum acceptable output voltage for an amplifier V_{OMIN} .

CLICK We summarize these two behaviors by defining a new amplifier design parameter called the output voltage swing, or V_{SW} . The swing depends on the large signal output voltage and its distance from both the maximum and the minimum output voltages. Specifically, the voltage swing captures the peak-to-peak size of the largest wave you could have at the output without leaving forward active. That peak-to-peak size is going to be given by twice the distance from the large signal output voltage to the closer of V_{OMAX} and V_{OMIN} . For instance, in our example v_{OUT} can travel 4V upward before cutoff, but only 3.8V downward before saturation, therefore V_{SW} would be $2 * 3.8V$ or 7.6V.

Note that V_{SW} is a large signal calculation. It only depends on large signal voltages in the circuit. That said, students find calculating V_{SW} as a large signal value a bit funny because large signal voltages never change. That's because finding V_{OMAX} and V_{OMIN} implicitly acknowledges that your total signal output voltage is moving around enough to force the transistor into other regions of operation. So even though we call V_{SW} a large signal property, it only exists because we know there is a small signal superimposed on V_{OUT} .

Summary

- Common emitter output signals clip if they are too high or too low.
- Clipping happens when the transistor leaves the forward active region
- The max output voltage where the transistor is in FAR is V_{OMAX} , and the smallest output voltage where the transistor is in FAR is V_{OMIN} .
- Output voltage swing, V_{SW} , is an important amplifier specification.

$$V_{SW} = 2 \min(V_{OMAX} - V_o, V_o - V_{OMIN})$$

g_m Variation Nonlinearity

Matthew Spencer

Harvey Mudd College

E151 – Analog Circuit Design

5

In this video we're going to observe another effect that can cause a non-linear response, which is that g_m often changes during the operation of a common emitter amplifier.

Changing g_m Values Create a Nonlinear v_{OUT}

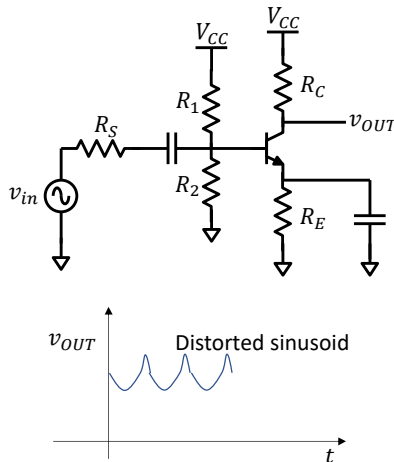

- Let $I_C = 1\text{mA}$ and $R_C = 4\text{k}\Omega$
- Implies
 $g_m = I_C / \phi_t = 40\text{mS}$,
 $a_v = -g_m R_C = -160$
- But $i_C = (V_{CC} - v_{OUT}) / R_C$, so changing v_{OUT} changes i_C
- This goes further:
 $v_{OUT} \rightarrow i_C \rightarrow g_m \rightarrow a_v$
- Changing a_v distorts the output. Distortion % described by i_C / I_C

6

You can see a cartoon depicting another non-linear output from a common emitter amplifier at the bottom of this page. Here the output sine wave looks different on top than on bottom, appearing pinched and probably not reaching the full zero-to-peak value you see at the bottom of the sine wave. We refer to any non-linear behavior in an amplifier's output as distortion, and common emitter amplifiers are very distortion prone for even modest output swings.

As a side note, this distortion can often be subtle, and I have trained myself to compare the top and bottom halves of sine waves at my output to pick up the first whiffs of a distorted signal.

CLICK Like last video, we'll make the amplifier a bit more concrete to see why. Here we presume that I_C is 1mA and R_C is 4kiloohms.

CLICK This implies that our g_m is 40mS, which we calculated at I_C over the thermal voltage, and that our voltage gain is -160.

CLICK However, when our output voltage moves around, that's because the instantaneous total signal current is also changing. I've captured that by rearranging the usual $v_{OUT} = V_{CC} - i_C \cdot R_C$ equation here.

CLICK That has a lot of knock-on effects. Changing v_{OUT} means changing i_C , which means changing instantaneous g_m , and because g_m shows up in our voltage gain it means changing a_v .

CLICK If a_v changes as our output wave moves around, that will result in an output wave that looks different than the input wave. Predicting the exact shape of the wave is involved, but you can get a quick guess at your % error by taking the ratio of your current gain to the gain you were aiming for, which reduces to the instantaneous total signal current over the large signal current.

This is a big problem with common emitters, but you can still use a common emitter amplifier as long as your output is still a legitimately small signal. We'll learn about other circuits that let us make lower distortion gains in the near future.

Summary

- Our CE gain is $-g_m R_C$, but g_m changes with changing i_C (equivalently, changes with changing v_{OUT}).
- This produces distortion, which looks like misshapen sinusoids. Often easy to spot if top half of wave doesn't match bottom.
- % distortion is given by i_C/I_C .

Example of Amplifier Design

Matthew Spencer

Harvey Mudd College

E151 – Analog Circuit Design

In this video we're going to go through the process of designing an amplifier together so that you can see my process. Designing your first amplifier can be intimidating, but I hope this example will demystify the process.

Changing g_m Values

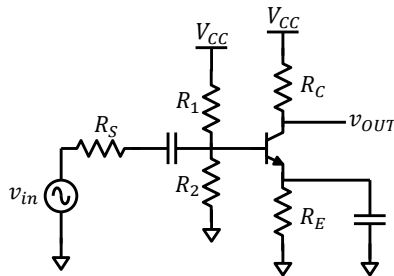

$$r_{in} = R_1 || R_2 || r_{\pi}$$

$$r_{out} \approx R_C$$

$$a_v \approx -g_m R_C$$

- Constraints: $V_{CC}=10V$, $\beta = 100$, $r_{out} < 2k\Omega$, $r_{in} > 1k\Omega$, $a_v = -100$.
- $r_{out} < 2k\Omega$ implies $R_C = 2k\Omega$.
- $R_C = 2k\Omega$ implies $g_m = 50mS$ to satisfy a_v .
- Sets $I_C = 1.25mA$, $V_O = 7.5V$, $r_{\pi} = 2k\Omega$.
- Need $R_1 \approx R_2 > r_{\pi}$ to get high r_{in} , so let $V_B=5V$. Implies $V_E = 4.3V$, $R_E = 3.44k\Omega$.
- Let $R_1 = R_2 = 5k\Omega$, see if it works.

9

Designing an amplifier is going from a set of specifications, like r_{in} , r_{out} and a_v , back to values of resistors, voltages and currents. In the amplifier pictured here, that means we need to pick R_1 , R_2 , R_C and R_E to set useful values of V_{OUT} , V_E , V_B and I_C . That's eight variables we have to pick or derive from other relationships. As a result, designing can feel like trying to wrangle a big pile of interconnected equations. It's even trickier because lots of designs are underconstrained, there's more than one set of values that would make them work. However, I find that if I pick a few constraints that let me pin down some values early, then you can follow the implications of those constraints through the rest of the design. Let's see an example.

For convenience, I've included the r_{in} , r_{out} and a_v for this amplifier. r_{out} and a_v are our standard expressions for a common emitter, and I've modified r_{in} to reflect that our bias network falls in parallel with r_{π} , which is the small signal impedance seen from the base.

CLICK We're going to start with a set of constraints, some of which are technically device properties rather than design constraints. Here we set V_{CC} to 10V, β to 100, and say that we want r_{out} less than 2kiloohms, r_{in} greater than 1kiloohm and an a_v of -100.

CLICK We can launch from one of these constraints to a resistor value right away. r_{out} is just equal to R_C , so we know R_C has to be less than 2kiloohms. This statement doesn't give

us an exact RC value, which is a problem. Life is a lot easier if we pick just one RC value because we can use that to specify other values., so I'm going to pick an RC value here. Specifically, I'm going to set RC equal to 2kiloohms.

It can be tempting to try to leave RC defined by an inequality, maybe in hopes of getting a mathematically perfect value for it later. That way lies madness. There are a lot of moving variables in a circuit design, and you'll do better if you just pick values for some elements for your first few designs.

Though it undermines my previous point a bit, it's worth noting that I picked RC=2kiloohms because that means I can use a smaller IC to get the gain I want, which will minimize power consumption in the amplifier. One unspoken constraint in almost every design is that you want to minimize power consumption. It's rare that you have so much power available that you don't want to think about it.

CLICK If we know RC, then we can find the gm we want in order to get our gain at the right value.

CLICK and that in turn implies an IC value because gm is equal to IC over ϕ_t . Finding IC is a big deal in an amplifier design, and it usually cracks the design wide open. In our case, it tells us that our large signal VO, which is $V_{CC} - I_C \cdot R_C$, will be 7.5V, and that r_{pi} , which is $\beta \cdot \phi_t / I_C$, is going to be 2kiloohm.

CLICK We have some freedom in picking VB and VE, which makes this next step a bit fuzzy. However, we haven't guaranteed that our r_{in} is going to work right yet, so it makes sense to start picking values that will help us meet the r_{in} constraint. Because R1 and R2 are in parallel with r_{pi} , we need them to be bigger than r_{in} and possibly significantly bigger than r_{pi} . Further, because the parallel operator favors the minimum value it operates on, it doesn't help to make R1 much bigger or smaller than R2. So let's assume they're about the same, which will put VB at 5V. VE is a VBEON drop below VB, so it will be at 4.3V. If VE is going to be at 4.3V, then we can use that knowledge to pick RE, which will set IC in turn. So we write $VE = I_E \cdot R_E$ and remember that I_E is about the same as I_C , and we find that RE should be 3.44kiloohm.

This is a pretty specific value for a resistor, and we may not be able to find it in lab. That raises a lot of questions, like "Could I get away with a 3.3k resistor I have lying around? And in turn, "how exact does IC need to be"? Which further suggests, "Does our gain need to be right at -100"? These are important questions you should kick back to your client. You could also adjust your design a bit to avoid needing this weird resistor by picking a different RC. I strongly recommended partially automating your design process using a spreadsheet so you can repeat earlier steps if your find yourself asking these questions.

CLICK Finally, we need to pick R1 and R2, and I've let them be 5kiloohms. I double checked that this value will meet our r_{in} constraint, and this value also means that a fairly high

current, of 1mA, passes through the bias network. That means we're likely to get the base voltage we're looking for without the base current of 12.5microamps messing with our bias point. That said, there are a plenty of other choices you could have made for these resistors. It's also possible to go through this design in the opposite direction, setting R1, R2 and rpi first, and using those values to inform RC and RE. Puzzling out the many paths through a design and the hidden relationships underneath them can be a really fun exercise.

... can I find a 3.4k resistor? How close do I need to be to -100 gain?

... draw small signal models?

Summary

- Amplifier design can be intimidating.
- Use constraints to pin down key values, then propagate them.
- Where you have freedom, pick values that are convenient.