

# SOLUTIONS

# CHAPTER 1

## Exercise 1.1

---

(a) Biologists study cells at many levels. The cells are built from organelles such as the mitochondria, ribosomes, and chloroplasts. Organelles are built of macromolecules such as proteins, lipids, nucleic acids, and carbohydrates. These biochemical macromolecules are built simpler molecules such as carbon chains and amino acids. When studying at one of these levels of abstraction, biologists are usually interested in the levels above and below: what the structures at that level are used to build, and how the structures themselves are built.

(b) The fundamental building blocks of chemistry are electrons, protons, and neutrons (physicists are interested in how the protons and neutrons are built). These blocks combine to form atoms. Atoms combine to form molecules. For example, when chemists study molecules, they can abstract away the lower levels of detail so that they can describe the general properties of a molecule such as benzene without having to calculate the motion of the individual electrons in the molecule.

## Exercise 1.3

---

Ben can use a hierarchy to design the house. First, he can decide how many bedrooms, bathrooms, kitchens, and other rooms he would like. He can then jump up a level of hierarchy to decide the overall layout and dimensions of the house. At the top-level of the hierarchy, he material he would like to use, what kind of roof, etc. He can then jump to an even lower level of hierarchy to decide the specific layout of each room, where he would like to place the doors, windows, etc. He can use the principle of regularity in planning the framing of the house. By using the same type of material, he can scale the framing depending on the dimensions of each room. He can also use regularity to choose the same (or a small set of) doors and windows for each room. That way, when he places

a new door or window he need not redesign the size, material, layout specifications from scratch. This is also an example of modularity: once he has designed the specifications for the windows in one room, for example, he need not re-specify them when he uses the same windows in another room. This will save him both design time and, thus, money. He could also save by buying some items (like windows) in bulk.

**Exercise 1.5**

---

(a) The hour hand can be resolved to  $12 * 4 = 48$  positions, which represents  $\log_2 48 = 5.58$  bits of information. (b) Knowing whether it is before or after noon adds one more bit.

**Exercise 1.7**

---

$2^{16} = 65,536$  numbers.

**Exercise 1.9**

---

(a)  $2^{16}-1 = 65535$ ; (b)  $2^{15}-1 = 32767$ ; (c)  $2^{15}-1 = 32767$

**Exercise 1.11**

---

(a) 0; (b)  $-2^{15} = -32768$ ; (c)  $-(2^{15}-1) = -32767$

**Exercise 1.13**

---

(a) 10; (b) 54; (c) 240; (d) 2215

**Exercise 1.15**

---

(a) A; (b) 36; (c) F0; (d) 8A7

**Exercise 1.17**

---

(a) 165; (b) 59; (c) 65535; (d) 3489660928

**Exercise 1.19**

---

(a) 10100101; (b) 00111011; (c) 1111111111111111;  
(d) 11010000000000000000000000000000

**Exercise 1.21**

---

(a) -6; (b) -10; (c) 112; (d) -97

**Exercise 1.23**

---

(a) -2; (b) -22; (c) 112; (d) -31

**Exercise 1.25**

---

(a) 101010; (b) 111111; (c) 11100101; (d) 1101001101

**Exercise 1.27**

---

(a) 2A; (b) 3F; (c) E5; (d) 34D

**Exercise 1.29**

---

(a) 00101010; (b) 11000001; (c) 01111100; (d) 10000000; (e) overflow

**Exercise 1.31**

---

00101010; (b) 10111111; (c) 01111100; (d) overflow; (e) overflow

**Exercise 1.33**

---

(a) 00000101; (b) 11111010

**Exercise 1.35**

---

(a) 00000101; (b) 00001010

**Exercise 1.37**

---

(a) 52; (b) 77; (c) 345; (d) 1515

**Exercise 1.39**

---

(a)  $100010_2$ ,  $22_{16}$ ,  $34_{10}$ ; (b)  $110011_2$ ,  $33_{16}$ ,  $51_{10}$ ; (c)  $010101101_2$ ,  $AD_{16}$ ,  $173_{10}$ ; (d)  $011000100111_2$ ,  $627_{16}$ ,  $1575_{10}$

**Exercise 1.41**

---

15 greater than 0, 16 less than 0; 15 greater and 15 less for sign/magnitude

**Exercise 1.43**

---

4, 8

**Exercise 1.45**

---

5,760,000

**Exercise 1.47**

---

46.566 gigabytes

**Exercise 1.49**

---

128 kbits

**Exercise 1.51**

---

	-2	-1	0	1	2	3	
Unsigned			00	01	10	11	
	10	11	00	01			Two's Complement
		11	00 10	01			Sign/Magnitude

**Exercise 1.53**

---

(a) 11011101; (b) 110001000 (overflows)

**Exercise 1.55**

---

(a) 11011101; (b) 110001000

**Exercise 1.57**

---

- (a)  $000111 + 001101 = 010100$
- (b)  $010001 + 011001 = 101010$ , overflow
- (c)  $100110 + 001000 = 101110$

- (d)  $011111 + 110010 = 010001$
- (e)  $101101 + 101010 = 010111$ , overflow
- (f)  $111110 + 100011 = 100001$

**Exercise 1.59**

---

- (a) 0x2A; (b) 0x9F; (c) 0xFE; (d) 0x66, overflow

**Exercise 1.61**

---

- (a)  $010010 + 110100 = 000110$ ; (b)  $011110 + 110111 = 010101$ ; (c)  $100100 + 111101 = 100001$ ; (d)  $110000 + 101011 = 011011$ , overflow

**Exercise 1.63**

---

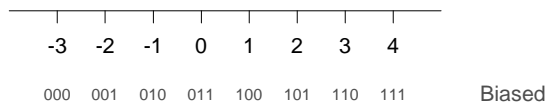

**Exercise 1.65**

---

- (a) 0011 0111 0001
- (b) 187
- (c)  $95 = 1011111$
- (d) Addition of BCD numbers doesn't work directly. Also, the representation doesn't maximize the amount of information that can be stored; for example 2 BCD digits requires 8 bits and can store up to 100 values (0-99) - unsigned 8-bit binary can store 28 (256) values.

**Exercise 1.67**

---

Both of them are full of it.  $42_{10} = 101010_2$ , which has 3 1's in its representation.

**Exercise 1.69**

---

```
#include <stdio.h>

void main(void)
{
    char bin[80];
    int i = 0, dec = 0;

    printf("Enter binary number: ");
    scanf("%s", bin);
```

```

while (bin[i] != 0) {
    if (bin[i] == '0') dec = dec * 2;
    else if (bin[i] == '1') dec = dec * 2 + 1;
    else printf("Bad character %c in the number.\n", bin[i]);
    i = i + 1;
}
printf("The decimal equivalent is %d\n", dec);
}
    
```

**Exercise 1.71**

---

**OR3**

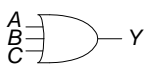

$Y = A + B + C$

A	B	C	Y
0	0	0	0
0	0	1	1
0	1	0	1
0	1	1	1
1	0	0	1
1	0	1	1
1	1	0	1
1	1	1	1

(a)

**XOR3**

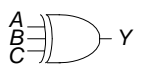

$Y = A \oplus B \oplus C$

A	B	C	Y
0	0	0	0
0	0	1	1
0	1	0	1
0	1	1	0
1	0	0	1
1	0	1	0
1	1	0	0
1	1	1	1

(b)

**XNOR4**

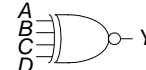

$Y = \overline{A \oplus B \oplus C \oplus D}$

A	C	B	D	Y
0	0	0	0	1
0	0	0	1	0
0	0	1	0	0
0	0	1	1	1
0	1	0	0	0
0	1	0	1	1
0	1	1	0	1
0	1	1	1	0
1	0	0	0	0
1	0	0	1	1
1	0	1	0	1
1	0	1	1	0
1	1	0	0	1
1	1	0	1	0
1	1	1	0	0
1	1	1	1	1

(c)

**Exercise 1.73**

---

A	B	C	Y
0	0	0	0
0	0	1	0
0	1	0	0
0	1	1	1
1	0	0	0
1	0	1	1
1	1	0	1
1	1	1	1

**Exercise 1.75**

---

A	B	C	Y
0	0	0	1
0	0	1	1
0	1	0	1
0	1	1	0
1	0	0	1
1	0	1	0
1	1	0	1
1	1	1	0

**Exercise 1.77**

---

$$2^{2^N}$$

**Exercise 1.79**

---

No, there is no legal set of logic levels. The slope of the transfer characteristic never is better than -1, so the system never has any gain to compensate for noise.

**Exercise 1.81**

---

The circuit functions as a buffer with logic levels  $V_{IL} = 1.5$ ;  $V_{IH} = 1.8$ ;  $V_{OL} = 1.2$ ;  $V_{OH} = 3.0$ . It can receive inputs from LVCMOS and LVTTL gates because their output logic levels are compatible with this gate's input levels. However, it cannot drive LVCMOS or LVTTL gates because the 1.2  $V_{OL}$  exceeds the  $V_{IL}$  of LVCMOS and LVTTL.

**Exercise 1.83**

---

(a) XOR gate; (b)  $V_{IL} = 1.25$ ;  $V_{IH} = 2$ ;  $V_{OL} = 0$ ;  $V_{OH} = 3$

**Exercise 1.85**

---



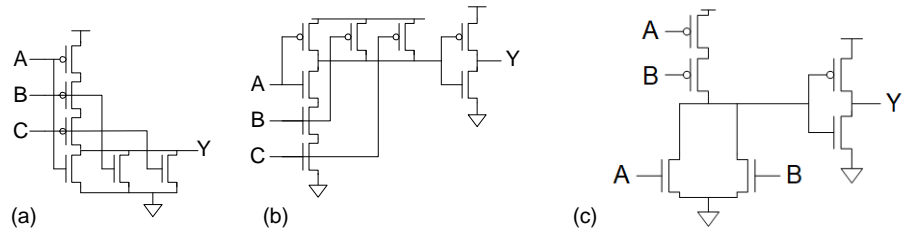

**Exercise 1.87**

---

XOR

A	B	Y
0	0	0
0	1	1
1	0	1
1	1	0

**Exercise 1.89**

---

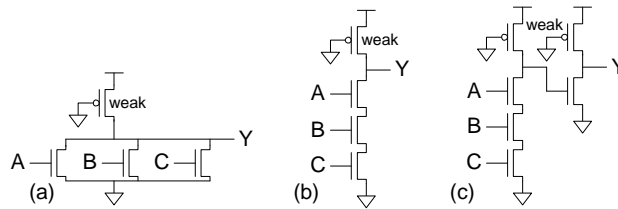

**Question 1.1**

---

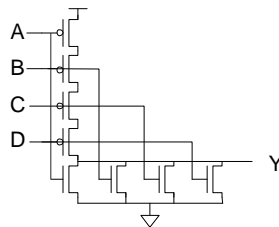

**Question 1.3**

---

17 minutes: (1) designer and freshman cross (2 minutes); (2) freshman returns (1 minute); (3) professor and TA cross (10 minutes); (4) designer returns (2 minutes); (5) designer and freshman cross (2 minutes).

# CHAPTER 2

## Exercise 2.1

---

(a)  $Y = \bar{\bar{A}}\bar{B} + A\bar{B} + AB$

(b)  $Y = \bar{\bar{A}}\bar{\bar{B}}\bar{C} + ABC$

(c)  $Y = \bar{\bar{A}}\bar{\bar{B}}\bar{C} + \bar{\bar{A}}\bar{B}\bar{C} + \bar{\bar{A}}\bar{\bar{B}}\bar{C} + A\bar{B}\bar{C} + ABC$

(d)

$$Y = \bar{\bar{A}}\bar{\bar{B}}\bar{\bar{C}}\bar{\bar{D}} + \bar{\bar{A}}\bar{\bar{B}}\bar{\bar{C}}\bar{D} + \bar{\bar{A}}\bar{\bar{B}}\bar{C}\bar{D} + \bar{\bar{A}}\bar{B}\bar{C}\bar{D} + \bar{\bar{A}}\bar{\bar{B}}\bar{C}\bar{D} + \bar{\bar{A}}\bar{B}\bar{C}\bar{D} + \bar{\bar{A}}\bar{B}\bar{C}\bar{D}$$

(e)

$$Y = \bar{\bar{A}}\bar{\bar{B}}\bar{\bar{C}}\bar{\bar{D}} + \bar{\bar{A}}\bar{\bar{B}}\bar{C}\bar{D} + \bar{\bar{A}}\bar{B}\bar{C}\bar{D} + \bar{\bar{A}}\bar{B}\bar{C}\bar{D} + \bar{\bar{A}}\bar{\bar{B}}\bar{C}\bar{D} + \bar{\bar{A}}\bar{B}\bar{C}\bar{D} + \bar{\bar{A}}\bar{B}\bar{C}\bar{D} + \bar{\bar{A}}\bar{B}\bar{C}\bar{D}$$

## Exercise 2.3

---

(a)  $Y = (A + \bar{B})$

(b)

$$Y = (A + B + \bar{C})(A + \bar{B} + C)(A + \bar{B} + \bar{C})(\bar{A} + B + C)(\bar{A} + B + \bar{C})(\bar{A} + \bar{B} + C)$$

(c)  $Y = (A + B + \bar{C})(A + \bar{B} + \bar{C})(\bar{A} + \bar{B} + C)$

(d)

$$Y = (A + \bar{B} + \bar{C} + \bar{D})(\bar{A} + \bar{B} + C + \bar{D})(\bar{A} + \bar{B} + \bar{C} + D)(\bar{A} + \bar{B} + \bar{C} + \bar{D})(\bar{A} + B + C + \bar{D})(\bar{A} + B + \bar{C} + D)(\bar{A} + B + C + D)(\bar{A} + B + \bar{C} + D)$$

(e)

$$Y = (A + B + C + \bar{D})(A + B + \bar{C} + D)(A + \bar{B} + C + D)(A + \bar{B} + \bar{C} + \bar{D})(\bar{A} + B + C + D)(\bar{A} + B + \bar{C} + D)(\bar{A} + \bar{B} + C + D)(\bar{A} + \bar{B} + \bar{C} + D)$$

**Exercise 2.5**

---

(a)  $Y = A + \bar{B}$

(b)  $Y = \bar{A}\bar{B}\bar{C} + ABC$

(c)  $Y = \bar{A}\bar{C} + \bar{A}\bar{B} + AC$

(d)  $Y = \bar{A}\bar{B} + \bar{B}\bar{D} + AC\bar{D}$

(e)

$$Y = \bar{A}\bar{B}\bar{C}\bar{D} + \bar{A}\bar{B}C\bar{D} + \bar{A}B\bar{C}\bar{D} + \bar{A}BC\bar{D} + A\bar{B}\bar{C}\bar{D} + A\bar{B}C\bar{D} + AB\bar{C}\bar{D} + ABC\bar{D}$$

This can also be expressed as:

$$Y = \overline{(A \oplus B)(C \oplus D)} + (A \oplus B)(C \oplus D)$$

**Exercise 2.7**

---

(a)

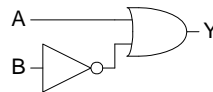

(b)

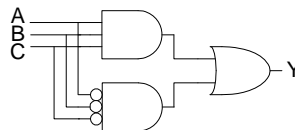

(c)

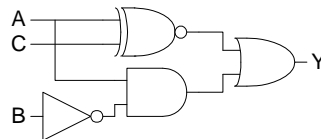

(d)

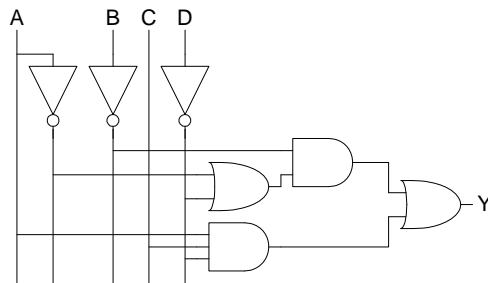

(e)

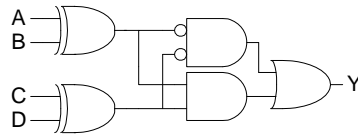

**Exercise 2.9**

---

(a) Same as 2.7(a)

(b)

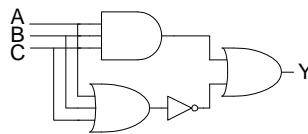

(c)

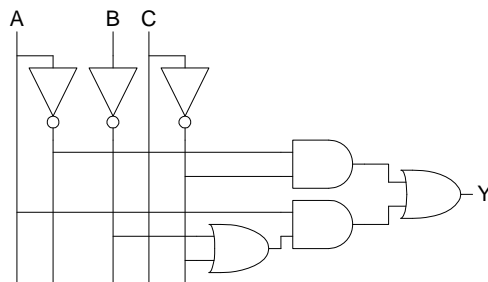

(d)

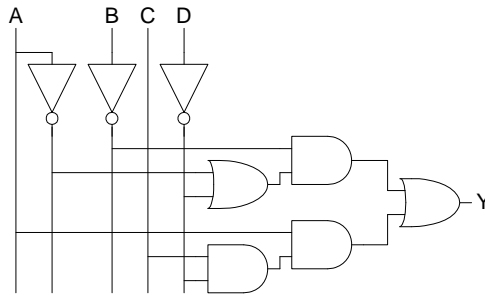

(e)

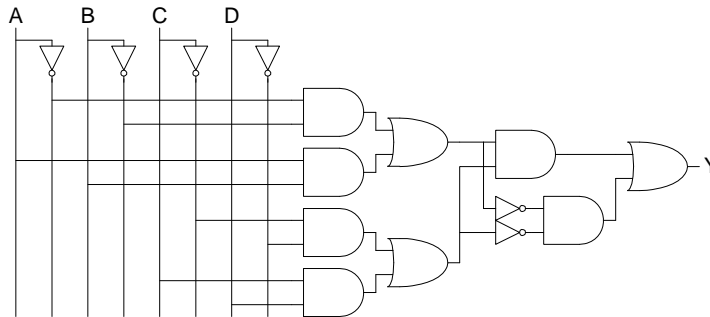

**Exercise 2.11**

---

(a)

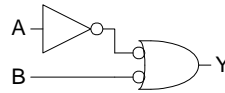

(b)

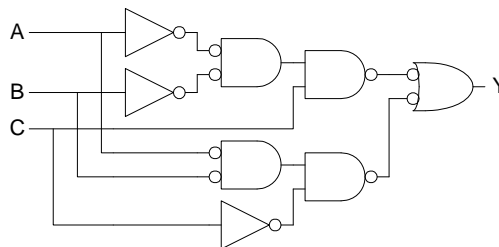

(c)

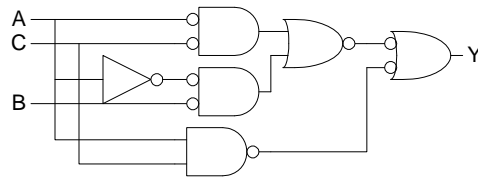

(d)

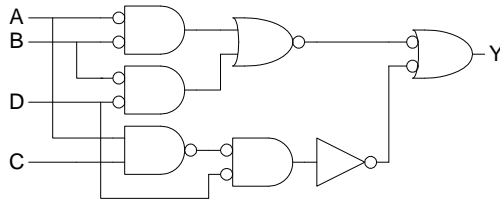

(e)

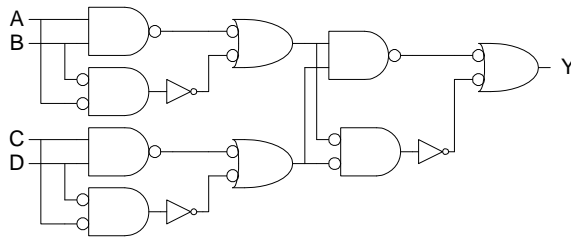

**Exercise 2.13**

---

(a)  $Y = AC + \overline{B}C$

(b)  $Y = \overline{A}$

(c)  $Y = \overline{A} + \overline{B}\overline{C} + \overline{B}\overline{D} + BD$

**Exercise 2.15**

---

(a)

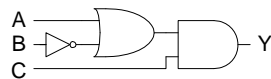

(b)

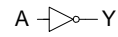

(c)

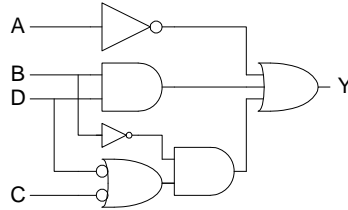

**Exercise 2.17**

---

(a)  $Y = B + \bar{A}\bar{C}$



(b)  $Y = \bar{A}B$

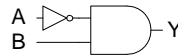

(c)  $Y = A + \bar{B}\bar{C} + \bar{D}\bar{E}$

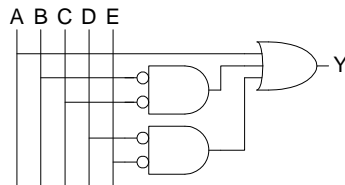

**Exercise 2.19**

---



4 gigarows =  $4 \times 2^{30}$  rows =  $2^{32}$  rows, so the truth table has 32 inputs.

**Exercise 2.21**

Ben is correct. For example, the following function, shown as a K-map, has two possible minimal sum-of-products expressions. Thus, although  $\overline{A}\overline{C}\overline{D}$  and  $\overline{B}\overline{C}\overline{D}$  are both prime implicants, the minimal sum-of-products expression does not have both of them.

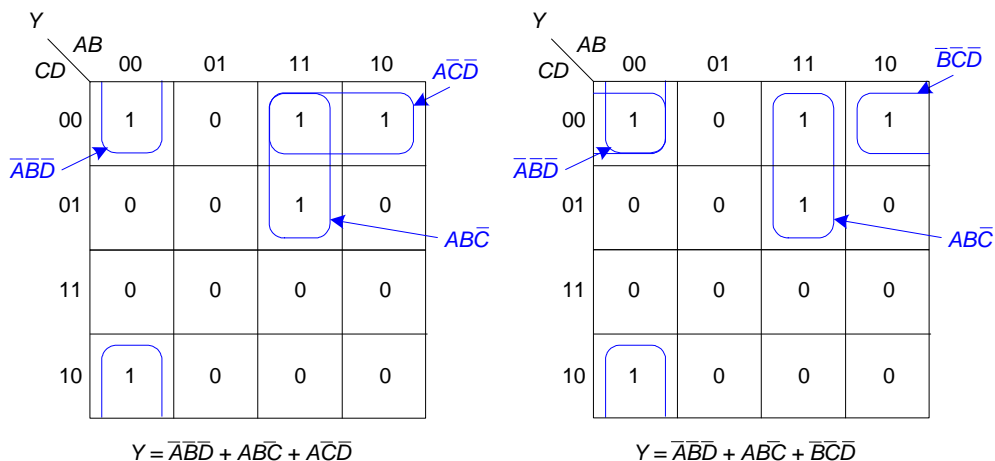

**Exercise 2.23**

$B_2$	$B_1$	$B_0$	$\overline{B_2} \cdot \overline{B_1} \cdot \overline{B_0}$	$\overline{B_2} + \overline{B_1} + \overline{B_0}$
0	0	0	1	1
0	0	1	1	1
0	1	0	1	1
0	1	1	1	1
1	0	0	1	1
1	0	1	1	1
1	1	0	1	1
1	1	1	0	0

**Exercise 2.25**

Y

	AB	00	01	11	10
CD	00	0	0	0	0
	01	1	1	1	1
	11	1	1	1	1
	10	0	0	0	1

*D* (arrow to row 01)

*A* $\bar{B}C (arrow to row 11)$

$\bar{A}$  $\bar{B}$ C (arrow to row 01)

$Y = \bar{A}\bar{B}C + D$

Z

	AB	00	01	11	10
CD	00	0	0	1	0
	01	0	1	1	1
	11	0	1	1	0
	10	0	0	0	0

*A* $\bar{C}$ *D* (arrow to cell 01, 11)

*B**D* (arrow to cell 11, 11)

$Z = \bar{A}\bar{C}D + BD$

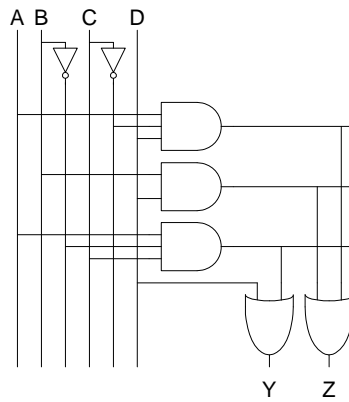

**Exercise 2.27**

---

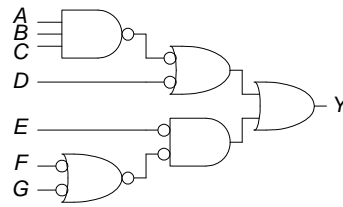

$$Y = ABC + \bar{D} + (\bar{F} + \bar{G})\bar{E}$$

$$= ABC + \bar{D} + \bar{E}\bar{F} + \bar{E}\bar{G}$$

**Exercise 2.29**

---

Two possible options are shown below:

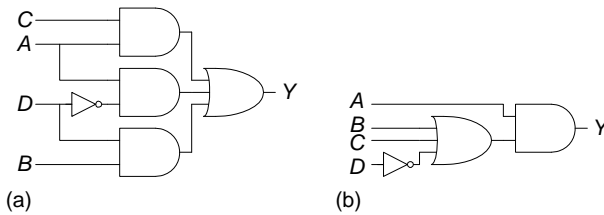

**Exercise 2.31**

---

$$Y = \bar{A}D + A\bar{B}\bar{C}\bar{D} + BD + CD = A\bar{B}\bar{C}\bar{D} + D(\bar{A} + B + C)$$

**Exercise 2.33**

---

The equation can be written directly from the description:

$$E = \bar{S}A + AL + H$$

**Exercise 2.35**

Decimal Value	$A_3$	$A_2$	$A_1$	$A_0$	$D$	$P$
0	0	0	0	0	0	0
1	0	0	0	1	0	0
2	0	0	1	0	0	1
3	0	0	1	1	1	1
4	0	1	0	0	0	0
5	0	1	0	1	0	1
6	0	1	1	0	1	0
7	0	1	1	1	0	1
8	1	0	0	0	0	0
9	1	0	0	1	1	0
10	1	0	1	0	0	0
11	1	0	1	1	0	1
12	1	1	0	0	1	0
13	1	1	0	1	0	1
14	1	1	1	0	0	0
15	1	1	1	1	1	0

$P$  has two possible minimal solutions:

$D$

$A_{3:2}$	00	01	11	10
00	0	0	1	0
01	0	0	0	1
11	1	0	1	0
10	0	1	0	0

$$D = \bar{A}_3 \bar{A}_2 A_1 A_0 + \bar{A}_3 A_2 A_1 \bar{A}_0 + A_3 \bar{A}_2 \bar{A}_1 A_0 + A_3 A_2 \bar{A}_1 \bar{A}_0 + A_3 A_2 A_1 A_0$$

$P$

$A_{3:2}$	00	01	11	10
00	0	0	0	0
01	0	1	1	0
11	1	1	0	1
10	1	0	0	0

$$P = \bar{A}_3 A_2 A_0 + \bar{A}_3 A_1 A_0 + \bar{A}_3 \bar{A}_2 A_1 + A_2 A_1 A_0$$

$$P = \bar{A}_3 A_1 A_0 + \bar{A}_3 \bar{A}_2 A_1 + \bar{A}_2 A_1 A_0 + A_2 \bar{A}_1 A_0$$

Hardware implementations are below (implementing the first minimal equation given for  $P$ ).

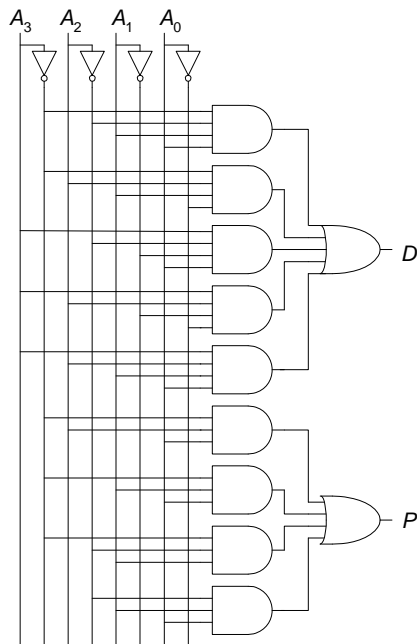

**Exercise 2.37**

The equations and circuit for  $Y_{2:0}$  is the same as in Exercise 2.25, repeated here for convenience.

$A_7$	$A_6$	$A_5$	$A_4$	$A_3$	$A_2$	$A_1$	$A_0$	$Y_2$	$Y_1$	$Y_0$
0	0	0	0	0	0	0	0	0	0	0
0	0	0	0	0	0	0	1	0	0	0
0	0	0	0	0	0	1	X	0	0	1
0	0	0	0	0	1	X	X	0	1	0
0	0	0	0	1	X	X	X	0	1	1
0	0	0	1	X	X	X	X	1	0	0
0	0	1	X	X	X	X	X	1	0	1
0	1	X	X	X	X	X	X	1	1	0
1	X	X	X	X	X	X	X	1	1	1

$$Y_2 = A_7 + A_6 + A_5 + A_4$$

$$Y_1 = A_7 + A_6 + \overline{A_5} \overline{A_4} A_3 + \overline{A_5} \overline{A_4} A_2$$

$$Y_0 = A_7 + \overline{A_6}A_5 + \overline{A_6}\overline{A_4}A_3 + \overline{A_6}\overline{A_4}\overline{A_2}A_1$$

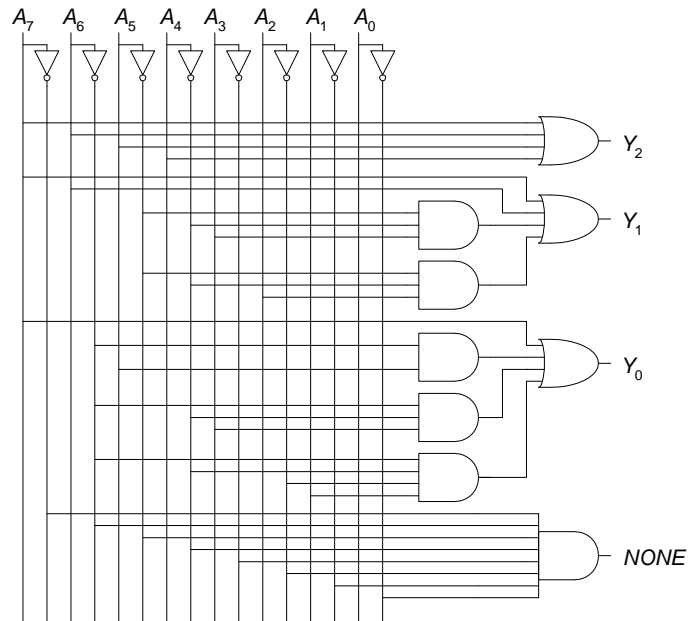

The truth table, equations, and circuit for  $Z_{2:0}$  are as follows.

$A_7$	$A_6$	$A_5$	$A_4$	$A_3$	$A_2$	$A_1$	$A_0$	$Z_2$	$Z_1$	$Z_0$
0	0	0	0	0	0	1	1	0	0	0
0	0	0	0	0	1	0	1	0	0	0
0	0	0	0	1	0	0	1	0	0	0
0	0	0	1	0	0	0	1	0	0	0
0	0	1	0	0	0	0	1	0	0	0
0	1	0	0	0	0	0	1	0	0	0
1	0	0	0	0	0	0	1	0	0	0
0	0	0	0	0	1	1	X	0	0	1
0	0	0	0	1	0	1	X	0	0	1
0	0	0	1	0	0	1	X	0	0	1
0	0	1	0	0	0	1	X	0	0	1
0	1	0	0	0	0	1	X	0	0	1
1	0	0	0	0	0	1	X	0	0	1
0	0	0	0	1	1	X	X	0	1	0
0	0	0	1	0	1	X	X	0	1	0
0	0	1	0	0	1	X	X	0	1	0
0	1	0	0	0	1	X	X	0	1	0
1	0	0	0	0	1	X	X	0	1	0
0	0	0	1	1	X	X	X	0	1	1
0	0	1	0	1	X	X	X	0	1	1
0	1	0	0	1	X	X	X	0	1	1
1	0	0	0	1	X	X	X	0	1	1
0	0	1	1	X	X	X	X	1	0	0
0	1	0	1	X	X	X	X	1	0	0
1	0	0	1	X	X	X	X	1	0	0
0	1	1	X	X	X	X	X	1	0	1
1	0	1	X	X	X	X	X	1	0	1
1	1	X	X	X	X	X	X	1	1	0

$$Z_2 = A_4(A_5 + A_6 + A_7) + A_5(A_6 + A_7) + A_6A_7$$

$$Z_1 = A_2(A_3 + A_4 + A_5 + A_6 + A_7) + A_3(A_4 + A_5 + A_6 + A_7) + A_6A_7$$

$$Z_0 = A_1(A_2 + A_3 + A_4 + A_5 + A_6 + A_7) + A_3(A_4 + A_5 + A_6 + A_7) + A_5(A_6 + A_7)$$

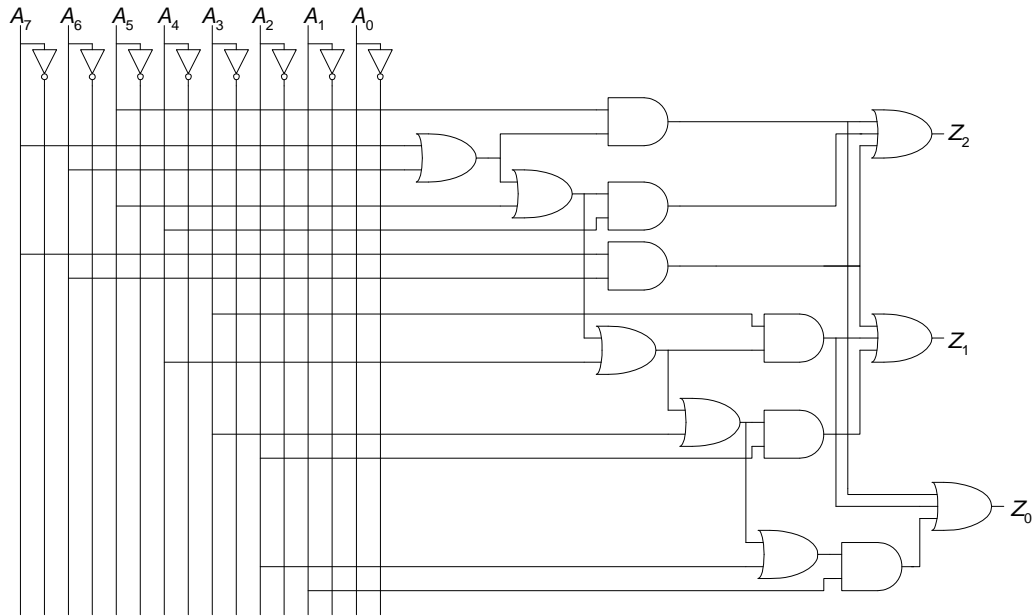

**Exercise 2.39**

$$Y = A + \overline{C \oplus D} = A + CD + \overline{C}\overline{D}$$

**Exercise 2.41**

A	B	C	Y
0	0	0	1
0	0	1	0
0	1	0	0
0	1	1	0
1	0	0	0
1	0	1	0
1	1	0	0
1	1	1	1

A	B	Y
0	0	$\overline{C}$
0	1	0
1	0	0
1	1	C

A	Y
0	$\overline{B}C$
1	BC

(a) (b) (c)



**Exercise 2.43**

---

$$t_{pd} = 3t_{pd\_NAND2} = \mathbf{60\ ps}$$

$$t_{cd} = t_{cd\_NAND2} = \mathbf{15\ ps}$$

**Exercise 2.45**

---

$$t_{pd} = t_{pd\_NOT} + t_{pd\_AND3}$$

$$= 15\ ps + 40\ ps$$

$$= \mathbf{55\ ps}$$

$$t_{cd} = t_{cd\_AND3}$$

$$= \mathbf{30\ ps}$$

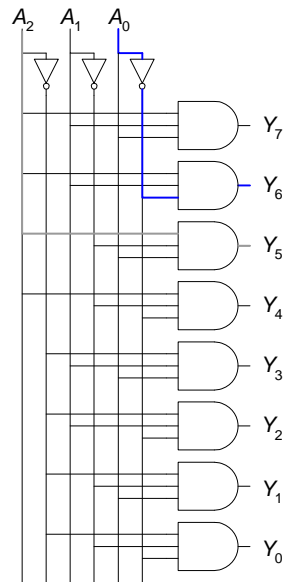

**Exercise 2.47**

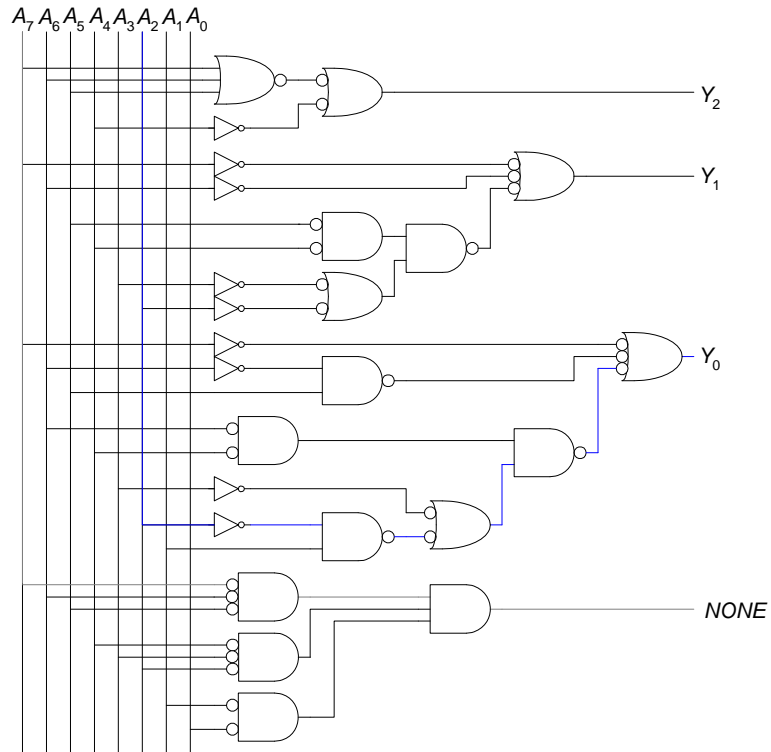

$$\begin{aligned}
 t_{pd} &= t_{pd\_INV} + 3t_{pd\_NAND2} + t_{pd\_NAND3} \\
 &= [15 + 3(20) + 30] \text{ ps} \\
 &= \mathbf{105 \text{ ps}}
 \end{aligned}$$

$$\begin{aligned}
 t_{cd} &= t_{cd\_NOT} + t_{cd\_NAND2} \\
 &= [10 + 15] \text{ ps} \\
 &= \mathbf{25 \text{ ps}}
 \end{aligned}$$

**Question 2.1**

---

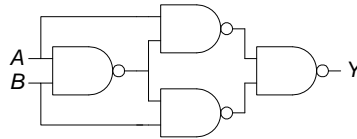

**Question 2.3**

---

A tristate buffer has two inputs and three possible outputs: 0, 1, and Z. One of the inputs is the data input and the other input is a control input, often called the *enable* input. When the enable input is 1, the tristate buffer transfers the data input to the output; otherwise, the output is high impedance, Z. Tristate buffers are used when multiple sources drive a single output at different times. One and only one tristate buffer is enabled at any given time.

**Question 2.5**

---

A circuit's contamination delay might be less than its propagation delay because the circuit may operate over a range of temperatures and supply voltages, for example, 3-3.6 V for LVCMOS (low voltage CMOS) chips. As temperature increases and voltage decreases, circuit delay increases. Also, the circuit may have different paths (critical and short paths) from the input to the output. A gate itself may have varying delays between different inputs and the output, affecting the gate's critical and short paths. For example, for a two-input NAND gate, a HIGH to LOW transition requires two nMOS transistor delays, whereas a LOW to HIGH transition requires a single pMOS transistor delay.

# CHAPTER 3

## Exercise 3.1

---

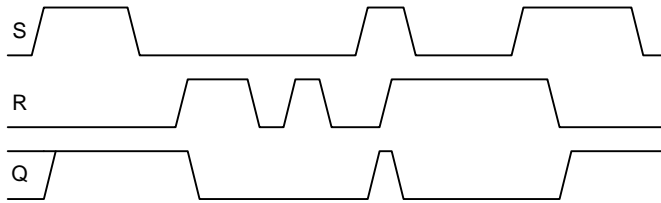

## Exercise 3.3

---

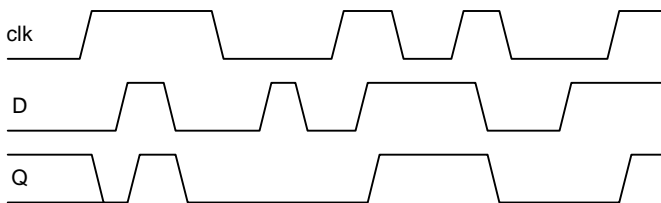

**Exercise 3.5**

---

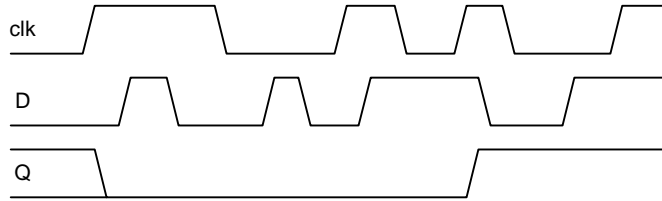

**Exercise 3.7**

---

The circuit is sequential because it involves feedback and the output depends on previous values of the inputs. This is a SR latch. When  $\bar{S} = 0$  and  $\bar{R} = 1$ , the circuit sets  $Q$  to 1. When  $\bar{S} = 1$  and  $\bar{R} = 0$ , the circuit resets  $Q$  to 0. When both  $\bar{S}$  and  $\bar{R}$  are 1, the circuit remembers the old value. And when both  $\bar{S}$  and  $\bar{R}$  are 0, the circuit drives both outputs to 1.

**Exercise 3.9**

---

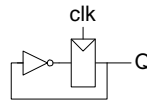

**Exercise 3.11**

---

If  $A$  and  $B$  have the same value,  $C$  takes on that value. Otherwise,  $C$  retains its old value.

**Exercise 3.13**

---

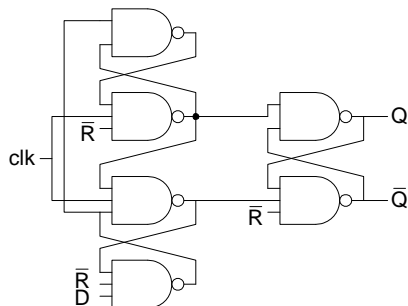

**Exercise 3.15**

---

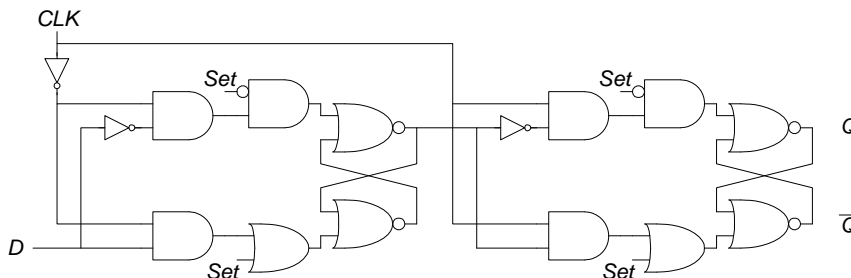

**Exercise 3.17**

---

If  $N$  is even, the circuit is stable and will not oscillate.

**Exercise 3.19**

---

The system has at least five bits of state to represent the 24 floors that the elevator might be on.

**Exercise 3.21**

---

The FSM could be factored into four independent state machines, one for each student. Each of these machines has five states and requires 3 bits, so at least 12 bits of state are required for the factored design.

**Exercise 3.23**

This finite state machine asserts the output  $Q$  when  $A$  AND  $B$  is TRUE.

state	encoding $s_{1:0}$
S0	00
S1	01
S2	10

TABLE 3.1 State encoding for Exercise 3.23

current state		inputs		next state		output
$s_1$	$s_0$	$a$	$b$	$s'_1$	$s'_0$	$q$
0	0	0	X	0	0	0
0	0	1	X	0	1	0
0	1	X	0	0	0	0
0	1	X	1	1	0	0
1	0	1	1	1	0	1
1	0	0	0	0	0	0
1	0	0	1	0	0	0
1	0	1	0	0	0	0

TABLE 3.2 Combined state transition and output table with binary encodings for Exercise 3.23

$$S'_1 = \overline{S_1}S_0B + S_1AB$$

$$S'_0 = \overline{S_1}\overline{S_0}A$$

$$Q' = S_1AB$$

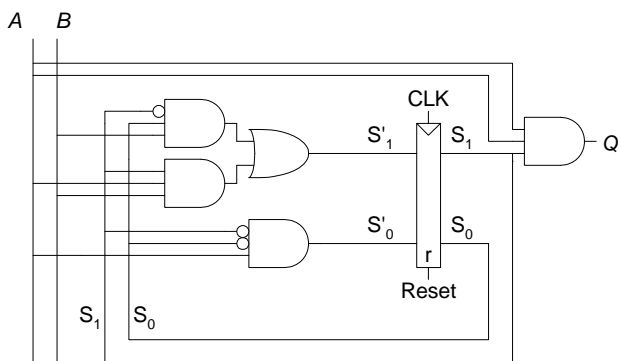

**Exercise 3.25**

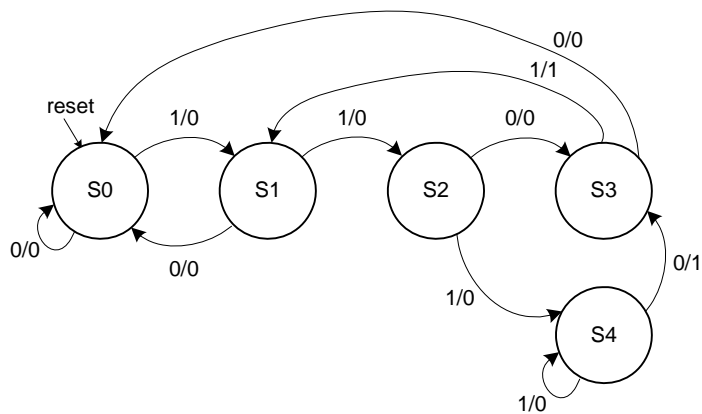

state	encoding $s_1:0$
S0	000
S1	001

**TABLE 3.3** State encoding for Exercise 3.25



state	encoding $s_{1:0}$
S2	010
S3	100
S4	101

TABLE 3.3 State encoding for Exercise 3.25

current state			input	next state			output
$s_2$	$s_1$	$s_0$	$a$	$s'_2$	$s'_1$	$s'_0$	$q$
0	0	0	0	0	0	0	0
0	0	0	1	0	0	1	0
0	0	1	0	0	0	0	0
0	0	1	1	0	1	0	0
0	1	0	0	1	0	0	0
0	1	0	1	1	0	1	0
1	0	0	0	0	0	0	0
1	0	0	1	0	0	1	1
1	0	1	0	1	0	0	1
1	0	1	1	1	0	1	0

TABLE 3.4 Combined state transition and output table with binary encodings for Exercise 3.25

$$S'_2 = \overline{S}_2 \overline{S}_1 \overline{S}_0 + S_2 \overline{S}_1 S_0$$

$$S'_1 = \overline{S}_2 \overline{S}_1 S_0 A$$

$$S'_0 = A(\overline{S}_2 \overline{S}_0 + S_2 \overline{S}_1)$$

$$Q = S_2 \overline{S}_1 \overline{S}_0 A + S_2 \overline{S}_1 S_0 \overline{A}$$

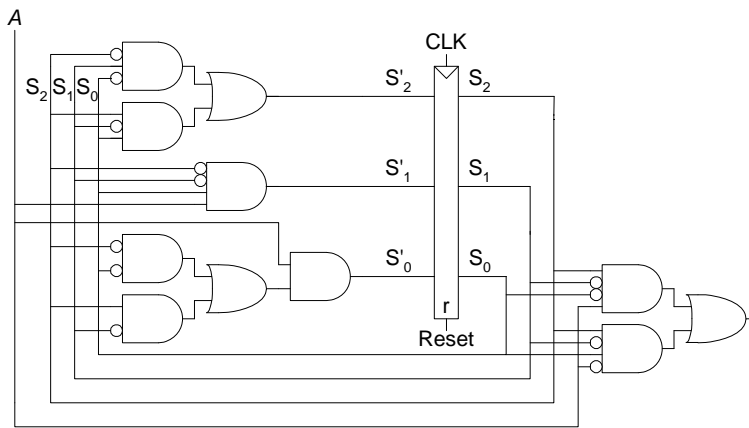

**Exercise 3.27**

---

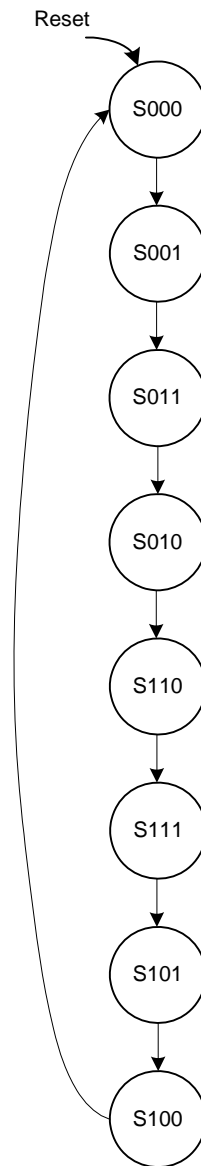

FIGURE 3.1 State transition diagram for Exercise 3.27

current state $s_{2:0}$	next state $s'_{2:0}$
000	001
001	011
011	010
010	110
110	111
111	101
101	100
100	000

TABLE 3.5 State transition table for Exercise 3.27

$$S'_2 = S_1 \overline{S_0} + S_2 S_0$$

$$S'_1 = \overline{S_2} S_0 + S_1 \overline{S_0}$$

$$S'_0 = \overline{S_2} \oplus S_1$$

$$Q_2 = S_2$$

$$Q_1 = S_1$$

$$Q_0 = S_0$$

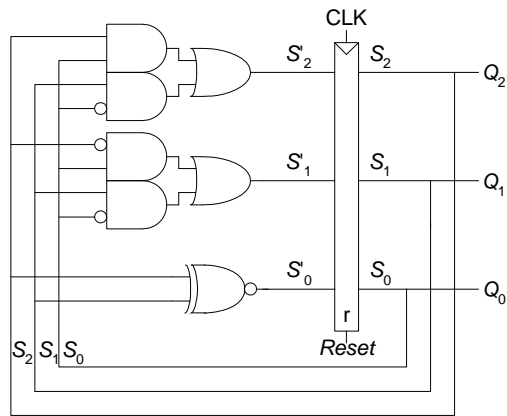

FIGURE 3.2 Hardware for Gray code counter FSM for Exercise 3.27

**Exercise 3.29**

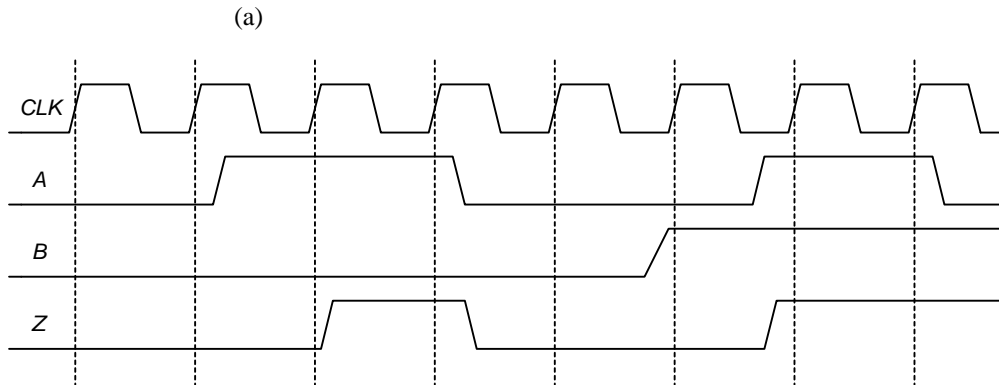

FIGURE 3.3 Waveform showing Z output for Exercise 3.29

(b) This FSM is a Mealy FSM because the output depends on the current value of the input as well as the current state.

(c)

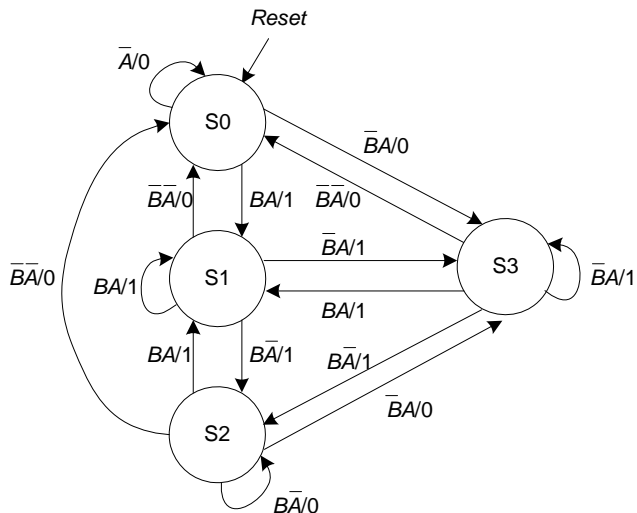

FIGURE 3.4 State transition diagram for Exercise 3.29

(Note: another viable solution would be to allow the state to transition from S0 to S1 on  $\overline{BA}/0$ . The arrow from S0 to S0 would then be  $\overline{BA}/0$ .)

current state $s_{1:0}$	inputs		next state $s'_{1:0}$	output $z$
	$b$	$a$		
00	X	0	00	0
00	0	1	11	0
00	1	1	01	1
01	0	0	00	0
01	0	1	11	1
01	1	0	10	1
01	1	1	01	1
10	0	X	00	0
10	1	0	10	0

TABLE 3.6 State transition table for Exercise 3.29

current state $s_{1:0}$	inputs		next state $s'_{1:0}$	output $z$
	$b$	$a$		
10	1	1	01	1
11	0	0	00	0
11	0	1	11	1
11	1	0	10	1
11	1	1	01	1

TABLE 3.6 State transition table for Exercise 3.29

$$S'_1 = \bar{B}A(\bar{S}_1 + S_0) + B\bar{A}(S_1 + \bar{S}_0)$$

$$S'_0 = A(\bar{S}_1 + S_0 + B)$$

$$Z = BA + S_0(A + B)$$

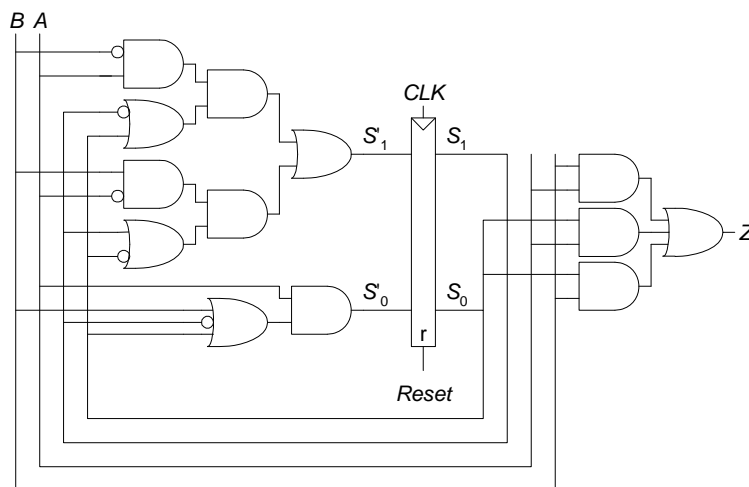

FIGURE 3.5 Hardware for FSM of Exercise 3.26

**Note:** One could also build this functionality by registering input A, producing both the logical AND and OR of input A and its previous (registered)

value, and then muxing the two operations using  $B$ . The output of the mux is  $Z$ :  $Z = A \text{Aprev}$  (if  $B = 0$ );  $Z = A + A \text{prev}$  (if  $B = 1$ ).

**Exercise 3.31**

---

This finite state machine is a divide-by-two counter (see Section 3.4.2) when  $X = 0$ . When  $X = 1$ , the output,  $Q$ , is HIGH.

current state		input	next state	
$s_1$	$s_0$	$x$	$s'_1$	$s'_0$
0	0	0	0	1
0	0	1	1	1
0	1	0	0	0
0	1	1	1	0
1	X	X	0	1

TABLE 3.7 State transition table with binary encodings for Exercise 3.31

current state		output
$s_1$	$s_0$	$q$
0	0	0
0	1	1
1	X	1

TABLE 3.8 Output table for Exercise 3.31



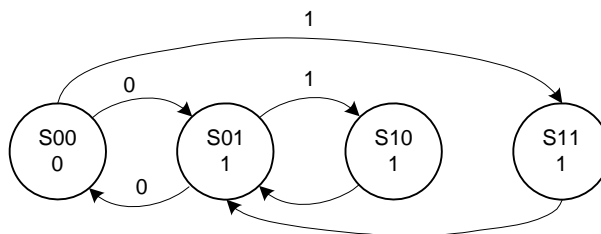

**Exercise 3.33**

(a) First, we calculate the propagation delay through the combinational logic:

$$\begin{aligned}
 t_{pd} &= 3t_{pd\_XOR} \\
 &= 3 \times 100 \text{ ps} \\
 &= \mathbf{300 \text{ ps}}
 \end{aligned}$$

Next, we calculate the cycle time:

$$\begin{aligned}
 T_c &\geq t_{pcq} + t_{pd} + t_{setup} \\
 &\geq [70 + 300 + 60] \text{ ps} \\
 &= 430 \text{ ps}
 \end{aligned}$$

$$f = 1 / 430 \text{ ps} = \mathbf{2.33 \text{ GHz}}$$

(b)

$$T_c \geq t_{pcq} + t_{pd} + t_{setup} + t_{skew}$$

Thus,

$$\begin{aligned}
 t_{skew} &\leq T_c - (t_{pcq} + t_{pd} + t_{setup}), \text{ where } T_c = 1 / 2 \text{ GHz} = 500 \text{ ps} \\
 &\leq [500 - 430] \text{ ps} = \mathbf{70 \text{ ps}}
 \end{aligned}$$

(c)

First, we calculate the contamination delay through the combinational logic:

$$\begin{aligned}
 t_{cd} &= t_{cd\_XOR} \\
 &= 55 \text{ ps}
 \end{aligned}$$

$$t_{ccq} + t_{cd} > t_{hold} + t_{skew}$$

Thus,

$$\begin{aligned}
 t_{skew} &< (t_{ccq} + t_{cd}) - t_{hold} \\
 &< (50 + 55) - 20 \\
 &< \mathbf{85 \text{ ps}}
 \end{aligned}$$

(d)

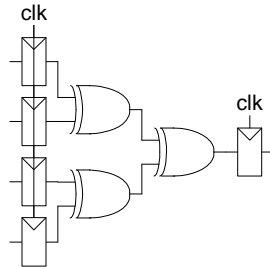

FIGURE 3.6 Alyssa's improved circuit for Exercise 3.33

First, we calculate the propagation and contamination delays through the combinational logic:

$$\begin{aligned} t_{pd} &= 2t_{pd\_XOR} \\ &= 2 \times 100 \text{ ps} \\ &= \mathbf{200 \text{ ps}} \end{aligned}$$

$$\begin{aligned} t_{cd} &= 2t_{cd\_XOR} \\ &= 2 \times 55 \text{ ps} \\ &= \mathbf{110 \text{ ps}} \end{aligned}$$

Next, we calculate the cycle time:

$$\begin{aligned} T_c &\geq t_{pcq} + t_{pd} + t_{setup} \\ &\geq [70 + 200 + 60] \text{ ps} \\ &= 330 \text{ ps} \end{aligned}$$

$$f = 1 / 330 \text{ ps} = \mathbf{3.03 \text{ GHz}}$$

$$\begin{aligned} t_{skew} &< (t_{ccq} + t_{cd}) - t_{hold} \\ &< (50 + 110) - 20 \\ &< \mathbf{140 \text{ ps}} \end{aligned}$$

### Exercise 3.35

---

(a)  $T_c = 1 / 40 \text{ MHz} = 25 \text{ ns}$

$$\begin{aligned} T_c &\geq t_{pcq} + Nt_{CLB} + t_{setup} \\ 25 \text{ ns} &\geq [0.72 + N(0.61) + 0.53] \text{ ps} \end{aligned}$$

Thus,  $N < 38.9$

**N = 38**

(b)

$$\begin{aligned}
 t_{\text{skew}} &< (t_{\text{ccq}} + t_{\text{cd\_CLB}}) - t_{\text{hold}} \\
 &< [(0.5 + 0.3) - 0] \text{ ns} \\
 &< \mathbf{0.8 \text{ ns} = 800 \text{ ps}}
 \end{aligned}$$

**Exercise 3.37**

---

$$P(\text{failure})/\text{sec} = 1/\text{MTBF} = 1/(50 \text{ years} * 3.15 * 10^7 \text{ sec/year}) = \mathbf{6.34 * 10^{-10}} \quad (\text{EQ 3.26})$$

$$\begin{aligned}
 P(\text{failure})/\text{sec} \text{ waiting for one clock cycle: } &N * (T_0/T_c) * e^{-(T_c - t_{\text{setup}})/\text{Tau}} \\
 &= 0.5 * (110/1000) * e^{-(1000-70)/100} = 5.0 * 10^{-6}
 \end{aligned}$$

$$\begin{aligned}
 P(\text{failure})/\text{sec} \text{ waiting for two clock cycles: } &N * (T_0/T_c) * [e^{-(T_c - t_{\text{setup}})/\text{Tau}}]^2 \\
 &= 0.5 * (110/1000) * [e^{-(1000-70)/100}]^2 = 4.6 * 10^{-10}
 \end{aligned}$$

This is just less than the required probability of failure ( $6.34 * 10^{-10}$ ). Thus, **2 cycles** of waiting is just adequate to meet the MTBF.

**Exercise 3.39**

---

We assume a two flip-flop synchronizer. The most significant impact on the probability of failure comes from the exponential component. If we ignore the  $T_0/T_c$  term in the probability of failure equation, assuming it changes little with increases in cycle time, we get:

$$\begin{aligned}
 P(\text{failure}) &= e^{-\frac{t}{\tau}} \\
 \text{MTBF} &= \frac{1}{P(\text{failure})} = e^{\frac{T_c - t_{\text{setup}}}{\tau}} \\
 \frac{\text{MTBF}_2}{\text{MTBF}_1} &= 10 = e^{\frac{T_{c2} - T_{c1}}{30 \text{ ps}}}
 \end{aligned}$$

Solving for  $T_{c2} - T_{c1}$ , we get:

$$T_{c2} - T_{c1} = 69 \text{ ps}$$

Thus, the clock cycle time must increase by **69 ps**. This holds true for cycle times much larger than  $T_0$  (20 ps) and the increased time (69 ps).

**Question 3.1**

---

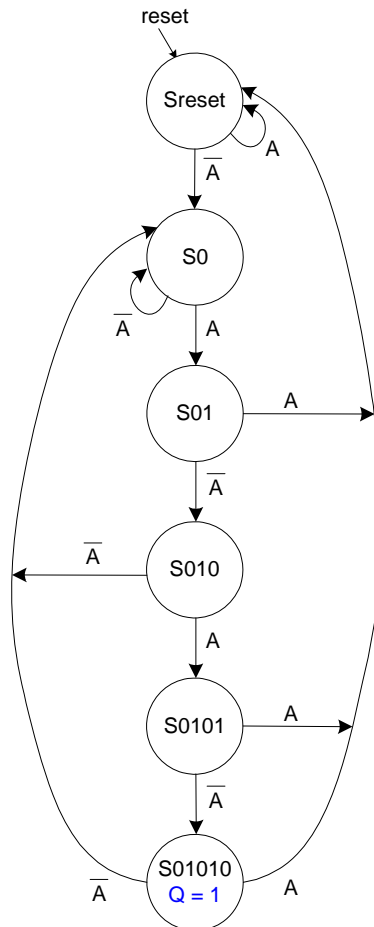

FIGURE 3.7 State transition diagram for Question 3.1

current state $s_{5:0}$	input	next state $s'_{5:0}$
	$a$	
000001	0	000010
000001	1	000001
000010	0	000010
000010	1	000100
000100	0	001000
000100	1	000001
001000	0	000010
001000	1	010000
010000	0	100000
010000	1	000001
100000	0	000010
100000	1	000001

TABLE 3.9 State transition table for Question 3.1

$$S'_5 = S_4A$$

$$S'_4 = S_3A$$

$$S'_3 = S_2A$$

$$S'_2 = S_1A$$

$$S'_1 = A(S_1 + S_3 + S_5)$$

$$S'_0 = A(S_0 + S_2 + S_4 + S_5)$$

$$Q = S_5$$

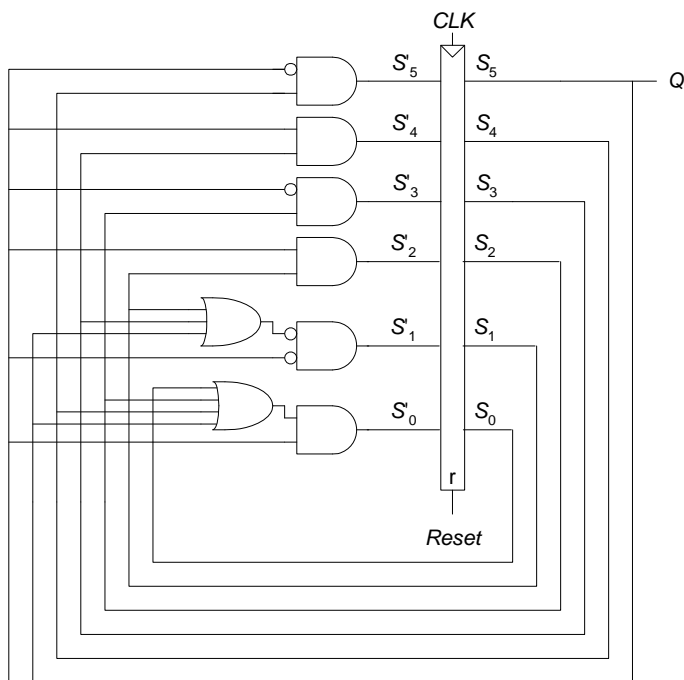
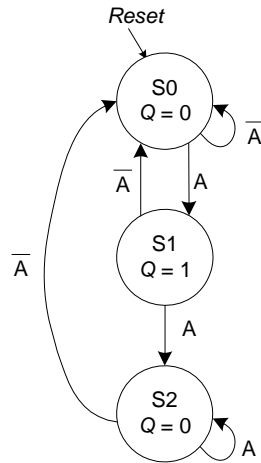

FIGURE 3.8 Finite state machine hardware for Question 3.1

### Question 3.3

A latch allows input  $D$  to flow through to the output  $Q$  when the clock is HIGH. A flip-flop allows input  $D$  to flow through to the output  $Q$  at the clock edge. A flip-flop is preferable in systems with a single clock. Latches are preferable in *two-phase clocking* systems, with two clocks. The two clocks are used to eliminate system failure due to hold time violations. Both the phase and frequency of each clock can be modified independently.

**Question 3.5**



**FIGURE 3.9** State transition diagram for edge detector circuit of Question 3.5

current state $s_{1:0}$	input	next state $s'_{1:0}$
	$a$	
00	0	00
00	1	01
01	0	00
01	1	10
10	0	00
10	1	10

**TABLE 3.10** State transition table for Question 3.5

$$S'_1 = AS_1$$

$$S'_0 = AS_1S_0$$

$$Q = S_1$$

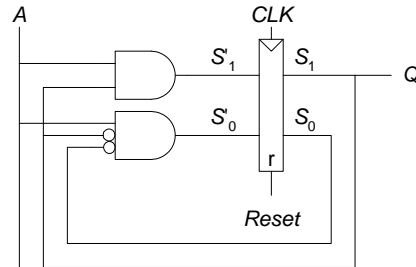

FIGURE 3.10 Finite state machine hardware for Question 3.5

### Question 3.7

---

A flip-flop with a negative hold time allows  $D$  to start changing *before* the clock edge arrives.

### Question 3.9

---

Without the added buffer, the propagation delay through the logic,  $t_{pd}$ , must be less than or equal to  $T_c - (t_{pcq} + t_{setup})$ . However, if you add a buffer to the clock input of the receiver, the clock arrives at the receiver later. The earliest that the clock edge arrives at the receiver is  $t_{cd\_BUF}$  after the actual clock edge. Thus, the propagation delay through the logic is now given an extra  $t_{cd\_BUF}$ . So,  $t_{pd}$  now must be less than  $T_c + t_{cd\_BUF} - (t_{pcq} + t_{setup})$ .



# CHAPTER 4

**Note:** the HDL files given in the following solutions are available on the textbook's companion website at:

<http://textbooks.elsevier.com/9780123704979>

## Exercise 4.1

---

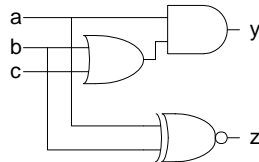

### Exercise 4.3

---

#### SystemVerilog

```
module xor_4(input logic [3:0] a,  
            output logic y);  
  
    assign y = ^a;  
endmodule
```

#### VHDL

```
library IEEE; use IEEE.STD_LOGIC_1164.all;  
  
entity xor_4 is  
    port(a: in STD_LOGIC_VECTOR(3 downto 0);  
         y: out STD_LOGIC);  
end;  
  
architecture synth of xor_4 is  
begin  
    y <= a(3) xor a(2) xor a(1) xor a(0);  
end;
```

### Exercise 4.5

---

#### SystemVerilog

```
module minority(input logic a, b, c  
               output logic y);  
  
    assign y = ~a & ~b | ~a & ~c | ~b & ~c;  
endmodule
```

#### VHDL

```
library IEEE; use IEEE.STD_LOGIC_1164.all;  
  
entity minority is  
    port(a, b, c: in STD_LOGIC;  
         y: out STD_LOGIC);  
end;  
  
architecture synth of minority is  
begin  
    y <= ((not a) and (not b)) or ((not a) and (not c))  
        or ((not b) and (not c));  
end;
```

### Exercise 4.7

---

ex4\_7.tv file:

```
0000_111_1110  
0001_011_0000  
0010_110_1101  
0011_111_1001  
0100_011_0011  
0101_101_1011  
0110_101_1111  
0111_111_0000  
1000_111_1111  
1001_111_1011  
1010_111_0111  
1011_001_1111  
1100_000_1101  
1101_011_1101  
1110_100_1111  
1111_100_0111
```

## Option 1:

## SystemVerilog

```

module ex4_7_testbench();
    logic        clk, reset;
    logic [3:0]  data;
    logic [6:0]  s_expected;
    logic [6:0]  s;
    logic [31:0] vectornum, errors;
    logic [10:0] testvectors[10000:0];

    // instantiate device under test
    sevenseg dut(data, s);

    // generate clock
    always
    begin
        clk = 1; #5; clk = 0; #5;
    end

    // at start of test, load vectors
    // and pulse reset
    initial
    begin
        $readmemb("ex4_7.tv", testvectors);
        vectornum = 0; errors = 0;
        reset = 1; #27; reset = 0;
    end

    // apply test vectors on rising edge of clk
    always @(posedge clk)
    begin
        #1; {data, s_expected} =
            testvectors[vectornum];
    end

    // check results on falling edge of clk
    always @(negedge clk)
    if (~reset) begin // skip during reset
        if (s != s_expected) begin
            $display("Error: inputs = %h", data);
            $display("  outputs = %b (%b expected)",
                s, s_expected);
            errors = errors + 1;
        end
        vectornum = vectornum + 1;
        if (testvectors[vectornum] == 11'bx) begin
            $display("%d tests completed with %d errors",
                vectornum, errors);
            $finish;
        end
    end
endmodule

```

## VHDL

```

library IEEE; use IEEE.STD_LOGIC_1164.all;
use STD.TEXTIO.all;
use IEEE.STD_LOGIC_UNSIGNED.all;
use IEEE.STD_LOGIC_ARITH.all;

entity ex4_7_testbench is -- no inputs or outputs
end;

architecture sim of ex4_7_testbench is
    component seven_seg_decoder
        port(data:    in STD_LOGIC_VECTOR(3 downto 0);
             segments: out STD_LOGIC_VECTOR(6 downto 0));
    end component;
    signal data: STD_LOGIC_VECTOR(3 downto 0);
    signal s:    STD_LOGIC_VECTOR(6 downto 0);
    signal clk, reset: STD_LOGIC;
    signal s_expected: STD_LOGIC_VECTOR(6 downto 0);
    constant MEMSIZE: integer := 10000;
    type tarray is array(MEMSIZE downto 0) of
        STD_LOGIC_VECTOR(10 downto 0);
    signal testvectors: tarray;
    shared variable vectornum, errors: integer;
begin
    -- instantiate device under test
    dut: seven_seg_decoder port map(data, s);

    -- generate clock
    process begin
        clk <= '1'; wait for 5 ns;
        clk <= '0'; wait for 5 ns;
    end process;

    -- at start of test, load vectors
    -- and pulse reset
    process is
        file tv: TEXT;
        variable i, j: integer;
        variable L: line;
        variable ch: character;
    begin
        -- read file of test vectors
        i := 0;
        FILE_OPEN(tv, "ex4_7.tv", READ_MODE);
        while not endfile(tv) loop
            readline(tv, L);
            for j in 10 downto 0 loop
                read(L, ch);
                if (ch = '_') then read(L, ch);
                end if;
                if (ch = '0') then
                    testvectors(i)(j) <= '0';
                else testvectors(i)(j) <= '1';
                end if;
            end loop;
            i := i + 1;
        end loop;
    end process;
end architecture;

```

(VHDL continued on next page)

*(continued from previous page)*

## VHDL

```
vectornum := 0; errors := 0;
reset <= '1'; wait for 27 ns; reset <= '0';
wait;
end process;

-- apply test vectors on rising edge of clk
process (clk) begin
  if (clk'event and clk = '1') then

    data <= testvectors(vectornum)(10 downto 7)
      after 1 ns;
    s_expected <= testvectors(vectornum)(6 downto 0)
      after 1 ns;
    end if;
end process;

-- check results on falling edge of clk
process (clk) begin
  if (clk'event and clk = '0' and reset = '0') then
    assert s = s_expected
      report "data = " &
        integer'image(CONV_INTEGER(data)) &
        "; s = " &
        integer'image(CONV_INTEGER(s)) &
        "; s_expected = " &
        integer'image(CONV_INTEGER(s_expected));
    if (s /= s_expected) then
      errors := errors + 1;
    end if;
    vectornum := vectornum + 1;
    if (is_x(testvectors(vectornum))) then
      if (errors = 0) then
        report "Just kidding -- " &
          integer'image(vectornum) &
          " tests completed successfully."
          severity failure;
      else
        report integer'image(vectornum) &
          " tests completed, errors = " &
          integer'image(errors)
          severity failure;
      end if;
    end if;
  end process;
end;
```

## Option 2 (VHDL only):

## VHDL

```

library IEEE; use IEEE.STD_LOGIC_1164.all;
use STD.TEXTIO.all;
use work.txt_util.all;

entity ex4_7_testbench is -- no inputs or outputs
end;

architecture sim of ex4_7_testbench is
  component seven_seg_decoder
    port(data:      in  STD_LOGIC_VECTOR(3 downto 0);
          segments: out STD_LOGIC_VECTOR(6 downto 0));
  end component;
  signal data: STD_LOGIC_VECTOR(3 downto 0);
  signal s:    STD_LOGIC_VECTOR(6 downto 0);
  signal clk, reset: STD_LOGIC;
  signal s_expected: STD_LOGIC_VECTOR(6 downto 0);
  constant MEMSIZE: integer := 10000;
  type tarray is array(MEMSIZE downto 0) of
    STD_LOGIC_VECTOR(10 downto 0);
  signal testvectors: tarray;
  shared variable vectornum, errors: integer;
begin
  -- instantiate device under test
  dut: seven_seg_decoder port map(data, s);

  -- generate clock
  process begin
    clk <= '1'; wait for 5 ns;
    clk <= '0'; wait for 5 ns;
  end process;

  -- at start of test, load vectors
  -- and pulse reset
  process is
    file tv: TEXT;
    variable i, j: integer;
    variable L: line;
    variable ch: character;
  begin
    -- read file of test vectors
    i := 0;
    FILE_OPEN(tv, "ex4_7.tv", READ_MODE);
    while not endfile(tv) loop
      readline(tv, L);
      for j in 10 downto 0 loop
        read(L, ch);
        if (ch = '_') then read(L, ch);
        end if;
        if (ch = '0') then
          testvectors(i)(j) <= '0';
        else testvectors(i)(j) <= '1';
        end if;
      end loop;
      i := i + 1;
    end loop;

    vectornum := 0; errors := 0;
    reset <= '1'; wait for 27 ns; reset <= '0';

    wait;
  end process;

  -- apply test vectors on rising edge of clk
  process (clk) begin
    if (clk'event and clk = '1') then
      data <= testvectors(vectornum)(10 downto 7)
        after 1 ns;
      s_expected <= testvectors(vectornum)(6 downto 0)
        after 1 ns;
    end if;
  end process;

  -- check results on falling edge of clk
  process (clk) begin
    if (clk'event and clk = '0' and reset = '0') then
      assert s = s_expected
        report "data = " & str(data) &
          "; s = " & str(s) &
            "; s_expected = " & str(s_expected);
      if (s /= s_expected) then
        errors := errors + 1;
      end if;
      vectornum := vectornum + 1;
      if (is_x(testvectors(vectornum))) then
        if (errors = 0) then
          report "Just kidding -- " &
            integer'image(vectornum) &
              " tests completed successfully."
            severity failure;
        else
          report integer'image(vectornum) &
            " tests completed, errors = " &
              integer'image(errors)
            severity failure;
        end if;
      end if;
    end process;
  end;
end;

```

(see Web site for file: txt\_util.vhd)

### Exercise 4.9

---

#### SystemVerilog

```
module ex4_9
  (input logic a, b, c,
   output logic y);

  mux8 #(1) mux8_1(1'b1, 1'b0, 1'b0, 1'b1,
                  1'b1, 1'b1, 1'b0, 1'b0,
                  {a,b,c}, y);

endmodule
```

#### VHDL

```
library IEEE; use IEEE.STD_LOGIC_1164.all;

entity ex4_9 is
  port(a,
        b,
        c: in STD_LOGIC;
        y: out STD_LOGIC_VECTOR(0 downto 0));
end;

architecture struct of ex4_9 is
  component mux8
    generic(width: integer);
    port(d0, d1, d2, d3, d4, d5, d6,
          d7: in STD_LOGIC_VECTOR(width-1 downto 0);
          s: in STD_LOGIC_VECTOR(2 downto 0);
          y: out STD_LOGIC_VECTOR(width-1 downto 0));
  end component;
  signal sel: STD_LOGIC_VECTOR(2 downto 0);
begin
  sel <= a & b & c;

  mux8_1: mux8 generic map(1)
    port map("1", "0", "0", "1",
             "1", "1", "0", "0",
             sel, y);
end;
```

### Exercise 4.11

---

A shift register with feedback, shown below, cannot be correctly described with blocking assignments.

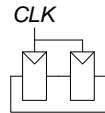

### Exercise 4.13

---

#### SystemVerilog

```

module decoder2_4(input  logic [1:0] a,
                 output logic [3:0] y);
    always_comb
        case (a)
            2'b00: y = 4'b0001;
            2'b01: y = 4'b0010;
            2'b10: y = 4'b0100;
            2'b11: y = 4'b1000;
        endcase
endmodule

```

#### VHDL

```

library IEEE; use IEEE.STD_LOGIC_1164.all;

entity decoder2_4 is
    port(a: in  STD_LOGIC_VECTOR(1 downto 0);
         y: out STD_LOGIC_VECTOR(3 downto 0));
end;

architecture synth of decoder2_4 is
begin
    process(all) begin
        case a is
            when "00" => y <= "0001";
            when "01" => y <= "0010";
            when "10" => y <= "0100";
            when "11" => y <= "1000";
            when others => y <= "0000";
        end case;
    end process;
end;

```

**Exercise 4.15**

---

(a)  $Y = AC + \overline{A}\overline{B}C$

**SystemVerilog**

```
module ex4_15a(input logic a, b, c,
              output logic y);
    assign y = (a & c) | (~a & ~b & c);
endmodule
```

**VHDL**

```
library IEEE; use IEEE.STD_LOGIC_1164.all;
entity ex4_15a is
    port(a, b, c: in STD_LOGIC;
         y: out STD_LOGIC);
end;
architecture behave of ex4_15a is
begin
    y <= (not a and not b and c) or (not b and c);
end;
```

(b)  $Y = \overline{A}\overline{B} + \overline{A}B\overline{C} + \overline{\overline{A + C}}$

**SystemVerilog**

```
module ex4_15b(input logic a, b, c,
              output logic y);
    assign y = (~a & ~b) | (~a & b & ~c) | ~(a | ~c);
endmodule
```

**VHDL**

```
library IEEE; use IEEE.STD_LOGIC_1164.all;
entity ex4_15b is
    port(a, b, c: in STD_LOGIC;
         y: out STD_LOGIC);
end;
architecture behave of ex4_15b is
begin
    y <= ((not a) and (not b)) or ((not a) and b and
    (not c)) or (not(a or (not c)));
end;
```

(c)  $Y = \overline{A}\overline{B}\overline{C}\overline{D} + \overline{A}\overline{B}C + \overline{A}B\overline{C}\overline{D} + ABD + \overline{A}\overline{B}C\overline{D} + \overline{B}\overline{C}\overline{D} + \overline{A}$

**SystemVerilog**

```
module ex4_15c(input logic a, b, c, d,
              output logic y);
    assign y = (~a & ~b & ~c & ~d) | (a & ~b & ~c) |
    (a & ~b & c & ~d) | (a & b & d) |
    (~a & ~b & c & ~d) | (b & ~c & d) | ~a;
endmodule
```

**VHDL**

```
library IEEE; use IEEE.STD_LOGIC_1164.all;
entity ex4_15c is
    port(a, b, c, d: in STD_LOGIC;
         y: out STD_LOGIC);
end;
architecture behave of ex4_15c is
begin
    y <= ((not a) and (not b) and (not c) and (not d)) or
    (a and (not b) and (not c)) or
    (a and (not b) and c and (not d)) or
    (a and b and d) or
    ((not a) and (not b) and c and (not d)) or
    (b and (not c) and d) or (not a);
end;
```



### Exercise 4.17

---

#### SystemVerilog

```
module ex4_17(input logic a, b, c, d, e, f, g
             output logic y);

    logic n1, n2, n3, n4, n5;

    assign n1 = ~(a & b & c);
    assign n2 = ~(n1 & d);
    assign n3 = ~(f & g);
    assign n4 = ~(n3 | e);
    assign n5 = ~(n2 | n4);
    assign y = ~(n5 & n5);
endmodule
```

#### VHDL

```
library IEEE; use IEEE.STD_LOGIC_1164.all;

entity ex4_17 is
    port(a, b, c, d, e, f, g: in STD_LOGIC;
         y: out STD_LOGIC);
end;

architecture synth of ex4_17 is
    signal n1, n2, n3, n4, n5: STD_LOGIC;
begin
    n1 <= not(a and b and c);
    n2 <= not(n1 and d);
    n3 <= not(f and g);
    n4 <= not(n3 or e);
    n5 <= not(n2 or n4);
    y <= not (n5 or n5);
end;
```

### Exercise 4.19

---

## SystemVerilog

```
module ex4_18(input logic [3:0] a,  
             output logic p, d);  
  
    always_comb  
    case (a)  
        0: {p, d} = 2'b00;  
        1: {p, d} = 2'b00;  
        2: {p, d} = 2'b10;  
        3: {p, d} = 2'b11;  
        4: {p, d} = 2'b00;  
        5: {p, d} = 2'b10;  
        6: {p, d} = 2'b01;  
        7: {p, d} = 2'b10;  
        8: {p, d} = 2'b00;  
        9: {p, d} = 2'b01;  
        10: {p, d} = 2'b00;  
        11: {p, d} = 2'b10;  
        12: {p, d} = 2'b01;  
        13: {p, d} = 2'b10;  
        14: {p, d} = 2'b00;  
        15: {p, d} = 2'b01;  
    endcase  
endmodule
```

## VHDL

```
library IEEE; use IEEE.STD_LOGIC_1164.all;  
  
entity ex4_18 is  
    port(a: in STD_LOGIC_VECTOR(3 downto 0);  
         p, d: out STD_LOGIC);  
end;  
  
architecture synth of ex4_18 is  
    signal vars: STD_LOGIC_VECTOR(1 downto 0);  
begin  
    p <= vars(1);  
    d <= vars(0);  
    process(all) begin  
        case a is  
            when X"0" => vars <= "00";  
            when X"1" => vars <= "00";  
            when X"2" => vars <= "10";  
            when X"3" => vars <= "11";  
            when X"4" => vars <= "00";  
            when X"5" => vars <= "10";  
            when X"6" => vars <= "01";  
            when X"7" => vars <= "10";  
            when X"8" => vars <= "00";  
            when X"9" => vars <= "01";  
            when X"A" => vars <= "00";  
            when X"B" => vars <= "10";  
            when X"C" => vars <= "01";  
            when X"D" => vars <= "10";  
            when X"E" => vars <= "00";  
            when X"F" => vars <= "01";  
            when others => vars <= "00";  
        end case;  
    end process;  
end;
```

### Exercise 4.21

---

## SystemVerilog

```

module priority_encoder2(input  logic [7:0] a,
                        output logic [2:0] y, z,
                        output logic      none);

always_comb
begin
    casez (a)
        8'b00000000: begin y = 3'd0; none = 1'b1; end
        8'b00000001: begin y = 3'd0; none = 1'b0; end
        8'b0000001?: begin y = 3'd1; none = 1'b0; end
        8'b000001??: begin y = 3'd2; none = 1'b0; end
        8'b00001??: begin y = 3'd3; none = 1'b0; end
        8'b0001??: begin y = 3'd4; none = 1'b0; end
        8'b001??: begin y = 3'd5; none = 1'b0; end
        8'b01??: begin y = 3'd6; none = 1'b0; end
        8'b1??: begin y = 3'd7; none = 1'b0; end
    endcase

    casez (a)
        8'b00000011: z = 3'b000;
        8'b00000101: z = 3'b000;
        8'b00001001: z = 3'b000;
        8'b00010001: z = 3'b000;
        8'b00100001: z = 3'b000;
        8'b01000001: z = 3'b000;
        8'b10000001: z = 3'b000;
        8'b0000011?: z = 3'b001;
        8'b0000101?: z = 3'b001;
        8'b0001001?: z = 3'b001;
        8'b0010001?: z = 3'b001;
        8'b0100001?: z = 3'b001;
        8'b1000001?: z = 3'b001;
        8'b000011??: z = 3'b010;
        8'b000101??: z = 3'b010;
        8'b001001??: z = 3'b010;
        8'b010001??: z = 3'b010;
        8'b100001??: z = 3'b010;
        8'b00011??: z = 3'b011;
        8'b00101??: z = 3'b011;
        8'b01001??: z = 3'b011;
        8'b10001??: z = 3'b011;
        8'b0011??: z = 3'b100;
        8'b0101??: z = 3'b100;
        8'b1001??: z = 3'b100;
        8'b011??: z = 3'b101;
        8'b101??: z = 3'b101;
        8'b11??: z = 3'b110;
        default: z = 3'b000;
    endcase
end
endmodule

```

## VHDL

```

library IEEE; use IEEE.STD_LOGIC_1164.all;

entity priority_encoder2 is
    port(a: in STD_LOGIC_VECTOR(7 downto 0);
         y, z: out STD_LOGIC_VECTOR(2 downto 0);
         none: out STD_LOGIC);
end;

architecture synth of priority_encoder is
begin
    process(all) begin
        case? a is
            when "00000000" => y <= "000"; none <= '1';
            when "00000001" => y <= "000"; none <= '0';
            when "0000001-" => y <= "001"; none <= '0';
            when "000001--" => y <= "010"; none <= '0';
            when "00001---" => y <= "011"; none <= '0';
            when "0001----" => y <= "100"; none <= '0';
            when "001-----" => y <= "101"; none <= '0';
            when "01-----" => y <= "110"; none <= '0';
            when "1-----" => y <= "111"; none <= '0';
            when others => y <= "000"; none <= '0';
        end case?;
        case? a is
            when "00000011" => z <= "000";
            when "00000101" => z <= "000";
            when "00001001" => z <= "000";
            when "00001001" => z <= "000";
            when "00010001" => z <= "000";
            when "00100001" => z <= "000";
            when "01000001" => z <= "000";
            when "10000001" => z <= "000";
            when "0000011-" => z <= "001";
            when "0000101-" => z <= "001";
            when "0001001-" => z <= "001";
            when "0010001-" => z <= "001";
            when "0100001-" => z <= "001";
            when "1000001-" => z <= "001";
            when "000011--" => z <= "010";
            when "000101--" => z <= "010";
            when "000101--" => z <= "010";
            when "001001--" => z <= "010";
            when "010001--" => z <= "010";
            when "100001--" => z <= "010";
            when "00011---" => z <= "011";
            when "00101---" => z <= "011";
            when "01001---" => z <= "011";
            when "10001---" => z <= "011";
            when "0011----" => z <= "100";
            when "0101----" => z <= "100";
            when "1001----" => z <= "100";
            when "011-----" => z <= "101";
            when "101-----" => z <= "101";
            when "11-----" => z <= "110";
            when others => z <= "000";
        end case?;
    end process;
end;

```

**Exercise 4.23**

**SystemVerilog**

```

module month31days(input logic [3:0] month,
                  output logic y);

always_comb
    casez (month)
        1: y = 1'b1;
        2: y = 1'b0;
        3: y = 1'b1;
        4: y = 1'b0;
        5: y = 1'b1;
        6: y = 1'b0;
        7: y = 1'b1;
        8: y = 1'b1;
        9: y = 1'b0;
        10: y = 1'b1;
        11: y = 1'b0;
        12: y = 1'b1;
        default: y = 1'b0;
    endcase
endmodule
    
```

**VHDL**

```

library IEEE; use IEEE.STD_LOGIC_1164.all;

entity month31days is
    port(a: in STD_LOGIC_VECTOR(3 downto 0);
         y: out STD_LOGIC);
end;

architecture synth of month31days is
begin
    process(all) begin
        case a is
            when X"1" => y <= '1';
            when X"2" => y <= '0';
            when X"3" => y <= '1';
            when X"4" => y <= '0';
            when X"5" => y <= '1';
            when X"6" => y <= '0';
            when X"7" => y <= '1';
            when X"8" => y <= '1';
            when X"9" => y <= '0';
            when X"A" => y <= '1';
            when X"B" => y <= '0';
            when X"C" => y <= '1';
            when others => y <= '0';
        end case;
    end process;
end;
    
```

**Exercise 4.25**

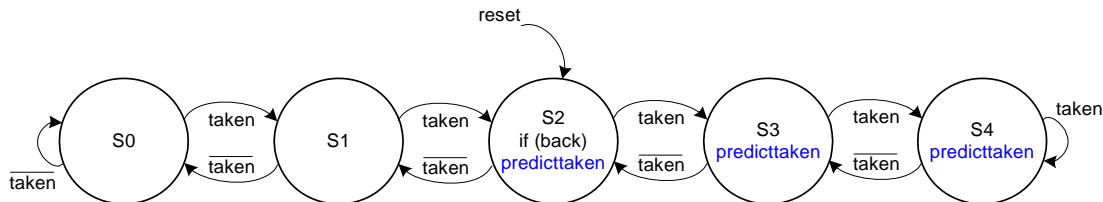

FIGURE 4.1 State transition diagram for Exercise 4.25

**Exercise 4.27**

---

**SystemVerilog**

```
module jkflop(input logic j, k, clk,
             output logic q);

    always @(posedge clk)
        case ({j,k})
            2'b01: q <= 1'b0;
            2'b10: q <= 1'b1;
            2'b11: q <= ~q;
        endcase
endmodule
```

**VHDL**

```
library IEEE; use IEEE.STD_LOGIC_1164.all;

entity jkflop is
    port(j, k, clk: in STD_LOGIC;
         q: inout STD_LOGIC);
end;

architecture synth of jkflop is
    signal jk: STD_LOGIC_VECTOR(1 downto 0);
begin
    jk <= j & k;
    process(clk) begin
        if rising_edge(clk) then
            if j = '1' and k = '0'
                then q <= '1';
            elsif j = '0' and k = '1'
                then q <= '0';
            elsif j = '1' and k = '1'
                then q <= not q;
            end if;
        end if;
    end process;
end;
```

**Exercise 4.29**

---

## SystemVerilog

```
module trafficFSM(input logic clk, reset, ta, tb,
                 output logic [1:0] la, lb);

    typedef enum logic [1:0] {S0, S1, S2, S3}
        statetype;
    statetype [1:0] state, nextstate;

    parameter green = 2'b00;
    parameter yellow = 2'b01;
    parameter red = 2'b10;

    // State Register
    always_ff @(posedge clk, posedge reset)
        if (reset) state <= S0;
        else state <= nextstate;

    // Next State Logic
    always_comb
        case (state)
            S0: if (ta) nextstate = S0;
                else nextstate = S1;
            S1: nextstate = S2;
            S2: if (tb) nextstate = S2;
                else nextstate = S3;
            S3: nextstate = S0;
        endcase

    // Output Logic
    always_comb
        case (state)
            S0: {la, lb} = {green, red};
            S1: {la, lb} = {yellow, red};
            S2: {la, lb} = {red, green};
            S3: {la, lb} = {red, yellow};
        endcase
endmodule
```

## VHDL

```
library IEEE; use IEEE.STD_LOGIC_1164.all;

entity trafficFSM is
    port(clk, reset, ta, tb: in STD_LOGIC;
         la, lb: inout STD_LOGIC_VECTOR(1 downto 0));
end;

architecture behave of trafficFSM is
    type statetype is (S0, S1, S2, S3);
    signal state, nextstate: statetype;
    signal lalb: STD_LOGIC_VECTOR(3 downto 0);
begin
    -- state register
    process(clk, reset) begin
        if reset then state <= S0;
        elsif rising_edge(clk) then
            state <= nextstate;
        end if;
    end process;

    -- next state logic
    process(all) begin
        case state is
            when S0 => if ta then
                nextstate <= S0;
            else nextstate <= S1;
            end if;
            when S1 => nextstate <= S2;
            when S2 => if tb then
                nextstate <= S2;
            else nextstate <= S3;
            end if;
            when S3 => nextstate <= S0;
            when others => nextstate <= S0;
        end case;
    end process;

    -- output logic
    la <= lalb(3 downto 2);
    lb <= lalb(1 downto 0);
    process(all) begin
        case state is
            when S0 => lalb <= "0010";
            when S1 => lalb <= "0110";
            when S2 => lalb <= "1000";
            when S3 => lalb <= "1001";
            when others => lalb <= "1010";
        end case;
    end process;
end;
```

**Exercise 4.31**

---

**SystemVerilog**

```
module fig3_42(input  logic clk, a, b, c, d,
              output logic x, y);

    logic n1, n2;
    logic areg, breg, creg, dreg;

    always_ff @(posedge clk) begin
        areg <= a;
        breg <= b;
        creg <= c;
        dreg <= d;
        x <= n2;
        y <= ~(dreg | n2);
    end

    assign n1 = areg & breg;
    assign n2 = n1 | creg;
endmodule
```

**VHDL**

```
library IEEE; use IEEE.STD_LOGIC_1164.all;

entity fig3_42 is
    port(clk, a, b, c, d: in  STD_LOGIC;
         x, y: out STD_LOGIC);
end;

architecture synth of fig3_40 is
    signal n1, n2, areg, breg, creg, dreg: STD_LOGIC;
begin
    process(clk) begin
        if rising_edge(clk) then
            areg <= a;
            breg <= b;
            creg <= c;
            dreg <= d;
            x <= n2;
            y <= not (dreg or n2);
        end if;
    end process;

    n1 <= areg and breg;
    n2 <= n1 or creg;
end;
```

**Exercise 4.33**

---

## SystemVerilog

```
module fig3_70(input logic clk, reset, a, b,
              output logic q);
    typedef enum logic [1:0] {S0, S1, S2} statetype;
    statetype [1:0] state, nextstate;

    // State Register
    always_ff @(posedge clk, posedge reset)
        if (reset) state <= S0;
        else state <= nextstate;

    // Next State Logic
    always_comb
        case (state)
            S0: if (a) nextstate = S1;
                else nextstate = S0;
            S1: if (b) nextstate = S2;
                else nextstate = S0;
            S2: if (a & b) nextstate = S2;
                else nextstate = S0;
            default: nextstate = S0;
        endcase

    // Output Logic
    always_comb
        case (state)
            S0: q = 0;
            S1: q = 0;
            S2: if (a & b) q = 1;
                else q = 0;
            default: q = 0;
        endcase
endmodule
```

## VHDL

```
library IEEE; use IEEE.STD_LOGIC_1164.all;

entity fig3_70 is
    port(clk, reset, a, b: in STD_LOGIC;
         q: out STD_LOGIC);
end;

architecture synth of fig3_70 is
    type statetype is (S0, S1, S2);
    signal state, nextstate: statetype;
begin
    -- state register
    process(clk, reset) begin
        if reset then state <= S0;
        elsif rising_edge(clk) then
            state <= nextstate;
        end if;
    end process;

    -- next state logic
    process(all) begin
        case state is
            when S0 => if a then
                nextstate <= S1;
            else nextstate <= S0;
            end if;
            when S1 => if b then
                nextstate <= S2;
            else nextstate <= S0;
            end if;
            when S2 => if (a = '1' and b = '1') then
                nextstate <= S2;
            else nextstate <= S0;
            end if;
            when others => nextstate <= S0;
        end case;
    end process;

    -- output logic
    q <= '1' when ( (state = S2) and
                   (a = '1' and b = '1'))
        else '0';
end;
```

---

### Exercise 4.35



## SystemVerilog

```

module daughterfsm(input  logic clk, reset, a,
                  output logic smile);
    typedef enum logic [1:0] {S0, S1, S2, S3, S4}
        statetype;
    statetype [2:0] state, nextstate;

    // State Register
    always_ff @(posedge clk, posedge reset)
        if (reset) state <= S0;
        else      state <= nextstate;

    // Next State Logic
    always_comb
        case (state)
            S0: if (a) nextstate = S1;
                else nextstate = S0;
            S1: if (a) nextstate = S2;
                else nextstate = S0;
            S2: if (a) nextstate = S4;
                else nextstate = S3;
            S3: if (a) nextstate = S1;
                else nextstate = S0;
            S4: if (a) nextstate = S4;
                else nextstate = S3;
            default: nextstate = S0;
        endcase

    // Output Logic
    assign smile = ((state == S3) & a) |
                  ((state == S4) & ~a);
endmodule

```

## VHDL

```

library IEEE; use IEEE.STD_LOGIC_1164.all;

entity daughterfsm is
    port(clk, reset, a: in  STD_LOGIC;
         smile:      out STD_LOGIC);
end;

architecture synth of daughterfsm is
    type statetype is (S0, S1, S2, S3, S4);
    signal state, nextstate: statetype;
begin
    -- state register
    process(clk, reset) begin
        if reset then state <= S0;
        elsif rising_edge(clk) then
            state <= nextstate;
        end if;
    end process;

    -- next state logic
    process(all) begin
        case state is
            when S0 => if a then
                            nextstate <= S1;
                        else nextstate <= S0;
                    end if;
            when S1 => if a then
                            nextstate <= S2;
                        else nextstate <= S0;
                    end if;
            when S2 => if a then
                            nextstate <= S4;
                        else nextstate <= S3;
                    end if;
            when S3 => if a then
                            nextstate <= S1;
                        else nextstate <= S0;
                    end if;
            when S4 => if a then
                            nextstate <= S4;
                        else nextstate <= S3;
                    end if;
            when others => nextstate <= S0;
        end case;
    end process;

    -- output logic
    smile <= '1' when ( ((state = S3) and (a = '1')) or
                       ((state = S4) and (a = '0')) )
              else '0';
end;

```

### Exercise 4.37

---

#### SystemVerilog

```
module ex4_37(input logic clk, reset,
             output logic [2:0] q);
    typedef enum logic [2:0] {S0 = 3'b000,
                             S1 = 3'b001,
                             S2 = 3'b011,
                             S3 = 3'b010,
                             S4 = 3'b110,
                             S5 = 3'b111,
                             S6 = 3'b101,
                             S7 = 3'b100}
        statetype;

    statetype [2:0] state, nextstate;

    // State Register
    always_ff @(posedge clk, posedge reset)
        if (reset) state <= S0;
        else state <= nextstate;

    // Next State Logic
    always_comb
        case (state)
            S0: nextstate = S1;
            S1: nextstate = S2;
            S2: nextstate = S3;
            S3: nextstate = S4;
            S4: nextstate = S5;
            S5: nextstate = S6;
            S6: nextstate = S7;
            S7: nextstate = S0;
        endcase

    // Output Logic
    assign q = state;
endmodule
```

#### VHDL

```
library IEEE; use IEEE.STD_LOGIC_1164.all;

entity ex4_37 is
    port(clk: in STD_LOGIC;
         reset: in STD_LOGIC;
         q: out STD_LOGIC_VECTOR(2 downto 0));
end;

architecture synth of ex4_37 is
    signal state: STD_LOGIC_VECTOR(2 downto 0);
    signal nextstate: STD_LOGIC_VECTOR(2 downto 0);
begin
    -- state register
    process(clk, reset) begin
        if reset then state <= "000";
        elsif rising_edge(clk) then
            state <= nextstate;
        end if;
    end process;

    -- next state logic
    process(all) begin
        case state is
            when "000" => nextstate <= "001";
            when "001" => nextstate <= "011";
            when "011" => nextstate <= "010";
            when "010" => nextstate <= "110";
            when "110" => nextstate <= "111";
            when "111" => nextstate <= "101";
            when "101" => nextstate <= "100";
            when "100" => nextstate <= "000";
            when others => nextstate <= "000";
        end case;
    end process;

    -- output logic
    q <= state;
end;
```

### Exercise 4.39

---

### Option 1

#### SystemVerilog

```

module ex4_39(input logic clk, reset, a, b,
             output logic z);
    typedef enum logic [1:0] {S0, S1, S2, S3}
        statetype;
    statetype [1:0] state, nextstate;

    // State Register
    always_ff @(posedge clk, posedge reset)
        if (reset) state <= S0;
        else state <= nextstate;

    // Next State Logic
    always_comb
        case (state)
            S0: case ({b,a})
                2'b00: nextstate = S0;
                2'b01: nextstate = S3;
                2'b10: nextstate = S0;
                2'b11: nextstate = S1;
            endcase
            S1: case ({b,a})
                2'b00: nextstate = S0;
                2'b01: nextstate = S3;
                2'b10: nextstate = S2;
                2'b11: nextstate = S1;
            endcase
            S2: case ({b,a})
                2'b00: nextstate = S0;
                2'b01: nextstate = S3;
                2'b10: nextstate = S2;
                2'b11: nextstate = S1;
            endcase
            S3: case ({b,a})
                2'b00: nextstate = S0;
                2'b01: nextstate = S3;
                2'b10: nextstate = S2;
                2'b11: nextstate = S1;
            endcase
            default: nextstate = S0;
        endcase

    // Output Logic
    always_comb
        case (state)
            S0: z = a & b;
            S1: z = a | b;
            S2: z = a & b;
            S3: z = a | b;
            default: z = 1'b0;
        endcase
    endmodule

```

#### VHDL

```

library IEEE; use IEEE.STD_LOGIC_1164.all;

entity ex4_39 is
    port(clk: in STD_LOGIC;
         reset: in STD_LOGIC;
         a, b: in STD_LOGIC;
         z: out STD_LOGIC);
end;

architecture synth of ex4_39 is
    type statetype is (S0, S1, S2, S3);
    signal state, nextstate: statetype;
    signal ba: STD_LOGIC_VECTOR(1 downto 0);
begin
    -- state register
    process(clk, reset) begin
        if reset then state <= S0;
        elsif rising_edge(clk) then
            state <= nextstate;
        end if;
    end process;

    -- next state logic
    ba <= b & a;
    process(all) begin
        case state is
            when S0 =>
                case (ba) is
                    when "00" => nextstate <= S0;
                    when "01" => nextstate <= S3;
                    when "10" => nextstate <= S0;
                    when "11" => nextstate <= S1;
                    when others => nextstate <= S0;
                end case;
            when S1 =>
                case (ba) is
                    when "00" => nextstate <= S0;
                    when "01" => nextstate <= S3;
                    when "10" => nextstate <= S2;
                    when "11" => nextstate <= S1;
                    when others => nextstate <= S0;
                end case;
            when S2 =>
                case (ba) is
                    when "00" => nextstate <= S0;
                    when "01" => nextstate <= S3;
                    when "10" => nextstate <= S2;
                    when "11" => nextstate <= S1;
                    when others => nextstate <= S0;
                end case;
            when S3 =>
                case (ba) is
                    when "00" => nextstate <= S0;
                    when "01" => nextstate <= S3;
                    when "10" => nextstate <= S2;
                    when "11" => nextstate <= S1;
                    when others => nextstate <= S0;
                end case;
            when others => nextstate <= S0;
        end case;
    end process;
end architecture;

```

*(continued from previous page)*

## VHDL

```
-- output logic
process(all) begin
  case state is
    when S0 => if (a = '1' and b = '1')
                then z <= '1';
                else z <= '0';
              end if;
    when S1 => if (a = '1' or b = '1')
                then z <= '1';
                else z <= '0';
              end if;
    when S2 => if (a = '1' and b = '1')
                then z <= '1';
                else z <= '0';
              end if;
    when S3 => if (a = '1' or b = '1')
                then z <= '1';
                else z <= '0';
              end if;
    when others => z <= '0';
  end case;
end process;
end;
```

## Option 2

### SystemVerilog

```
module ex4_37(input logic clk, a, b,
             output logic z);

  logic aprev;

  // State Register
  always_ff @(posedge clk)
    aprev <= a;

  assign z = b ? (aprev | a) : (aprev & a);
endmodule
```

### VHDL

```
library IEEE; use IEEE.STD_LOGIC_1164.all;

entity ex4_37 is
  port(clk: in STD_LOGIC;
        a, b: in STD_LOGIC;
        z: out STD_LOGIC);
end;

architecture synth of ex4_37 is
  signal aprev, nland, n2or: STD_LOGIC;
begin
  -- state register
  process(clk) begin
    if rising_edge(clk) then
      aprev <= a;
    end if;
  end process;

  z <= (a or aprev) when b = '1' else
      (a and aprev);
end;
```

**Exercise 4.41**

---

**SystemVerilog**

```

module ex4_41(input  logic clk, start, a,
              output logic q);
  typedef enum logic [1:0] {S0, S1, S2, S3}
    statetype;
  statetype [1:0] state, nextstate;

  // State Register
  always_ff @(posedge clk, posedge start)
    if (start) state <= S0;
    else      state <= nextstate;

  // Next State Logic
  always_comb
    case (state)
      S0: if (a) nextstate = S1;
          else nextstate = S0;
      S1: if (a) nextstate = S2;
          else nextstate = S3;
      S2: if (a) nextstate = S2;
          else nextstate = S3;
      S3: if (a) nextstate = S2;
          else nextstate = S3;
    endcase

  // Output Logic
  assign q = state[0];
endmodule

```

**VHDL**

```

library IEEE; use IEEE.STD_LOGIC_1164.all;

entity ex4_41 is
  port(clk, start, a: in  STD_LOGIC;
        q:      out STD_LOGIC);
end;

architecture synth of ex4_41 is
  type statetype is (S0, S1, S2, S3);
  signal state, nextstate: statetype;
begin
  -- state register
  process(clk, start) begin
    if start then state <= S0;
    elsif rising_edge(clk) then
      state <= nextstate;
    end if;
  end process;

  -- next state logic
  process(all) begin
    case state is
      when S0 => if a then
                    nextstate <= S1;
                  else nextstate <= S0;
                end if;
      when S1 => if a then
                    nextstate <= S2;
                  else nextstate <= S3;
                end if;
      when S2 => if a then
                    nextstate <= S2;
                  else nextstate <= S3;
                end if;
      when S3 => if a then
                    nextstate <= S2;
                  else nextstate <= S3;
                end if;
      when others => nextstate <= S0;
    end case;
  end process;

  -- output logic
  q <= '1' when ((state = S1) or (state = S3))
    else '0';
end;

```

**Exercise 4.43**

---

## SystemVerilog

```
module ex4_43(input clk, reset, a,
             output q);
    typedef enum logic [1:0] {S0, S1, S2} statetype;
    statetype [1:0] state, nextstate;

    // State Register
    always_ff @(posedge clk, posedge reset)
        if (reset) state <= S0;
        else state <= nextstate;

    // Next State Logic
    always_comb
        case (state)
            S0: if (a) nextstate = S1;
                else nextstate = S0;
            S1: if (a) nextstate = S2;
                else nextstate = S0;
            S2: if (a) nextstate = S2;
                else nextstate = S0;
            default: nextstate = S0;
        endcase

    // Output Logic
    assign q = state[1];
endmodule
```

## VHDL

```
library IEEE; use IEEE.STD_LOGIC_1164.all;

entity ex4_43 is
    port(clk, reset, a: in STD_LOGIC;
         q: out STD_LOGIC);
end;

architecture synth of ex4_43 is
    type statetype is (S0, S1, S2);
    signal state, nextstate: statetype;
begin
    -- state register
    process(clk, reset) begin
        if reset then state <= S0;
        elsif rising_edge(clk) then
            state <= nextstate;
        end if;
    end process;

    -- next state logic
    process(all) begin
        case state is
            when S0 => if a then
                            nextstate <= S1;
                        else nextstate <= S0;
                        end if;
            when S1 => if a then
                            nextstate <= S2;
                        else nextstate <= S0;
                        end if;
            when S2 => if a then
                            nextstate <= S2;
                        else nextstate <= S0;
                        end if;
            when others => nextstate <= S0;
        end case;
    end process;

    -- output logic
    q <= '1' when (state = S2) else '0';
end;
```

---

## Exercise 4.45

## SystemVerilog

```

module ex4_45(input logic clk, c,
             input logic [1:0] a, b,
             output logic [1:0] s);

    logic [1:0] areg, breg;
    logic creg;
    logic [1:0] sum;
    logic cout;

    always_ff @(posedge clk)
        {areg, breg, creg, s} <= {a, b, c, sum};

    fulladder fulladd1(areg[0], breg[0], creg,
                     sum[0], cout);
    fulladder fulladd2(areg[1], breg[1], cout,
                     sum[1], );
endmodule

```

## VHDL

```

library IEEE; use IEEE.STD_LOGIC_1164.all;

entity ex4_45 is
    port(clk, c: in STD_LOGIC;
         a, b: in STD_LOGIC_VECTOR(1 downto 0);
         s: out STD_LOGIC_VECTOR(1 downto 0));
end;

architecture synth of ex4_45 is
    component fulladder is
        port(a, b, cin: in STD_LOGIC;
             s, cout: out STD_LOGIC);
    end component;
    signal creg: STD_LOGIC;
    signal areg, breg, cout: STD_LOGIC_VECTOR(1 downto 0);
    signal sum: STD_LOGIC_VECTOR(1 downto 0);
begin
    process(clk) begin
        if rising_edge(clk) then
            areg <= a;
            breg <= b;
            creg <= c;
            s <= sum;
        end if;
    end process;

    fulladd1: fulladder
        port map(areg(0), breg(0), creg, sum(0), cout(0));
    fulladd2: fulladder
        port map(areg(1), breg(1), cout(0), sum(1),
               cout(1));
end;

```

## Exercise 4.47

---

### SystemVerilog

```

module syncbad(input logic clk,
               input logic d,
               output logic q);

    logic n1;

    always_ff @(posedge clk)
        begin
            q <= n1; // nonblocking
            n1 <= d; // nonblocking
        end
endmodule
    
```

### VHDL

```

library IEEE; use IEEE.STD_LOGIC_1164.all;

entity syncbad is
    port(clk: in STD_LOGIC;
          d: in STD_LOGIC;
          q: out STD_LOGIC);
end;

architecture bad of syncbad is
begin
    process(clk)
        variable n1: STD_LOGIC;
    begin
        if rising_edge(clk) then
            q <= n1; -- nonblocking
            n1 <= d; -- nonblocking
        end if;
    end process;
end;
    
```

### Exercise 4.49

---

They do not have the same function.

code1

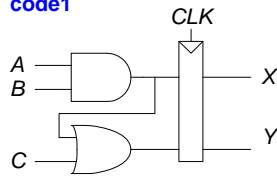

code2

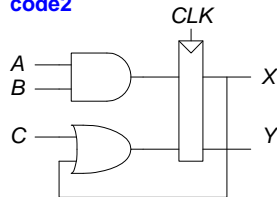

### Exercise 4.51

---

It is necessary to write



```
q <= '1' when state = S0 else '0';
```

rather than simply

```
q <= (state = S0);
```

because the result of the comparison (`state = S0`) is of type `Boolean` (true and false) and `q` must be assigned a value of type `STD_LOGIC` ('1' and '0').

### Question 4.1

---

#### SystemVerilog

```
assign result = sel ? data : 32'b0;
```

#### VHDL

```
result <= data when sel = '1' else X"00000000";
```

### Question 4.3

---

The SystemVerilog statement performs the bit-wise AND of the 16 least significant bits of data with 0xC820. It then ORs these 16 bits to produce the 1-bit result.

# CHAPTER 5

## Exercise 5.1

---

(a) From Equation 5.1, we find the 64-bit ripple-carry adder delay to be:

$$t_{\text{ripple}} = Nt_{\text{FA}} = 64(450 \text{ ps}) = 28.8 \text{ ns}$$

(b) From Equation 5.6, we find the 64-bit carry-lookahead adder delay to be:

$$t_{\text{CLA}} = t_{\text{pg}} + t_{\text{pg\_block}} + \left(\frac{N}{k} - 1\right)t_{\text{AND\_OR}} + kt_{\text{FA}}$$

$$t_{\text{CLA}} = \left[150 + (6 \times 150) + \left(\frac{64}{4} - 1\right)300 + (4 \times 450)\right] = 7.35 \text{ ns}$$

(Note: the actual delay is only 7.2 ns because the first AND\_OR gate only has a 150 ps delay.)

(c) From Equation 5.11, we find the 64-bit prefix adder delay to be:

$$t_{\text{PA}} = t_{\text{pg}} + \log_2 N(t_{\text{pg\_prefix}}) + t_{\text{XOR}}$$

$$t_{\text{PA}} = [150 + 6(300) + 150] = 2.1 \text{ ns}$$

## Exercise 5.3

---

A designer might choose to use a ripple-carry adder instead of a carry-lookahead adder if chip area is the critical resource and delay is not the critical constraint.

**Exercise 5.5**

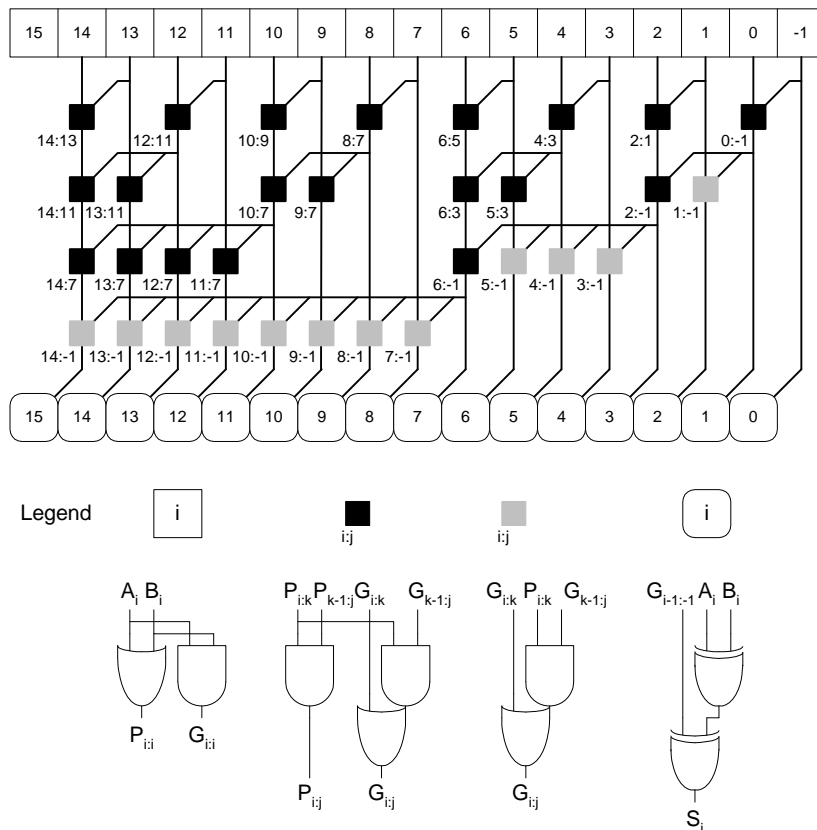

FIGURE 5.1 16-bit prefix adder with “gray cells”

**Exercise 5.7**

(a) We show an 8-bit priority circuit in Figure 5.2. In the figure  $X_7 = \bar{A}_7$ ,  $X_{7:6} = \bar{A}_7\bar{A}_6$ ,  $X_{7:5} = \bar{A}_7\bar{A}_6\bar{A}_5$ , and so on. The priority encoder’s delay is  $\log_2 N$  2-input AND gates followed by a final row of 2-input AND gates. The final stage is an  $(N/2)$ -input OR gate. Thus, in general, the delay of an  $N$ -input priority encoder is:

$$t_{pd\_priority} = (\log_2 N + 1)t_{pd\_AND2} + t_{pd\_ORN/2}$$

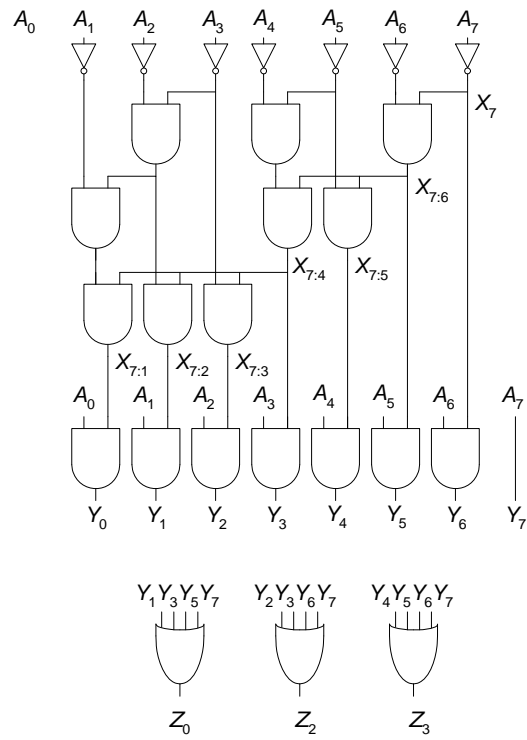

FIGURE 5.2 8-input priority encoder

## SystemVerilog

```
module priorityckt(input logic [7:0] a,
                  output logic [2:0] z);
    logic [7:0] y;
    logic x7, x76, x75, x74, x73, x72, x71;
    logic x32, x54, x31;
    logic [7:0] abar;

    // row of inverters
    assign abar = ~a;

    // first row of AND gates
    assign x7 = abar[7];
    assign x76 = abar[6] & x7;
    assign x54 = abar[4] & abar[5];
    assign x32 = abar[2] & abar[3];

    // second row of AND gates
    assign x75 = abar[5] & x76;
    assign x74 = x54 & x76;
    assign x31 = abar[1] & x32;

    // third row of AND gates
    assign x73 = abar[3] & x74;
    assign x72 = x32 & x74;
    assign x71 = x31 & x74;

    // fourth row of AND gates
    assign y = {a[7], a[6] & x7, a[5] & x76,
               a[4] & x75, a[3] & x74, a[2] & x73,
               a[1] & x72, a[0] & x71};

    // row of OR gates
    assign z = { |{y[7:4]},
               |{y[7:6], y[3:2]},
               |{y[1], y[3], y[5], y[7]} };
endmodule
```

## VHDL

```
library IEEE; use IEEE.STD_LOGIC_1164.all;

entity priorityckt is
    port(a: in STD_LOGIC_VECTOR(7 downto 0);
         z: out STD_LOGIC_VECTOR(2 downto 0));
end;

architecture synth of priorityckt is
    signal y, abar: STD_LOGIC_VECTOR(7 downto 0);
    signal x7, x76, x75, x74, x73, x72, x71,
           x32, x54, x31: STD_LOGIC;
begin
    -- row of inverters
    abar <= not a;

    -- first row of AND gates
    x7 <= abar(7);
    x76 <= abar(6) and x7;
    x54 <= abar(4) and abar(5);
    x32 <= abar(2) and abar(3);

    -- second row of AND gates
    x75 <= abar(5) and x76;
    x74 <= x54 and x76;
    x31 <= abar(1) and x32;

    -- third row of AND gates
    x73 <= abar(3) and x74;
    x72 <= x32 and x74;
    x71 <= x31 and x74;

    -- fourth row of AND gates
    y <= (a(7) & (a(6) and x7) & (a(5) and x76) &
          (a(4) and x75) & (a(3) and x74) & (a(2) and
x73) &
          (a(1) and x72) & (a(0) and x71));

    -- row of OR gates
    z <= ( (y(7) or y(6) or y(5) or y(4)) &
          (y(7) or y(6) or y(3) or y(2)) &
          (y(1) or y(3) or y(5) or y(7)) );
end;
```

## Exercise 5.9

---

(a) Answers will vary.

**3 and 5:**  $3 - 5 = 0011_2 - 0101_2 = 0011_2 + 1010_2 + 1 = 1110_2 (= -2_{10})$ . The sign bit (most significant bit) is 1, so the 4-bit signed comparator of Figure 5.12 correctly computes that 3 is less than 5.

(b) Answers will vary.

**-3 and 6:**  $-3 - 6 = 1101 - 0110 = 1101 + 1001 + 1 = 01112 (= -7, \text{ but overflow occurred } - \text{ the result should be } -9)$ . The sign bit (most significant bit) is 0, so the 4-bit signed comparator of Figure 5.12 **incorrectly** computes that -3 is **not** less than 6.

(c) In the general, the  $N$ -bit signed comparator of Figure 5.12 operates incorrectly upon overflow.

### Exercise 5.11

#### SystemVerilog

```
module alu(input  logic [31:0] a, b,
          input  logic [1:0] ALUControl,
          output logic [31:0] Result);

    logic [31:0] condinvb;
    logic [32:0] sum;

    assign condinvb = ALUControl[0] ? ~b : b;
    assign sum = a + condinvb + ALUControl[0];

    always_comb
        casex (ALUControl[1:0])
            2'b0?: Result = sum;
            2'b10: Result = a & b;
            2'b11: Result = a | b;
        endcase

endmodule
```

#### VHDL

```
library IEEE; use IEEE.STD_LOGIC_1164.all;
use IEEE.NUMERIC_STD_UNSIGNED.all;
entity alu is
    port(a, b:          in  STD_LOGIC_VECTOR(31 downto 0);
         ALUControl: in  STD_LOGIC_VECTOR(1 downto 0);
         Result:       buffer STD_LOGIC_VECTOR(31 downto 0));
end;

architecture behave of alu is
    signal condinvb: STD_LOGIC_VECTOR(31 downto 0);
    signal sum:      STD_LOGIC_VECTOR(32 downto 0);
begin
    condinvb <= not b when ALUControl(0) else b;
    sum <= ('0', a) + ('0', condinvb) + ALUControl(0);

    process(all) begin
        case? ALUControl(1 downto 0) is
            when "0-" => result <= sum(31 downto 0);
            when "10" => result <= a and b;
            when "11" => result <= a or b;
            when others => result <= (others => '-');
        end case?;
    end process;
end;
```

```

    end process;
end;
```

### Exercise 5.13

#### SystemVerilog

```

module testbench();
    logic clk;
    logic [31:0] a, b, y, y_expected;
    logic [1:0] ALUControl;

    logic [31:0] vectornum, errors;
    logic [99:0] testvectors[10000:0];

    // instantiate device under test
    alu dut(a, b, ALUControl, y);

    // generate clock
    always begin
        clk = 1; #50; clk = 0; #50;
    end

    // at start of test, load vectors
    initial begin
        $readmemh("ex5.13_alu.tv", testvectors);
        vectornum = 0; errors = 0;
    end

    // apply test vectors at rising edge of clock
    always @(posedge clk)
        begin
            #1;
            ALUControl = testvectors[vectornum][97:96];
            a = testvectors[vectornum][95:64];
            b = testvectors[vectornum][63:32];
            y_expected = testvectors[vectornum][31:0];
        end

    // check results on falling edge of clock
    always @(negedge clk)
        begin
            if (y != y_expected) begin
                $display("Error in vector %d", vectornum);
                $display(" Inputs : a = %h, b = %h, ALUControl = %b", a, b, ALUControl);
                $display(" Outputs: y = %h (%h expected)",
                    y, y_expected);
                errors = errors+1;
            end
            vectornum = vectornum + 1;
            if (testvectors[vectornum][0] === 1'bx) begin
                $display("%d tests completed with %d errors", vectornum, errors);
                $stop;
            end
        end
endmodule
```

#### VHDL

```

library IEEE;
use IEEE.STD_LOGIC_1164.all; use STD.TEXTIO.all;
use IEEE.STD_LOGIC_UNSIGNED.all;
use IEEE.STD_LOGIC_ARITH.all;
```

```

entity testbench is -- no inputs or outputs
end;

architecture sim of testbench is
  component alu
    port(a, b:          in      STD_LOGIC_VECTOR(31 downto 0);
         ALUControl: in      STD_LOGIC_VECTOR(1 downto 0);
         Result:       buffer STD_LOGIC_VECTOR(31 downto 0));
  end component;
  signal a, b, Result, Result_expected: STD_LOGIC_VECTOR(31 downto 0);
  signal ALUControl: STD_LOGIC_VECTOR(1 downto 0);
  signal clk, reset: STD_LOGIC;
  constant MEMSIZE: integer := 99;
  type tarray is array(MEMSIZE downto 0) of STD_LOGIC_VECTOR(99 downto 0);
  shared variable testvectors: tarray;
  shared variable vectornum, errors: integer;
begin
  -- instantiate device under test
  dut: alu port map(a, b, ALUControl, Result);

  -- generate clock
  process begin
    clk <= '1'; wait for 5 ns;
    clk <= '0'; wait for 5 ns;
  end process;

  -- at start of test, pulse reset
  process begin
    reset <= '1'; wait for 27 ns; reset <= '0';
    wait;
  end process;

  -- run tests
  -- at start of test, load vectors
  process is
    file tv: TEXT;
    variable i, index, count: integer;
    variable L: line;
    variable ch: character;
    variable readvalue: integer;
  begin
    -- read file of test vectors
    i := 0;
    index := 0;
    FILE_OPEN(tv, "ex5.13_alu.tv", READ_MODE);
    report "Opening file\n";
    while (not endfile(tv)) loop
      readline(tv, L);
      readvalue := 0;
      count := 3;
      for i in 1 to 28 loop
        read(L, ch);
        report "Line: " & integer'image(index) & " i = " &
          integer'image(i) & " char = " &
          character'image(ch)
          severity error;

        if '0' <= ch and ch <= '9' then
          readvalue := readvalue*16 + character'pos(ch)
            - character'pos('0');
        elsif 'a' <= ch and ch <= 'f' then
          readvalue := readvalue*16 + character'pos(ch)
            - character'pos('a')+10;
        end if;
      end loop;
    end while;
  end process;
end;

```



```

else report "Format error on line " &
  integer'image(index) & " i = " &
  integer'image(i) & " char = " &
  character'image(ch)
  severity error;
end if;

-- load vectors
-- assign first 4 bits (will be used for ALUControl)
if (i = 1) then
  testvectors(index)( 99 downto 96) := CONV_STD_LOGIC_VECTOR(readvalue, 4);
  count := count - 1;
  readvalue := 0; -- reset readvalue

  -- assign a, b, and Result (in testvectors) in
  -- 32-bit increments
  elsif ((i = 10) or (i = 19) or (i = 28)) then
    testvectors(index)( (count*32 + 31) downto (count*32)) :=
CONV_STD_LOGIC_VECTOR(readvalue, 32);
    count := count - 1;
    readvalue := 0; -- reset readvalue
  end if;
end loop;
index := index + 1;
end loop;

vectornum := 0; errors := 0;
reset <= '1'; wait for 27 ns; reset <= '0';
wait;
end process;

-- apply test vectors on rising edge of clk
process (clk) begin
  if (clk'event and clk = '1') then
    ALUControl <= testvectors(vectornum)(97 downto 96)
      after 1 ns;
    a <= testvectors(vectornum)(95 downto 64)
      after 1 ns;
    b <= testvectors(vectornum)(63 downto 32)
      after 1 ns;
    Result_expected <= testvectors(vectornum)(31 downto 0)
      after 1 ns;
  end if;
end process;

-- check results on falling edge of clk
process (clk) begin
  if (clk'event and clk = '0' and reset = '0') then
    if (is_x(testvectors(vectornum))) then
      if (errors = 0) then
        report "Just kidding -- " & integer'image(vectornum) & " tests completed
successfully. NO ERRORS." severity failure;
      else
        report integer'image(vectornum) & " tests completed, errors = " &
integer'image(errors) severity failure;
      end if;
    end if;
  end if;

  assert Result = Result_expected
  report "Error: vectornum = " &
integer'image(vectornum) &
", a = " & integer'image(CONV_INTEGER(a)) &

```

```

    ", b = " & integer'image(CONV_INTEGER(b)) &
    ", Result = " & integer'image(CONV_INTEGER(Result)) &
    ", ALUControl = " & integer'image(CONV_INTEGER(ALUControl));
    if (Result /= Result_expected) then
        errors := errors + 1;
    end if;
    vectornum := vectornum + 1;
end if;
end process;
end;
```

**Testvector file (ex5.13\_alu.tv)**

```

0_00000000_00000000_00000000
0_00000000_ffffffff_ffffffff
0_00000001_ffffffff_00000000
0_000000ff_00000001_00000100
1_00000000_00000000_00000000
1_00000000_ffffffff_00000001
1_00000001_00000001_00000000
1_00000100_00000001_000000ff
2_ffffffff_ffffffff_ffffffff
2_ffffffff_12345678_12345678
2_12345678_87654321_02244220
2_00000000_ffffffff_00000000
3_ffffffff_ffffffff_ffffffff
3_12345678_87654321_97755779
3_00000000_ffffffff_ffffffff
3_00000000_00000000_00000000
```

**Exercise 5.15**

$$\begin{aligned}
 (a) \quad & HS = C \\
 & LS = Z + \bar{C} \\
 & HI = \bar{Z}C = \overline{LS} \\
 & LO = \bar{C} = \overline{HS}
 \end{aligned}$$

(b)

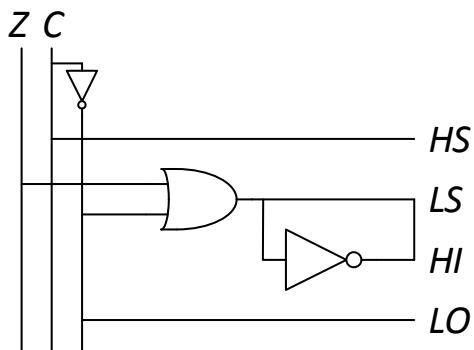

**Exercise 5.17**

A 2-bit left shifter creates the output by appending two zeros to the least significant bits of the input and dropping the two most significant bits.

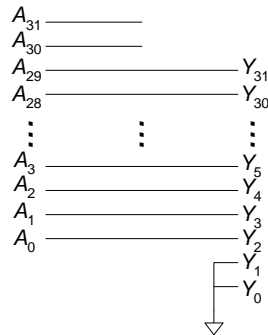

FIGURE 5.3 2-bit left shifter, 32-bit input and output

### 2-bit Left Shifter

#### SystemVerilog

```
module leftshift2_32(input  logic [31:0] a,
                   output logic [31:0] y);
    assign y = {a[29:0], 2'b0};
endmodule
```

#### VHDL

```
library IEEE;
use IEEE.STD_LOGIC_1164.all;

entity leftshift2_32 is
    port(a: in  STD_LOGIC_VECTOR(31 downto 0);
         y: out STD_LOGIC_VECTOR(31 downto 0));
end;

architecture synth of leftshift2_32 is
begin
    y <= a(29 downto 0) & "00";
end;
```

### Exercise 5.19

---

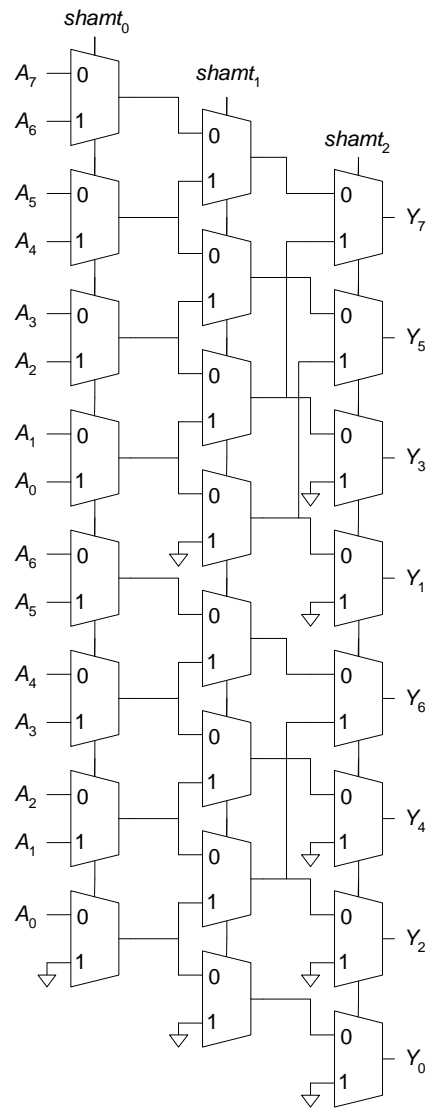

FIGURE 5.4 8-bit left shifter using 24 2:1 multiplexers

**Exercise 5.21**

(a)  $B = 0, C = A, k = shamt$

(b)  $B = A_{N-1}$  (the most significant bit of  $A$ ), repeated  $N$  times to fill all  $N$  bits of  $B$

(c)  $B = A, C = 0, k = N - shamt$

(d)  $B = A, C = A, k = shamt$

(e)  $B = A, C = A, k = N - shamt$

**Exercise 5.23**

$$t_{pd\_DIV4} = 4(4t_{FA} + t_{MUX}) = 16t_{FA} + 4t_{MUX}$$

$$t_{pd\_DIVN} = N^2t_{FA} + Nt_{MUX}$$

**Exercise 5.25**

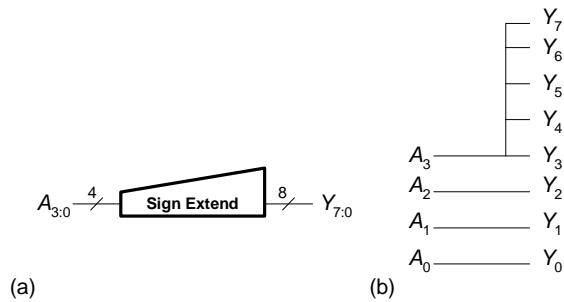

FIGURE 5.5 Sign extension unit (a) symbol, (b) underlying hardware

**SystemVerilog**

```

module signext4_8(input logic [3:0] a,
                 output logic [7:0] y);
    assign y = { {4{a[3]}}, a };
endmodule
    
```

**VHDL**

```

library IEEE;
use IEEE.STD_LOGIC_1164.all;

entity signext4_8 is
    port(a: in STD_LOGIC_VECTOR(3 downto 0);
         y: out STD_LOGIC_VECTOR(7 downto 0));
end;

architecture synth of signext4_8 is
begin
    
```

**Exercise 5.27**

---

$$\begin{array}{r}
 100.110 \\
 1100 \overline{) 111001.000} \\
 \underline{-1100} \phantom{000} \\
 001001 \phantom{0} \\
 \underline{-1100} \phantom{0} \\
 1100 \\
 \underline{-1100} \\
 0
 \end{array}$$

**Exercise 5.29**

---

- (a) 1000 1101 . 1001 0000 = 0x8D90  
 (b) 0010 1010 . 0101 0000 = 0x2A50  
 (c) 1001 0001 . 0010 1000 = 0x9128

**Exercise 5.31**

---

- (a) 1111 0010 . 0111 0000 = 0xF270  
 (b) 0010 1010 . 0101 0000 = 0x2A50  
 (c) 1110 1110 . 1101 1000 = 0xEEED8

**Exercise 5.33**

---

- (a)  $-1101.1001 = -1.1011001 \times 2^3$   
 Thus, the biased exponent =  $127 + 3 = 130 = 1000\ 0010_2$   
 In IEEE 754 single-precision floating-point format:  
 1 1000 0010 101 1001 0000 0000 0000 0000 = **0xC1590000**
- (b)  $101010.0101 = 1.010100101 \times 2^5$   
 Thus, the biased exponent =  $127 + 5 = 132 = 1000\ 0100_2$   
 In IEEE 754 single-precision floating-point format:  
 0 1000 0100 010 1001 0100 0000 0000 0000 = **0x42294000**
- (c)  $-10001.00101 = -1.000100101 \times 2^4$   
 Thus, the biased exponent =  $127 + 4 = 131 = 1000\ 0011_2$   
 In IEEE 754 single-precision floating-point format:  
 1 1000 0011 000 1001 0100 0000 0000 0000 = **0xC1894000**

**Exercise 5.35**

---

- (a) 5.5  
 (b)  $-0000.0001_2 = -0.0625$   
 (c) -8

**Exercise 5.37**

---

When adding two floating point numbers, the number with the smaller exponent is shifted to preserve the most significant bits. For example, suppose we were adding the two floating point numbers  $1.0 \times 2^0$  and  $1.0 \times 2^{-27}$ . We make the two exponents equal by shifting the second number right by 27 bits. Because the mantissa is limited to 24 bits, the second number ( $1.000\ 0000\ 0000\ 0000\ 0000 \times 2^{-27}$ ) becomes  $0.000\ 0000\ 0000\ 0000\ 0000 \times 2^0$ , because the 1 is shifted off to the right. If we had shifted the number with the larger exponent ( $1.0 \times 2^0$ ) to the left, we would have shifted off the more significant bits (on the order of  $2^0$  instead of on the order of  $2^{-27}$ ).

**Exercise 5.39**

---

- (a)  
 $0xC0D20004 = 1\ 1000\ 0001\ 101\ 0010\ 0000\ 0000\ 0000\ 0100$   
 $= -1.101\ 0010\ 0000\ 0000\ 0000\ 01 \times 2^2$   
 $0x72407020 = 0\ 1110\ 0100\ 100\ 0000\ 0111\ 0000\ 0010\ 0000$   
 $= 1.100\ 0000\ 0111\ 0000\ 001 \times 2^{101}$

When adding these two numbers together,  $0xC0D20004$  becomes:  
 $0 \times 2^{101}$  because all of the significant bits shift off the right when making the exponents equal. Thus, the result of the addition is simply the second number:

$0x72407020$

- (b)  
 $0xC0D20004 = 1\ 1000\ 0001\ 101\ 0010\ 0000\ 0000\ 0000\ 0100$   
 $= -1.101\ 0010\ 0000\ 0000\ 0000\ 01 \times 2^2$   
 $0x40DC0004 = 0\ 1000\ 0001\ 101\ 1100\ 0000\ 0000\ 0000\ 0100$   
 $= 1.101\ 1100\ 0000\ 0000\ 0000\ 01 \times 2^2$

$1.101\ 1100\ 0000\ 0000\ 0000\ 01 \times 2^2$

$$\begin{aligned}
 & - 1.101\ 0010\ 0000\ 0000\ 0000\ 01 \times 2^2 \\
 = & 0.000\ 1010 \qquad \qquad \qquad \times 2^2 \\
 = & 1.010 \times 2^{-2}
 \end{aligned}$$

$$\begin{aligned}
 & = 0\ 0111\ 1101\ 010\ 0000\ 0000\ 0000\ 0000\ 0000 \\
 & = 0x3EA00000
 \end{aligned}$$

(c)

$$\begin{aligned}
 0x5FBE4000 & = 0\ 1011\ 1111\ 011\ 1110\ 0100\ 0000\ 0000\ 0000\ 0000 \\
 & = 1.011\ 1110\ 01 \times 2^{64}
 \end{aligned}$$

$$\begin{aligned}
 0x3FF80000 & = 0\ 0111\ 1111\ 111\ 1000\ 0000\ 0000\ 0000\ 0000 \\
 & = 1.111\ 1 \times 2^0
 \end{aligned}$$

$$\begin{aligned}
 0xDFDE4000 & = 1\ 1011\ 1111\ 101\ 1110\ 0100\ 0000\ 0000\ 0000\ 0000 \\
 & = - 1.101\ 1110\ 01 \times 2^{64}
 \end{aligned}$$

$$\text{Thus, } (1.011\ 1110\ 01 \times 2^{64} + 1.111\ 1 \times 2^0) = 1.011\ 1110\ 01 \times 2^{64}$$

$$\begin{aligned}
 \text{And, } (1.011\ 1110\ 01 \times 2^{64} + 1.111\ 1 \times 2^0) - 1.101\ 1110\ 01 \times 2^{64} & = \\
 - 0.01 \times 2^{64} & = -1.0 \times 2^{64} \\
 & = 1\ 1011\ 1101\ 000\ 0000\ 0000\ 0000\ 0000\ 0000 \\
 & = \mathbf{0xDE800000}
 \end{aligned}$$

This is counterintuitive because the second number (0x3FF80000) does not affect the result because its order of magnitude is less than  $2^{23}$  of the other numbers. This second number's significant bits are shifted off when the exponents are made equal.

**Exercise 5.41**

---

(a)  $2(2^{31} - 1 - 2^{23}) = 2^{32} - 2 - 2^{24} = 4,278,190,078$

(b)  $2(2^{31} - 1) = 2^{32} - 2 = 4,294,967,294$

(c)  $\pm\infty$  and NaN are given special representations because they are often used in calculations and in representing results. These values also give useful information to the user as return values, instead of returning garbage upon overflow, underflow, or divide by zero.

**Exercise 5.43**

---



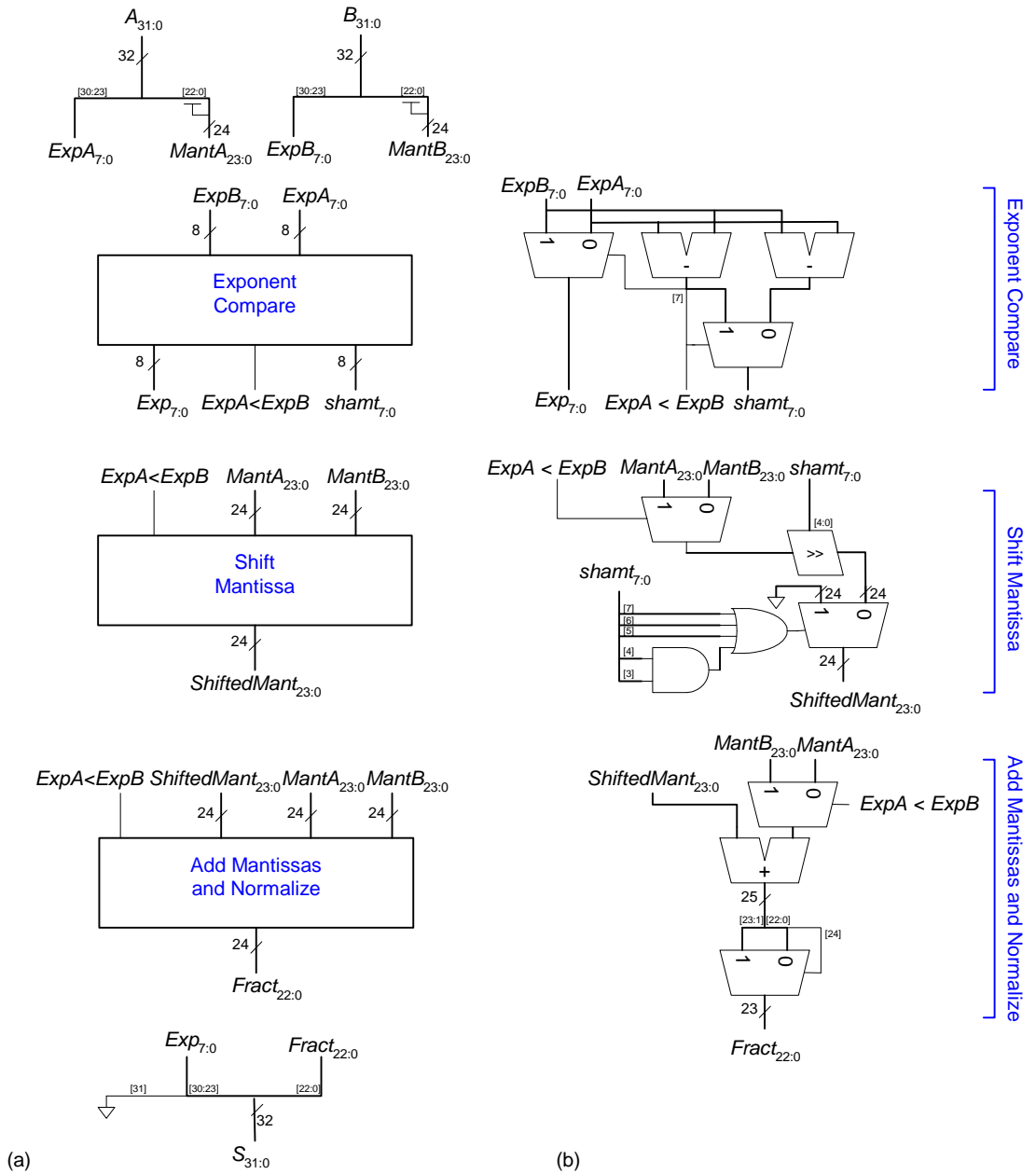

FIGURE 5.6 Floating-point adder hardware: (a) block diagram, (b) underlying hardware

## SystemVerilog

```

module fpadd(input logic [31:0] a, b,
            output logic [31:0] s);

    logic [7:0] expa, expb, exp_pre, exp, shamt;
    logic alessb;
    logic [23:0] manta, mantb, shmant;
    logic [22:0] fract;

    assign {expa, manta} = {a[30:23], 1'b1, a[22:0]};
    assign {expb, mantb} = {b[30:23], 1'b1, b[22:0]};
    assign s = {1'b0, exp, fract};

    expcomp expcomp1(expa, expb, alessb, exp_pre,
                    shamt);
    shiftmant shiftmant1(alessb, manta, mantb,
                        shamt, shmant);
    addmant addmant1(alessb, manta, mantb,
                    shmant, exp_pre, fract, exp);

endmodule
    
```

## VHDL

```

library IEEE; use IEEE.STD_LOGIC_1164.all;
use IEEE.STD_LOGIC_UNSIGNED.all;
use IEEE.STD_LOGIC_ARITH.all;

entity fpadd is
    port(a, b: in STD_LOGIC_VECTOR(31 downto 0);
         s: out STD_LOGIC_VECTOR(31 downto 0));
end;

architecture synth of fpadd is
    component expcomp
        port(expa, expb: in STD_LOGIC_VECTOR(7 downto 0);
             alessb: inout STD_LOGIC;
             exp,shamt: out STD_LOGIC_VECTOR(7 downto 0));
    end component;

    component shiftmant
        port(alessb: in STD_LOGIC;
             manta: in STD_LOGIC_VECTOR(23 downto 0);
             mantb: in STD_LOGIC_VECTOR(23 downto 0);
             shamt: in STD_LOGIC_VECTOR(7 downto 0);
             shmant: out STD_LOGIC_VECTOR(23 downto 0));
    end component;

    component addmant
        port(alessb: in STD_LOGIC;
             manta: in STD_LOGIC_VECTOR(23 downto 0);
             mantb: in STD_LOGIC_VECTOR(23 downto 0);
             shmant: in STD_LOGIC_VECTOR(23 downto 0);
             exp_pre: in STD_LOGIC_VECTOR(7 downto 0);
             fract: out STD_LOGIC_VECTOR(22 downto 0);
             exp: out STD_LOGIC_VECTOR(7 downto 0));
    end component;

    signal expa, expb: STD_LOGIC_VECTOR(7 downto 0);
    signal exp_pre, exp: STD_LOGIC_VECTOR(7 downto 0);
    signal shamt: STD_LOGIC_VECTOR(7 downto 0);
    signal alessb: STD_LOGIC;
    signal manta: STD_LOGIC_VECTOR(23 downto 0);
    signal mantb: STD_LOGIC_VECTOR(23 downto 0);
    signal shmant: STD_LOGIC_VECTOR(23 downto 0);
    signal fract: STD_LOGIC_VECTOR(22 downto 0);

begin

    expa <= a(30 downto 23);
    manta <= '1' & a(22 downto 0);
    expb <= b(30 downto 23);
    mantb <= '1' & b(22 downto 0);

    s <= '0' & exp & fract;

    expcomp1: expcomp
        port map(expa, expb, alessb, exp_pre, shamt);
    shiftmant1: shiftmant
        port map(alessb, manta, mantb, shamt, shmant);
    addmant1: addmant
        port map(alessb, manta, mantb, shmant,
                exp_pre, fract, exp);

end;
    
```

*(continued from previous page)*

### SystemVerilog

```

module expcomp(input  logic [7:0] expa, expb,
               output logic   alessb,
               output logic [7:0] exp, shamt);
    logic [7:0] aminusb, bminusa;

    assign aminusb = expa - expb;
    assign bminusa = expb - expa;
    assign alessb  = aminusb[7];

    always_comb
    if (alessb) begin
        exp = expb;
        shamt = bminusa;
    end
    else begin
        exp = expa;
        shamt = aminusb;
    end
endmodule

```

### VHDL

```

library IEEE; use IEEE.STD_LOGIC_1164.all;
use IEEE.STD_LOGIC_UNSIGNED.all;
use IEEE.STD_LOGIC_ARITH.all;

entity expcomp is
    port(expa, expb: in  STD_LOGIC_VECTOR(7 downto 0);
         alessb:   inout STD_LOGIC;
         exp,shamt: out STD_LOGIC_VECTOR(7 downto 0));
end;

architecture synth of expcomp is
    signal aminusb: STD_LOGIC_VECTOR(7 downto 0);
    signal bminusa: STD_LOGIC_VECTOR(7 downto 0);
begin
    aminusb <= expa - expb;
    bminusa <= expb - expa;
    alessb <= aminusb(7);

    exp <= expb when alessb = '1' else expa;
    shamt <= bminusa when alessb = '1' else aminusb;

end;

```

*(continued on next page)*

*(continued from previous page)*

### SystemVerilog

```
module shiftmant(input logic alessb,
                input logic [23:0] manta, mantb,
                input logic [7:0] shamt,
                output logic [23:0] shmant);
```

```
    logic [23:0] shiftedval;

    assign shiftedval = alessb ?
        (manta >> shamt) : (mantb >> shamt);
```

```
    always_comb
        if (shamt[7] | shamt[6] | shamt[5] |
            shamt[4] & shamt[3]))
            shmant = 24'b0;
        else
            shmant = shiftedval;
```

```
endmodule
```

```
module addmant(input logic alessb,
               input logic [23:0] manta,
               mantb, shmant,
               input logic [7:0] exp_pre,
               output logic [22:0] fract,
               output logic [7:0] exp);
```

```
    logic [24:0] addressult;
    logic [23:0] addval;
```

```
    assign addval = alessb ? mantb : manta;
    assign addressult = shmant + addval;
    assign fract = addressult[24] ?
        addressult[23:1] :
        addressult[22:0];
```

```
    assign exp = addressult[24] ?
        (exp_pre + 1) :
        exp_pre;
```

```
endmodule
```

### VHDL

```
library IEEE; use IEEE.STD_LOGIC_1164.all;
use ieee.numeric_std.all;
use IEEE.std_logic_unsigned.all;
```

```
entity shiftmant is
    port(alessb: in STD_LOGIC;
          manta: in STD_LOGIC_VECTOR(23 downto 0);
          mantb: in STD_LOGIC_VECTOR(23 downto 0);
          shamt: in STD_LOGIC_VECTOR(7 downto 0);
          shmant: out STD_LOGIC_VECTOR(23 downto 0));
end;
```

```
architecture synth of shiftmant is
    signal shiftedval: unsigned (23 downto 0);
    signal shiftamt_vector: STD_LOGIC_VECTOR (7 downto 0);
begin
```

```
    shiftedval <= SHIFT_RIGHT( unsigned(manta), to_in-
    teger(unsigned(shamt))) when alessb = '1'
        else SHIFT_RIGHT( unsigned(mantb), to_in-
    teger(unsigned(shamt)));
```

```
    shmant <= X"000000" when (shamt > 22)
        else STD_LOGIC_VECTOR(shiftedval);
end;
```

```
library IEEE; use IEEE.STD_LOGIC_1164.all;
use IEEE.STD_LOGIC_UNSIGNED.all;
use IEEE.STD_LOGIC_ARITH.all;
```

```
entity addmant is
    port(alessb: in STD_LOGIC;
          manta: in STD_LOGIC_VECTOR(23 downto 0);
          mantb: in STD_LOGIC_VECTOR(23 downto 0);
          shmant: in STD_LOGIC_VECTOR(23 downto 0);
          exp_pre: in STD_LOGIC_VECTOR(7 downto 0);
          fract: out STD_LOGIC_VECTOR(22 downto 0);
          exp: out STD_LOGIC_VECTOR(7 downto 0));
end;
```

```
architecture synth of addmant is
    signal addressult: STD_LOGIC_VECTOR(24 downto 0);
    signal addval: STD_LOGIC_VECTOR(23 downto 0);
begin
    addval <= mantb when alessb = '1' else manta;
    addressult <= ('0' & shmant) + addval;
    fract <= addressult(23 downto 1)
        when addressult(24) = '1'
        else addressult(22 downto 0);
    exp <= (exp_pre + 1)
        when addressult(24) = '1'
        else exp_pre;
```

```
end;
```

**Exercise 5.45**

---

(a) Figure on next page

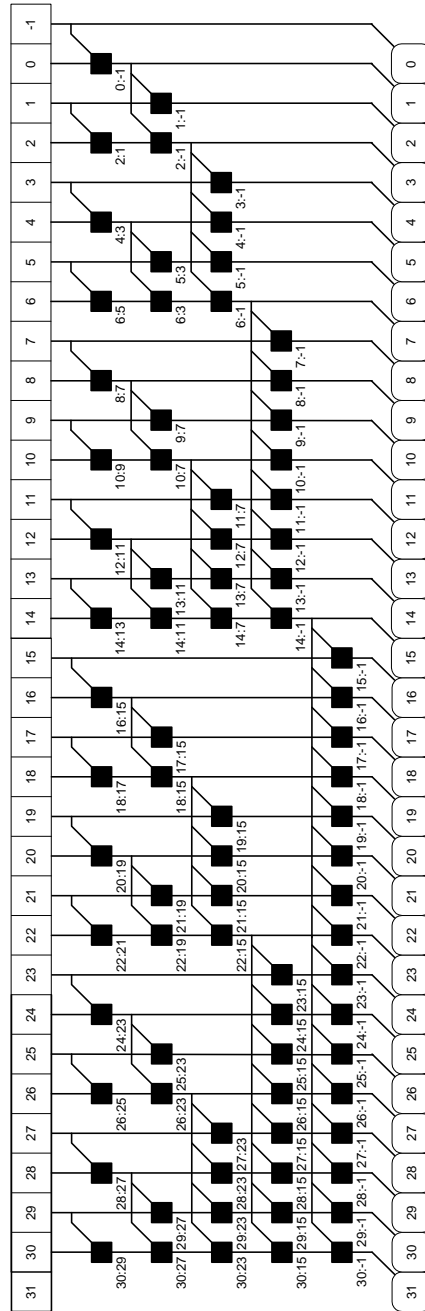

Row 1  
Row 2  
Row 3  
Row 4  
Row 5

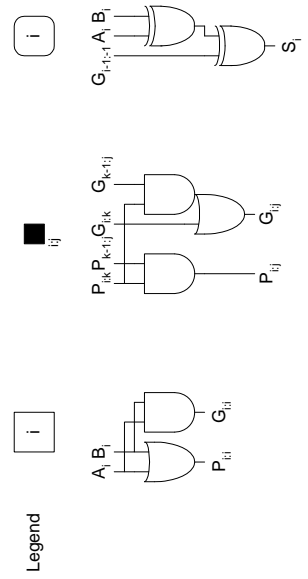

5.45 (b)

**SystemVerilog**

```

module prefixadd(input  logic [31:0] a, b,
                input  logic   cin,
                output logic [31:0] s,
                output logic   cout);

    logic [30:0] p, g;
    // p and g prefixes for rows 1 - 5
    logic [15:0] p1, p2, p3, p4, p5;
    logic [15:0] g1, g2, g3, g4, g5;

    pandg row0(a, b, p, g);
    blackbox row1({p[30],p[28],p[26],p[24],p[22],
                  p[20],p[18],p[16],p[14],p[12],
                  p[10],p[8],p[6],p[4],p[2],p[0]},
                 {p[29],p[27],p[25],p[23],p[21],
                  p[19],p[17],p[15],p[13],p[11],
                  p[9],p[7],p[5],p[3],p[1],1'b0},
                 {g[30],g[28],g[26],g[24],g[22],
                  g[20],g[18],g[16],g[14],g[12],
                  g[10],g[8],g[6],g[4],g[2],g[0]},
                 {g[29],g[27],g[25],g[23],g[21],
                  g[19],g[17],g[15],g[13],g[11],
                  g[9],g[7],g[5],g[3],g[1],cin},
                 p1, g1);

    pandg row0(a, b, p, g);
    blackbox row1({p[30],p[28],p[26],p[24],p[22],
                  p[20],p[18],p[16],p[14],p[12],
                  p[10],p[8],p[6],p[4],p[2],p[0]},
                 {p[29],p[27],p[25],p[23],p[21],
                  p[19],p[17],p[15],p[13],p[11],
                  p[9],p[7],p[5],p[3],p[1],1'b0},
                 {g[30],g[28],g[26],g[24],g[22],
                  g[20],g[18],g[16],g[14],g[12],
                  g[10],g[8],g[6],g[4],g[2],g[0]},
                 {g[29],g[27],g[25],g[23],g[21],
                  g[19],g[17],g[15],g[13],g[11],
                  g[9],g[7],g[5],g[3],g[1],cin},
                 p1, g1);
    
```

**VHDL**

```

library IEEE; use IEEE.STD_LOGIC_1164.all;

entity prefixadd is
    port(a, b: in  STD_LOGIC_VECTOR(31 downto 0);
          cin: in  STD_LOGIC;
          s: out  STD_LOGIC_VECTOR(31 downto 0);
          cout: out STD_LOGIC);
end;

architecture synth of prefixadd is
    component pgblock
        port(a, b: in  STD_LOGIC_VECTOR(30 downto 0);
              p, g: out STD_LOGIC_VECTOR(30 downto 0));
    end component;

    component pgblackblock is
        port (pik, gik: in  STD_LOGIC_VECTOR(15 downto 0);
              pkj, gkj: in  STD_LOGIC_VECTOR(15 downto 0);
              pij: out  STD_LOGIC_VECTOR(15 downto 0);
              gij: out  STD_LOGIC_VECTOR(15 downto 0));
    end component;

    component subblock is
        port (a, b, g: in  STD_LOGIC_VECTOR(31 downto 0);
              s: out  STD_LOGIC_VECTOR(31 downto 0));
    end component;

    signal p, g: STD_LOGIC_VECTOR(30 downto 0);
    signal pik_1, pik_2, pik_3, pik_4, pik_5,
           gik_1, gik_2, gik_3, gik_4, gik_5,
           pkj_1, pkj_2, pkj_3, pkj_4, pkj_5,
           gkj_1, gkj_2, gkj_3, gkj_4, gkj_5,
           p1, p2, p3, p4, p5,
           g1, g2, g3, g4, g5:
        STD_LOGIC_VECTOR(15 downto 0);
    signal g6: STD_LOGIC_VECTOR(31 downto 0);

begin
    row0: pgblock
        port map(a(30 downto 0), b(30 downto 0), p, g);

    pik_1 <=
        (p(30)&p(28)&p(26)&p(24)&p(22)&p(20)&p(18)&p(16)&
         p(14)&p(12)&p(10)&p(8)&p(6)&p(4)&p(2)&p(0));
    gik_1 <=
        (g(30)&g(28)&g(26)&g(24)&g(22)&g(20)&g(18)&g(16)&
         g(14)&g(12)&g(10)&g(8)&g(6)&g(4)&g(2)&g(0));
    pkj_1 <=
        (p(29)&p(27)&p(25)&p(23)&p(21)&p(19)&p(17)&p(15)&
         p(13)&p(11)&p(9)&p(7)&p(5)&p(3)&p(1)&'0');
    gkj_1 <=
        (g(29)&g(27)&g(25)&g(23)&g(21)&g(19)&g(17)&g(15)&
         g(13)&g(11)&g(9)&g(7)&g(5)& g(3)& g(1)& cin);

    row1: pgblackblock
        port map(pik_1, gik_1, pkj_1, gkj_1,
                p1, g1);
    
```

(continued from previous page)

**SystemVerilog**

**VHDL**

```

blackbox row2({p1[15],p[29],p1[13],p[25],p1[11],
  p[21],p1[9],p[17],p1[7],p[13],
  p1[5],p[9],p1[3],p[5],p1[1],p[1]},
  {{2{p1[14]}}, {2{p1[12]}}, {2{p1[10]}},
  {2{p1[8]}}, {2{p1[6]}}, {2{p1[4]}},
  {2{p1[2]}}, {2{p1[0]}}},
  {g1[15],g[29],g1[13],g[25],g1[11],
  g[21],g1[9],g[17],g1[7],g[13],
  g1[5],g[9],g1[3],g[5],g1[1],g[1]},
  {{2{g1[14]}}, {2{g1[12]}}, {2{g1[10]}},
  {2{g1[8]}}, {2{g1[6]}}, {2{g1[4]}},
  {2{g1[2]}}, {2{g1[0]}}},
  p2, g2);

blackbox row3({p2[15],p2[14],p1[14],p[27],p2[11],
  p2[10],p1[10],p[19],p2[7],p2[6],
  p1[6],p[11],p2[3],p2[2],p1[2],p[3]},
  {{4{p2[13]}}, {4{p2[9]}}, {4{p2[5]}},
  {4{p2[1]}},
  {g2[15],g2[14],g1[14],g[27],g2[11],
  g2[10],g1[10],g[19],g2[7],g2[6],
  g1[6],g[11],g2[3],g2[2],g1[2],g[3]},
  {{4{g2[13]}}, {4{g2[9]}}, {4{g2[5]}},
  {4{g2[1]}},
  p3, g3);

pik_2 <= p1(15)&p(29)&p1(13)&p(25)&p1(11)&
  p(21)&p1(9)&p(17)&p1(7)&p(13)&
  p1(5)&p(9)&p1(3)&p(5)&p1(1)&p(1);

gik_2 <= g1(15)&g(29)&g1(13)&g(25)&g1(11)&
  g(21)&g1(9)&g(17)&g1(7)&g(13)&
  g1(5)&g(9)&g1(3)&g(5)&g1(1)&g(1);

pkj_2 <=
  p1(14)&p1(14)&p1(12)&p1(12)&p1(10)&p1(10)&
  p1(8)&p1(8)&p1(6)&p1(6)&p1(4)&p1(4)&
  p1(2)&p1(2)&p1(0)&p1(0);

gkj_2 <=
  g1(14)&g1(14)&g1(12)&g1(12)&g1(10)&g1(10)&
  g1(8)&g1(8)&g1(6)&g1(6)&g1(4)&g1(4)&
  g1(2)&g1(2)&g1(0)&g1(0);

row2: pgblackblock
  port map(pik_2, gik_2, pkj_2, gkj_2,
    p2, g2);

pik_3 <= p2(15)&p2(14)&p1(14)&p(27)&p2(11)&
  p2(10)&p1(10)&p(19)&p2(7)&p2(6)&
  p1(6)&p(11)&p2(3)&p2(2)&p1(2)&p(3);

gik_3 <= g2(15)&g2(14)&g1(14)&g(27)&g2(11)&
  g2(10)&g1(10)&g(19)&g2(7)&g2(6)&
  g1(6)&g(11)&g2(3)&g2(2)&g1(2)&g(3);

pkj_3 <= p2(13)&p2(13)&p2(13)&p2(13)&
  p2(9)&p2(9)&p2(9)&p2(9)&
  p2(5)&p2(5)&p2(5)&p2(5)&
  p2(1)&p2(1)&p2(1)&p2(1);

gkj_3 <= g2(13)&g2(13)&g2(13)&g2(13)&
  g2(9)&g2(9)&g2(9)&g2(9)&
  g2(5)&g2(5)&g2(5)&g2(5)&
  g2(1)&g2(1)&g2(1)&g2(1);

row3: pgblackblock
  port map(pik_3, gik_3, pkj_3, gkj_3, p3, g3);

```

(continued on next page)



## SystemVerilog

```

    blackbox row4({p3[15:12],p2[13:12],
        p1[12],p[23],p3[7:4],
        p2[5:4],p1[4],p[7]},
        {{8{p3[11]}},{8{p3[3]}}},
        {g3[15:12],g2[13:12],
        g1[12],g[23],g3[7:4],
        g2[5:4],g1[4],g[7]},
        {{8{g3[11]}},{8{g3[3]}}},
        p4, g4);

    blackbox row5({p4[15:8],p3[11:8],p2[9:8],
        p1[8],p[15]},
        {{16{p4[7]}}},
        {g4[15:8],g3[11:8],g2[9:8],
        g1[8],g[15]},
        {{16{g4[7]}}},
        p5,g5);

    sum row6({g5,g4[7:0],g3[3:0],g2[1:0],g1[0],cin},
        a, b, s);

    // generate cout
    assign cout = (a[31] & b[31]) |
        (g5[15] & (a[31] | b[31]));
endmodule
    
```

## VHDL

```

    pik_4 <= p3(15 downto 12)&p2(13 downto 12)&
        p1(12)&p(23)&p3(7 downto 4)&
        p2(5 downto 4)&p1(4)&p(7);
    gik_4 <= g3(15 downto 12)&g2(13 downto 12)&
        g1(12)&g(23)&g3(7 downto 4)&
        g2(5 downto 4)&g1(4)&g(7);
    pkj_4 <= p3(11)&p3(11)&p3(11)&p3(11)&
        p3(11)&p3(11)&p3(11)&p3(11)&
        p3(3)&p3(3)&p3(3)&p3(3)&
        p3(3)&p3(3)&p3(3)&p3(3);
    gkj_4 <= g3(11)&g3(11)&g3(11)&g3(11)&
        g3(11)&g3(11)&g3(11)&g3(11)&
        g3(3)&g3(3)&g3(3)&g3(3)&
        g3(3)&g3(3)&g3(3)&g3(3);

    row4: pgblackblock
        port map(pik_4, gik_4, pkj_4, gkj_4, p4, g4);

    pik_5 <= p4(15 downto 8)&p3(11 downto 8)&
        p2(9 downto 8)&p1(8)&p(15);
    gik_5 <= g4(15 downto 8)&g3(11 downto 8)&
        g2(9 downto 8)&g1(8)&g(15);
    pkj_5 <= p4(7)&p4(7)&p4(7)&p4(7)&
        p4(7)&p4(7)&p4(7)&p4(7)&
        p4(7)&p4(7)&p4(7)&p4(7)&
        p4(7)&p4(7)&p4(7)&p4(7);
    gkj_5 <= g4(7)&g4(7)&g4(7)&g4(7)&
        g4(7)&g4(7)&g4(7)&g4(7)&
        g4(7)&g4(7)&g4(7)&g4(7)&
        g4(7)&g4(7)&g4(7)&g4(7);

    row5: pgblackblock
        port map(pik_5, gik_5, pkj_5, gkj_5, p5, g5);

    g6 <= (g5 & g4(7 downto 0) & g3(3 downto 0) &
        g2(1 downto 0) & g1(0) & cin);

    row6: sumblock
        port map(g6, a, b, s);

    -- generate cout
    cout <= (a(31) and b(31)) or
        (g6(31) and (a(31) or b(31)));

end;
    
```

(continued on next page)

*(continued from previous page)***SystemVerilog**

```

module pandg(input  logic [30:0] a, b,
             output logic [30:0] p, g);

    assign p = a | b;
    assign g = a & b;

endmodule

module blackbox(input  logic [15:0] pleft, pright,
                gleft, gright,
                output logic [15:0] pnext, gnext);

    assign pnext = pleft & pright;
    assign gnext = pleft & gright | gleft;
endmodule

module sum(input  logic [31:0] g, a, b,
           output logic [31:0] s);

    assign s = a ^ b ^ g;

endmodule

```

**VHDL**

```

library IEEE; use IEEE.STD_LOGIC_1164.all;

entity pgblock is
    port(a, b: in  STD_LOGIC_VECTOR(30 downto 0);
         p, g: out STD_LOGIC_VECTOR(30 downto 0));
end;

architecture synth of pgblock is
begin
    p <= a or b;
    g <= a and b;
end;

library IEEE; use IEEE.STD_LOGIC_1164.all;

entity pgblackblock is
    port(pik, gik, pkj, gkj:
         in  STD_LOGIC_VECTOR(15 downto 0);
         pij, gij:
         out STD_LOGIC_VECTOR(15 downto 0));
end;

architecture synth of pgblackblock is
begin
    pij <= pik and pkj;
    gij <= gik or (pik and gkj);
end;

library IEEE; use IEEE.STD_LOGIC_1164.all;

entity sumblock is
    port(g, a, b: in  STD_LOGIC_VECTOR(31 downto 0);
         s:      out STD_LOGIC_VECTOR(31 downto 0));
end;

architecture synth of sumblock is
begin
    s <= a xor b xor g;
end;

```

5.45 (c) Using Equation 5.11 to find the delay of the prefix adder:

$$t_{PA} = t_{pg} + \log_2 N(t_{pg\_prefix}) + t_{XOR}$$

We find the delays for each block:

$$t_{pg} = 100 \text{ ps}$$

$$t_{pg\_prefix} = 200 \text{ ps}$$

$$t_{XOR} = 100 \text{ ps}$$

Thus,

$$t_{PA} = [100 + 5(200) + 100] \text{ ps} = 1200 \text{ ps} = \mathbf{1.2 \text{ ns}}$$

5.45 (d) To make a pipelined prefix adder, add pipeline registers between each of the rows of the prefix adder. Now each stage will take 200 ps plus the

sequencing overhead,  $t_{pq} + t_{\text{setup}} = 80\text{ps}$ . Thus each cycle is 280 ps and the design can run at 3.57 GHz.

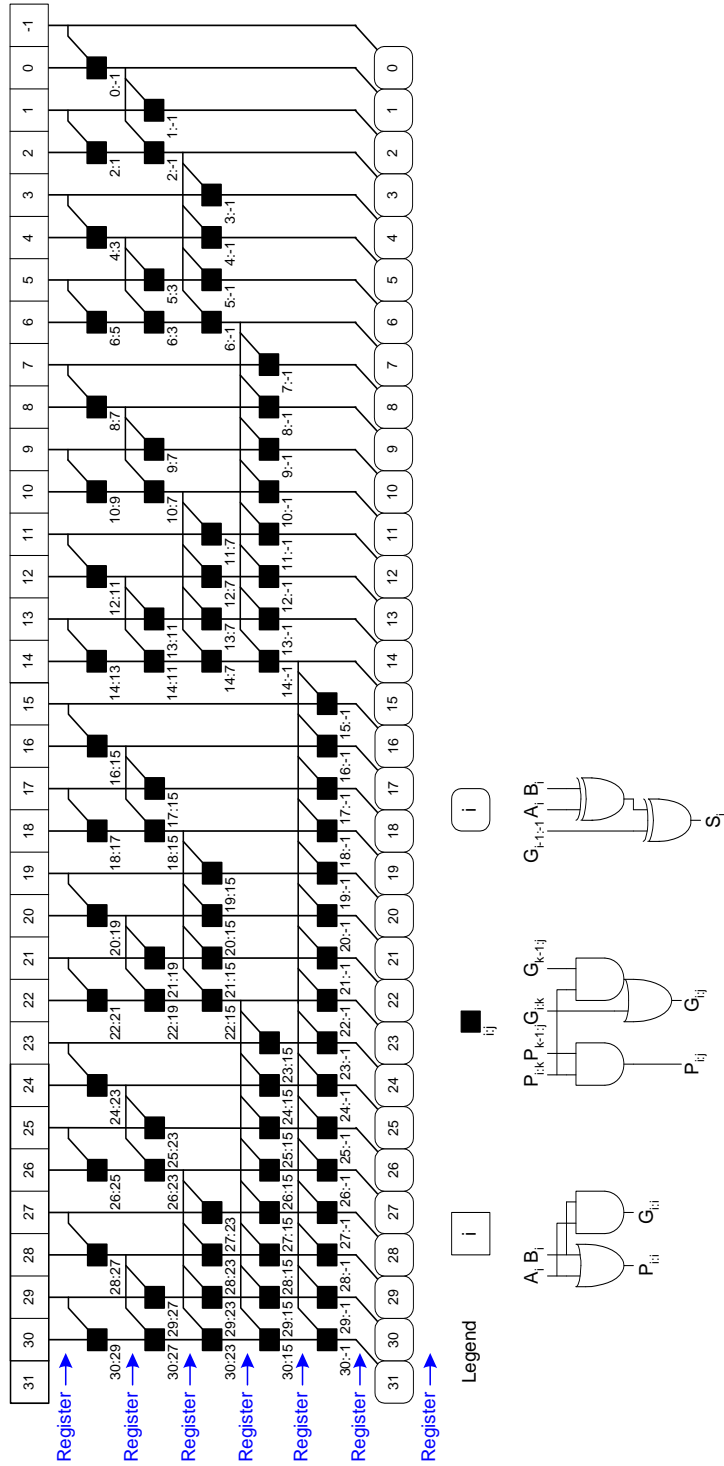

## 5.45 (e)

## SystemVerilog

```

module prefixaddpipe(input logic clk, cin,
                    input logic [31:0] a, b,
                    output logic [31:0] s, output cout);

    // p and g prefixes for rows 0 - 5
    logic [30:0] p0, p1, p2, p3, p4, p5;
    logic [30:0] g0, g1, g2, g3, g4, g5;
    logic p_1_0, p_1_1, p_1_2, p_1_3, p_1_4, p_1_5,
         g_1_0, g_1_1, g_1_2, g_1_3, g_1_4, g_1_5;

    // pipeline values for a and b
    logic [31:0] a0, a1, a2, a3, a4, a5,
                b0, b1, b2, b3, b4, b5;

    // row 0
    flop #(2) flop0_pg_1(clk, {1'b0,cin}, {p_1_0,g_1_0});
    pandg row0(clk, a[30:0], b[30:0], p0, g0);

    // row 1
    flop #(2) flop1_pg_1(clk, {p_1_0,g_1_0}, {p_1_1,g_1_1});
    flop #(30) flop1_pg(clk,
    {p0[29],p0[27],p0[25],p0[23],p0[21],p0[19],p0[17],p0[15],
     p0[13],p0[11],p0[9],p0[7],p0[5],p0[3],p0[1],
    g0[29],g0[27],g0[25],g0[23],g0[21],g0[19],g0[17],g0[15],
     g0[13],g0[11],g0[9],g0[7],g0[5],g0[3],g0[1]},
    {p1[29],p1[27],p1[25],p1[23],p1[21],p1[19],p1[17],p1[15],
     p1[13],p1[11],p1[9],p1[7],p1[5],p1[3],p1[1],
    g1[29],g1[27],g1[25],g1[23],g1[21],g1[19],g1[17],g1[15],
     g1[13],g1[11],g1[9],g1[7],g1[5],g1[3],g1[1]});

    blackbox row1(clk,
    {p0[30],p0[28],p0[26],p0[24],p0[22],
     p0[20],p0[18],p0[16],p0[14],p0[12],
     p0[10],p0[8],p0[6],p0[4],p0[2],p0[0]},
    {p0[29],p0[27],p0[25],p0[23],p0[21],
     p0[19],p0[17],p0[15],p0[13],p0[11],
     p0[9],p0[7],p0[5],p0[3],p0[1],1'b0},
    {g0[30],g0[28],g0[26],g0[24],g0[22],
     g0[20],g0[18],g0[16],g0[14],g0[12],
     g0[10],g0[8],g0[6],g0[4],g0[2],g0[0]},
    {g0[29],g0[27],g0[25],g0[23],g0[21],
     g0[19],g0[17],g0[15],g0[13],g0[11],
     g0[9],g0[7],g0[5],g0[3],g0[1],g_1_0},
    {p1[30],p1[28],p1[26],p1[24],p1[22],p1[20],
     p1[18],p1[16],p1[14],p1[12],p1[10],p1[8],
     p1[6],p1[4],p1[2],p1[0]},
    {g1[30],g1[28],g1[26],g1[24],g1[22],g1[20],
     g1[18],g1[16],g1[14],g1[12],g1[10],g1[8],
     g1[6],g1[4],g1[2],g1[0]});

    // row 2
    flop #(2) flop2_pg_1(clk, {p_1_1,g_1_1}, {p_1_2,g_1_2});
    flop #(30) flop2_pg(clk,
    {p1[28:27],p1[24:23],p1[20:19],p1[16:15],p1[12:11],

```

```

        p1[8:7],p1[4:3],p1[0],
g1[28:27],g1[24:23],g1[20:19],g1[16:15],g1[12:11],
g1[8:7],g1[4:3],g1[0]},
    {p2[28:27],p2[24:23],p2[20:19],p2[16:15],p2[12:11],
      p2[8:7],p2[4:3],p2[0]},
    g2[28:27],g2[24:23],g2[20:19],g2[16:15],g2[12:11],
    g2[8:7],g2[4:3],g2[0]};
    blackbox row2(clk,

{p1[30:29],p1[26:25],p1[22:21],p1[18:17],p1[14:13],p1[10:9],p1[6:5],p1[2:1]
},

    { {2{p1[28]}}, {2{p1[24]}}, {2{p1[20]}}, {2{p1[16]}}, {2{p1[12]}},
    {2{p1[8]}},
      {2{p1[4]}}, {2{p1[0]}} },

{g1[30:29],g1[26:25],g1[22:21],g1[18:17],g1[14:13],g1[10:9],g1[6:5],g1[2:1]
},

    { {2{g1[28]}}, {2{g1[24]}}, {2{g1[20]}}, {2{g1[16]}}, {2{g1[12]}},
    {2{g1[8]}},
      {2{g1[4]}}, {2{g1[0]}} },

{p2[30:29],p2[26:25],p2[22:21],p2[18:17],p2[14:13],p2[10:9],p2[6:5],p2[2:1]
},

{g2[30:29],g2[26:25],g2[22:21],g2[18:17],g2[14:13],g2[10:9],g2[6:5],g2[2:1]
} );

// row 3
flop #(2) flop3_pg_1(clk, {p_1_2,g_1_2}, {p_1_3,g_1_3});
flop #(30) flop3_pg(clk, {p2[26:23],p2[18:15],p2[10:7],p2[2:0]},
g2[26:23],g2[18:15],g2[10:7],g2[2:0]},
{p3[26:23],p3[18:15],p3[10:7],p3[2:0]},
g3[26:23],g3[18:15],g3[10:7],g3[2:0]};
    blackbox row3(clk,
        {p2[30:27],p2[22:19],p2[14:11],p2[6:3]},
    { {4{p2[26]}}, {4{p2[18]}}, {4{p2[10]}}, {4{p2[2]}} },
    {g2[30:27],g2[22:19],g2[14:11],g2[6:3]},
    { {4{g2[26]}}, {4{g2[18]}}, {4{g2[10]}}, {4{g2[2]}} },
    {p3[30:27],p3[22:19],p3[14:11],p3[6:3]},
    {g3[30:27],g3[22:19],g3[14:11],g3[6:3]});

// row 4
flop #(2) flop4_pg_1(clk, {p_1_3,g_1_3}, {p_1_4,g_1_4});
flop #(30) flop4_pg(clk, {p3[22:15],p3[6:0]},
g3[22:15],g3[6:0]},
        {p4[22:15],p4[6:0]},
g4[22:15],g4[6:0]});

    blackbox row4(clk,
        {p3[30:23],p3[14:7]},
    { {8{p3[22]}}, {8{p3[6]}} },
        {g3[30:23],g3[14:7]},
    { {8{g3[22]}}, {8{g3[6]}} },
    {p4[30:23],p4[14:7]},
    {g4[30:23],g4[14:7]});

// row 5
flop #(2) flop5_pg_1(clk, {p_1_4,g_1_4}, {p_1_5,g_1_5});
flop #(30) flop5_pg(clk, {p4[14:0],g4[14:0]},
        {p5[14:0],g5[14:0]});

```

```

    blackbox row5(clk,
                  p4[30:15],
                  {16{p4[14]}},
                  g4[30:15],
                  {16{g4[14]}},
                  p5[30:15], g5[30:15]);

    // pipeline registers for a and b
    flop #(64) flop0_ab(clk, {a,b}, {a0,b0});
    flop #(64) flop1_ab(clk, {a0,b0}, {a1,b1});
    flop #(64) flop2_ab(clk, {a1,b1}, {a2,b2});
    flop #(64) flop3_ab(clk, {a2,b2}, {a3,b3});
    flop #(64) flop4_ab(clk, {a3,b3}, {a4,b4});
    flop #(64) flop5_ab(clk, {a4,b4}, {a5,b5});

    sum row6(clk, {g5,g_1_5}, a5, b5, s);
    // generate cout
    assign cout = (a5[31] & b5[31]) | (g5[30] & (a5[31] | b5[31]));
endmodule

// submodules
module pandg(input logic clk,
             input logic [30:0] a, b,
             output logic [30:0] p, g);

    always_ff @(posedge clk)
    begin
        p <= a | b;
        g <= a & b;
    end

endmodule

module blackbox(input logic clk,
               input logic [15:0] pleft, pright, gleft, gright,
               output logic [15:0] pnext, gnext);

    always_ff @(posedge clk)
    begin
        pnext <= pleft & pright;
        gnext <= pleft & gright | gleft;
    end
endmodule

module sum(input logic clk,
           input logic [31:0] g, a, b,
           output logic [31:0] s);

    always_ff @(posedge clk)
        s <= a ^ b ^ g;
endmodule

module flop
    #(parameter width = 8)
    (input logic clk,
     input logic [width-1:0] d,
     output logic [width-1:0] q);

    always_ff @(posedge clk)
        q <= d;
endmodule

```



### 5.45 (e)

#### VHDL

```
library IEEE; use IEEE.STD_LOGIC_1164.all;

entity prefixaddpipe is
  port(clk: in STD_LOGIC;
        a, b: in STD_LOGIC_VECTOR(31 downto 0);
        cin: in STD_LOGIC;
        s: out STD_LOGIC_VECTOR(31 downto 0);
        cout: out STD_LOGIC);
end;

architecture synth of prefixaddpipe is
  component pgblock
    port(clk: in STD_LOGIC;
          a, b: in STD_LOGIC_VECTOR(30 downto 0);
          p, g: out STD_LOGIC_VECTOR(30 downto 0));
  end component;
  component subblock is
    port (clk: in STD_LOGIC;
          a, b, g: in STD_LOGIC_VECTOR(31 downto 0);
          s: out STD_LOGIC_VECTOR(31 downto 0));
  end component;
  component flop is generic(width: integer);
    port(clk: in STD_LOGIC;
          d: in STD_LOGIC_VECTOR(width-1 downto 0);
          q: out STD_LOGIC_VECTOR(width-1 downto 0));
  end component;
  component flopl is
    port(clk: in STD_LOGIC;
          d: in STD_LOGIC;
          q: out STD_LOGIC);
  end component;
  component row1 is
    port(clk: in STD_LOGIC;
          p0, g0: in STD_LOGIC_VECTOR(30 downto 0);
          p_1_0, g_1_0: in STD_LOGIC;
          p1, g1: out STD_LOGIC_VECTOR(30 downto 0));
  end component;
  component row2 is
    port(clk: in STD_LOGIC;
          p1, g1: in STD_LOGIC_VECTOR(30 downto 0);
          p2, g2: out STD_LOGIC_VECTOR(30 downto 0));
  end component;
  component row3 is
    port(clk: in STD_LOGIC;
          p2, g2: in STD_LOGIC_VECTOR(30 downto 0);
          p3, g3: out STD_LOGIC_VECTOR(30 downto 0));
  end component;
  component row4 is
    port(clk: in STD_LOGIC;
          p3, g3: in STD_LOGIC_VECTOR(30 downto 0);
          p4, g4: out STD_LOGIC_VECTOR(30 downto 0));
  end component;
  component row5 is
    port(clk: in STD_LOGIC;
          p4, g4: in STD_LOGIC_VECTOR(30 downto 0);
          p5, g5: out STD_LOGIC_VECTOR(30 downto 0));
  end component;
```

```

-- p and g prefixes for rows 0 - 5
signal p0, p1, p2, p3, p4, p5: STD_LOGIC_VECTOR(30 downto 0);
signal g0, g1, g2, g3, g4, g5: STD_LOGIC_VECTOR(30 downto 0);

-- p and g prefixes for column -1, rows 0 - 5
signal p_1_0, p_1_1, p_1_2, p_1_3, p_1_4, p_1_5,
       g_1_0, g_1_1, g_1_2, g_1_3, g_1_4, g_1_5: STD_LOGIC;

-- pipeline values for a and b
signal a0, a1, a2, a3, a4, a5,
       b0, b1, b2, b3, b4, b5: STD_LOGIC_VECTOR(31 downto 0);

-- final generate signal
signal g5_all: STD_LOGIC_VECTOR(31 downto 0);

begin

-- p and g calculations
row0_reg: pgblock port map(clk, a(30 downto 0), b(30 downto 0), p0, g0);
row1_reg: row1 port map(clk, g0, p_1_0, g_1_0, p1, g1);
row2_reg: row2 port map(clk, p1, g1, p2, g2);
row3_reg: row3 port map(clk, p2, g2, p3, g3);
row4_reg: row4 port map(clk, p3, g3, p4, g4);
row5_reg: row5 port map(clk, p4, g4, p5, g5);

-- pipeline registers for a and b
flop0_a: flop generic map(32) port map (clk, a, a0);
flop0_b: flop generic map(32) port map (clk, b, b0);
flop1_a: flop generic map(32) port map (clk, a0, a1);
flop1_b: flop generic map(32) port map (clk, b0, b1);
flop2_a: flop generic map(32) port map (clk, a1, a2);
flop2_b: flop generic map(32) port map (clk, b1, b2);
flop3_a: flop generic map(32) port map (clk, a2, a3);
flop3_b: flop generic map(32) port map (clk, b2, b3);
flop4_a: flop generic map(32) port map (clk, a3, a4);
flop4_b: flop generic map(32) port map (clk, b3, b4);
flop5_a: flop generic map(32) port map (clk, a4, a5);
flop5_b: flop generic map(32) port map (clk, b4, b5);

-- pipeline p and g for column -1
p_1_0 <= '0'; flop1_g0: flop1 port map (clk, cin, g_1_0);
flop1_p1: flop1 port map (clk, p_1_0, p_1_1);
flop1_g1: flop1 port map (clk, g_1_0, g_1_1);
flop1_p2: flop1 port map (clk, p_1_1, p_1_2);
flop1_g2: flop1 port map (clk, g_1_1, g_1_2);
flop1_p3: flop1 port map (clk, p_1_2, p_1_3); flop1_g3:
flop1 port map (clk, g_1_2, g_1_3);
flop1_p4: flop1 port map (clk, p_1_3, p_1_4);
flop1_g4: flop1 port map (clk, g_1_3, g_1_4);
flop1_p5: flop1 port map (clk, p_1_4, p_1_5);
flop1_g5: flop1 port map (clk, g_1_4, g_1_5);

-- generate sum and cout
g5_all <= (g5&g_1_5);
row6: subblock port map(clk, g5_all, a5, b5, s);

-- generate cout
cout <= (a5(31) and b5(31)) or (g5(30) and (a5(31) or b5(31)));
end;

library IEEE; use IEEE.STD_LOGIC_1164.all;
entity pgblock is
  port(clk: in STD_LOGIC;

```

```
        a, b: in  STD_LOGIC_VECTOR(30 downto 0);
        p, g: out STD_LOGIC_VECTOR(30 downto 0));
end;

architecture synth of pgblock is
begin
    process(clk) begin
        if rising_edge(clk) then
            p <= a or b;
            g <= a and b;
        end if;
    end process;
end;

library IEEE; use IEEE.STD_LOGIC_1164.all;

entity blackbox is
    port(clk: in  STD_LOGIC;
          pik, pkj, gik, gkj:
            in  STD_LOGIC_VECTOR(15 downto 0);
          pij, gij:
            out STD_LOGIC_VECTOR(15 downto 0));
end;

architecture synth of blackbox is
begin
    process(clk) begin
        if rising_edge(clk) then
            pij <= pik and pkj;
            gij <= gik or (pik and gkj);
        end if;
    end process;
end;

library IEEE; use IEEE.STD_LOGIC_1164.all;

entity sumblock is
    port(clk: in  STD_LOGIC;
          g, a, b: in  STD_LOGIC_VECTOR(31 downto 0);
          s:      out STD_LOGIC_VECTOR(31 downto 0));
end;

architecture synth of sumblock is
begin
    process(clk) begin
        if rising_edge(clk) then
            s <= a xor b xor g;
        end if;
    end process;
end;

library IEEE; use IEEE.STD_LOGIC_1164.all; use IEEE.STD_LOGIC_ARITH.all;
entity flop is -- parameterizable flip flop
    generic(width: integer);
    port(clk: in  STD_LOGIC;
          d:   in  STD_LOGIC_VECTOR(width-1 downto 0);
          q:   out STD_LOGIC_VECTOR(width-1 downto 0));
end;

architecture synth of flop is
begin
    process(clk) begin
        if rising_edge(clk) then
            q <= d;
        end if;
    end process;
end;
```

```

        end if;
    end process;
end;

library IEEE; use IEEE.STD_LOGIC_1164.all; use IEEE.STD_LOGIC_ARITH.all;
entity flop1 is -- 1-bit flip flop
    port(clk:      in  STD_LOGIC;
          d:       in  STD_LOGIC;
          q:       out STD_LOGIC);
end;

architecture synth of flop1 is
begin
    process(clk) begin
        if rising_edge(clk) then
            q <= d;
        end if;
    end process;
end;

library IEEE; use IEEE.STD_LOGIC_1164.all;

entity row1 is
    port(clk:      in  STD_LOGIC;
          p0, g0:  in  STD_LOGIC_VECTOR(30 downto 0);
          p_l_0, g_l_0: in STD_LOGIC;
          pl, gl:  out STD_LOGIC_VECTOR(30 downto 0));
end;

architecture synth of row1 is
    component blackbox is
        port (clk:      in  STD_LOGIC;
              pik, pkj: in  STD_LOGIC_VECTOR(15 downto 0);
              gik, gkj: in  STD_LOGIC_VECTOR(15 downto 0);
              pij:     out STD_LOGIC_VECTOR(15 downto 0);
              gij:     out STD_LOGIC_VECTOR(15 downto 0));
    end component;
    component flop is generic(width: integer);
        port(clk: in  STD_LOGIC;
              d:  in  STD_LOGIC_VECTOR(width-1 downto 0);
              q:  out STD_LOGIC_VECTOR(width-1 downto 0));
    end component;

    -- internal signals for calculating p, g
    signal pik_0, gik_0, pkj_0, gkj_0,
           pij_0, gij_0: STD_LOGIC_VECTOR(15 downto 0);

    -- internal signals for pipeline registers
    signal pg0_in, pgl_out: STD_LOGIC_VECTOR(29 downto 0);

begin
    pg0_in <= (p0(29)&p0(27)&p0(25)&p0(23)&p0(21)&p0(19)&p0(17)&p0(15)&
              p0(13)&p0(11)&p0(9)&p0(7)&p0(5)&p0(3)&p0(1)&
              g0(29)&g0(27)&g0(25)&g0(23)&g0(21)&g0(19)&g0(17)&g0(15)&
              g0(13)&g0(11)&g0(9)&g0(7)&g0(5)&g0(3)&g0(1));
    flop1_pg: flop generic map(30) port map (clk, pg0_in, pgl_out);

    pl(29) <= pgl_out(29); pl(27) <= pgl_out(28); pl(25) <= pgl_out(27);
    pl(23) <= pgl_out(26);
    pl(21) <= pgl_out(25); pl(19) <= pgl_out(24); pl(17) <= pgl_out(23);
    pl(15) <= pgl_out(22); pl(13) <= pgl_out(21); pl(11) <= pgl_out(20);
    pl(9) <= pgl_out(19); pl(7) <= pgl_out(18); pl(5) <= pgl_out(17);
    pl(3) <= pgl_out(16); pl(1) <= pgl_out(15);
    gl(29) <= pgl_out(14); gl(27) <= pgl_out(13); gl(25) <= pgl_out(12);
    gl(23) <= pgl_out(11); gl(21) <= pgl_out(10); gl(19) <= pgl_out(9);
    gl(17) <= pgl_out(8); gl(15) <= pgl_out(7); gl(13) <= pgl_out(6);

```

```

g1(11) <= pg1_out(5); g1(9) <= pg1_out(4); g1(7) <= pg1_out(3);
g1(5) <= pg1_out(2); g1(3) <= pg1_out(1); g1(1) <= pg1_out(0);

-- pg calculations
pik_0 <= (p0(30)&p0(28)&p0(26)&p0(24)&p0(22)&p0(20)&p0(18)&p0(16)&
p0(14)&p0(12)&p0(10)&p0(8)&p0(6)&p0(4)&p0(2)&p0(0));
gik_0 <= (g0(30)&g0(28)&g0(26)&g0(24)&g0(22)&g0(20)&g0(18)&g0(16)&
g0(14)&g0(12)&g0(10)&g0(8)&g0(6)&g0(4)&g0(2)&g0(0));
pkj_0 <= (p0(29)&p0(27)&p0(25)&p0(23)&p0(21)&p0(19)&p0(17)&p0(15)&
p0(13)&p0(11)&p0(9)&p0(7)&p0(5)&p0(3)&p0(1)&p_1_0);
gkj_0 <= (g0(29)&g0(27)&g0(25)&g0(23)&g0(21)&g0(19)&g0(17)&g0(15)&
g0(13)&g0(11)&g0(9)&g0(7)&g0(5)&g0(3)&g0(1)&g_1_0);

row1: blackbox port map(clk, pik_0, pkj_0, gik_0, gkj_0, pij_0, gij_0);

p1(30) <= pij_0(15); p1(28) <= pij_0(14); p1(26) <= pij_0(13);
p1(24) <= pij_0(12); p1(22) <= pij_0(11); p1(20) <= pij_0(10);
p1(18) <= pij_0(9); p1(16) <= pij_0(8); p1(14) <= pij_0(7);
p1(12) <= pij_0(6); p1(10) <= pij_0(5); p1(8) <= pij_0(4);
p1(6) <= pij_0(3); p1(4) <= pij_0(2); p1(2) <= pij_0(1); p1(0) <= pij_0(0);

g1(30) <= gij_0(15); g1(28) <= gij_0(14); g1(26) <= gij_0(13);
g1(24) <= gij_0(12); g1(22) <= gij_0(11); g1(20) <= gij_0(10);
g1(18) <= gij_0(9); g1(16) <= gij_0(8); g1(14) <= gij_0(7);
g1(12) <= gij_0(6); g1(10) <= gij_0(5); g1(8) <= gij_0(4);
g1(6) <= gij_0(3); g1(4) <= gij_0(2); g1(2) <= gij_0(1); g1(0) <= gij_0(0);
end;

library IEEE; use IEEE.STD_LOGIC_1164.all;

entity row2 is
    port(clk: in STD_LOGIC;
          p1, g1: in STD_LOGIC_VECTOR(30 downto 0);
          p2, g2: out STD_LOGIC_VECTOR(30 downto 0));
end;

architecture synth of row2 is
    component blackbox is
        port (clk: in STD_LOGIC;
              pik, pkj: in STD_LOGIC_VECTOR(15 downto 0);
              gik, gkj: in STD_LOGIC_VECTOR(15 downto 0);
              pij: out STD_LOGIC_VECTOR(15 downto 0);
              gij: out STD_LOGIC_VECTOR(15 downto 0));
    end component;
    component flop is generic(width: integer);
        port(clk: in STD_LOGIC;
              d: in STD_LOGIC_VECTOR(width-1 downto 0);
              q: out STD_LOGIC_VECTOR(width-1 downto 0));
    end component;

    -- internal signals for calculating p, g
    signal pik_1, gik_1, pkj_1, gkj_1,
           pij_1, gij_1: STD_LOGIC_VECTOR(15 downto 0);

    -- internal signals for pipeline registers
    signal pg1_in, pg2_out: STD_LOGIC_VECTOR(29 downto 0);

begin
    pg1_in <= (p1(28 downto 27)&p1(24 downto 23)&p1(20 downto 19)&
p1(16 downto 15)&
p1(12 downto 11)&p1(8 downto 7)&p1(4 downto 3)&p1(0)&
g1(28 downto 27)&g1(24 downto 23)&g1(20 downto 19)&
g1(16 downto 15)&
g1(12 downto 11)&g1(8 downto 7)&g1(4 downto 3)&g1(0));
    flop2_pg: flop generic map(30) port map (clk, pg1_in, pg2_out);

```

```

p2(28 downto 27) <= pg2_out(29 downto 28);
p2(24 downto 23) <= pg2_out(27 downto 26);
p2(20 downto 19) <= pg2_out(25 downto 24);
p2(16 downto 15) <= pg2_out(23 downto 22);
p2(12 downto 11) <= pg2_out(21 downto 20);
p2(8 downto 7) <= pg2_out(19 downto 18);
p2(4 downto 3) <= pg2_out(17 downto 16);
p2(0) <= pg2_out(15);
g2(28 downto 27) <= pg2_out(14 downto 13);
g2(24 downto 23) <= pg2_out(12 downto 11);
g2(20 downto 19) <= pg2_out(10 downto 9);
g2(16 downto 15) <= pg2_out(8 downto 7);
g2(12 downto 11) <= pg2_out(6 downto 5);
g2(8 downto 7) <= pg2_out(4 downto 3);
g2(4 downto 3) <= pg2_out(2 downto 1); g2(0) <= pg2_out(0);

-- pg calculations
pik_1 <= (p1(30 downto 29)&p1(26 downto 25)&p1(22 downto 21)&
         p1(18 downto 17)&p1(14 downto 13)&p1(10 downto 9)&
         p1(6 downto 5)&p1(2 downto 1));
gik_1 <= (g1(30 downto 29)&g1(26 downto 25)&g1(22 downto 21)&
         g1(18 downto 17)&g1(14 downto 13)&g1(10 downto 9)&
         g1(6 downto 5)&g1(2 downto 1));
pkj_1 <= (p1(28)&p1(28)&p1(24)&p1(24)&p1(20)&p1(20)&p1(16)&p1(16)&
         p1(12)&p1(12)&p1(8)&p1(8)&p1(4)&p1(4)&p1(0)&p1(0));
gkj_1 <= (g1(28)&g1(28)&g1(24)&g1(24)&g1(20)&g1(20)&g1(16)&g1(16)&
         g1(12)&g1(12)&g1(8)&g1(8)&g1(4)&g1(4)&g1(0)&g1(0));

row2: blackbox
    port map(clk, pik_1, pkj_1, gik_1, gkj_1, pij_1, gij_1);

p2(30 downto 29) <= pij_1(15 downto 14);
p2(26 downto 25) <= pij_1(13 downto 12);
p2(22 downto 21) <= pij_1(11 downto 10);
p2(18 downto 17) <= pij_1(9 downto 8);
p2(14 downto 13) <= pij_1(7 downto 6); p2(10 downto 9) <= pij_1(5 downto 4);
p2(6 downto 5) <= pij_1(3 downto 2); p2(2 downto 1) <= pij_1(1 downto 0);

g2(30 downto 29) <= gij_1(15 downto 14);
g2(26 downto 25) <= gij_1(13 downto 12);
g2(22 downto 21) <= gij_1(11 downto 10);
g2(18 downto 17) <= gij_1(9 downto 8);
g2(14 downto 13) <= gij_1(7 downto 6); g2(10 downto 9) <= gij_1(5 downto 4);
g2(6 downto 5) <= gij_1(3 downto 2); g2(2 downto 1) <= gij_1(1 downto 0);

end;

library IEEE; use IEEE.STD_LOGIC_1164.all;

entity row3 is
    port(clk: in STD_LOGIC;
          p2, g2: in STD_LOGIC_VECTOR(30 downto 0);
          p3, g3: out STD_LOGIC_VECTOR(30 downto 0));
end;

architecture synth of row3 is
    component blackbox is
        port (clk: in STD_LOGIC;
              pik, pkj: in STD_LOGIC_VECTOR(15 downto 0);
              gik, gkj: in STD_LOGIC_VECTOR(15 downto 0);
              pij: out STD_LOGIC_VECTOR(15 downto 0);
              gij: out STD_LOGIC_VECTOR(15 downto 0));
    end component;
    component flop is generic(width: integer);
        port(clk: in STD_LOGIC;
              d: in STD_LOGIC_VECTOR(width-1 downto 0);

```

```
        q: out STD_LOGIC_VECTOR(width-1 downto 0));
end component;

-- internal signals for calculating p, g
signal pik_2, gik_2, pkj_2, gkj_2,
       pij_2, gij_2: STD_LOGIC_VECTOR(15 downto 0);

-- internal signals for pipeline registers
signal pg2_in, pg3_out: STD_LOGIC_VECTOR(29 downto 0);

begin
pg2_in <= (p2(26 downto 23)&p2(18 downto 15)&p2(10 downto 7)&
          p2(2 downto 0)&
          g2(26 downto 23)&g2(18 downto 15)&g2(10 downto 7)&g2(2 downto 0));
flop3_pg: flop generic map(30) port map (clk, pg2_in, pg3_out);
p3(26 downto 23) <= pg3_out(29 downto 26);
p3(18 downto 15) <= pg3_out(25 downto 22);
p3(10 downto 7) <= pg3_out(21 downto 18);
p3(2 downto 0) <= pg3_out(17 downto 15);
g3(26 downto 23) <= pg3_out(14 downto 11);
g3(18 downto 15) <= pg3_out(10 downto 7);
g3(10 downto 7) <= pg3_out(6 downto 3);
g3(2 downto 0) <= pg3_out(2 downto 0);

-- pg calculations
pik_2 <= (p2(30 downto 27)&p2(22 downto 19)&
          p2(14 downto 11)&p2(6 downto 3));
gik_2 <= (g2(30 downto 27)&g2(22 downto 19)&
          g2(14 downto 11)&g2(6 downto 3));
pkj_2 <= (p2(26)&p2(26)&p2(26)&p2(26)&
          p2(18)&p2(18)&p2(18)&p2(18)&
          p2(10)&p2(10)&p2(10)&p2(10)&
          p2(2)&p2(2)&p2(2)&p2(2));
gkj_2 <= (g2(26)&g2(26)&g2(26)&g2(26)&
          g2(18)&g2(18)&g2(18)&g2(18)&
          g2(10)&g2(10)&g2(10)&g2(10)&
          g2(2)&g2(2)&g2(2)&g2(2));

row3: blackbox
port map(clk, pik_2, pkj_2, gik_2, gkj_2, pij_2, gij_2);

p3(30 downto 27) <= pij_2(15 downto 12);
p3(22 downto 19) <= pij_2(11 downto 8);
p3(14 downto 11) <= pij_2(7 downto 4); p3(6 downto 3) <= pij_2(3 downto 0);
g3(30 downto 27) <= gij_2(15 downto 12);
g3(22 downto 19) <= gij_2(11 downto 8);
g3(14 downto 11) <= gij_2(7 downto 4); g3(6 downto 3) <= gij_2(3 downto 0);

end;

library IEEE; use IEEE.STD_LOGIC_1164.all;

entity row4 is
port(clk: in STD_LOGIC;
      p3, g3: in STD_LOGIC_VECTOR(30 downto 0);
      p4, g4: out STD_LOGIC_VECTOR(30 downto 0));
end;

architecture synth of row4 is
component blackbox is
port (clk: in STD_LOGIC;
      pik, pkj: in STD_LOGIC_VECTOR(15 downto 0);
      gik, gkj: in STD_LOGIC_VECTOR(15 downto 0);
      pij: out STD_LOGIC_VECTOR(15 downto 0);
      gij: out STD_LOGIC_VECTOR(15 downto 0));
end component;
```

```

component flop is generic(width: integer);
  port(clk: in STD_LOGIC;
        d: in STD_LOGIC_VECTOR(width-1 downto 0);
        q: out STD_LOGIC_VECTOR(width-1 downto 0));
end component;

-- internal signals for calculating p, g
signal pik_3, gik_3, pkj_3, gkj_3,
      pij_3, gij_3: STD_LOGIC_VECTOR(15 downto 0);

-- internal signals for pipeline registers
signal pg3_in, pg4_out: STD_LOGIC_VECTOR(29 downto 0);

begin
  pg3_in <= (p3(22 downto 15)&p3(6 downto 0)&g3(22 downto 15)&g3(6 downto 0));
  flop4_pg: flop generic map(30) port map (clk, pg3_in, pg4_out);
  p4(22 downto 15) <= pg4_out(29 downto 22);
  p4(6 downto 0) <= pg4_out(21 downto 15);
  g4(22 downto 15) <= pg4_out(14 downto 7);
  g4(6 downto 0) <= pg4_out(6 downto 0);

  -- pg calculations
  pik_3 <= (p3(30 downto 23)&p3(14 downto 7));
  gik_3 <= (g3(30 downto 23)&g3(14 downto 7));
  pkj_3 <= (p3(22)&p3(22)&p3(22)&p3(22)&p3(22)&p3(22)&p3(22)&p3(22)&
    p3(6)&p3(6)&p3(6)&p3(6)&p3(6)&p3(6)&p3(6)&p3(6));
  gkj_3 <= (g3(22)&g3(22)&g3(22)&g3(22)&g3(22)&g3(22)&g3(22)&g3(22)&
    g3(6)&g3(6)&g3(6)&g3(6)&g3(6)&g3(6)&g3(6)&g3(6));

  row4: blackbox
    port map(clk, pik_3, pkj_3, gik_3, gkj_3, pij_3, gij_3);

  p4(30 downto 23) <= pij_3(15 downto 8);
  p4(14 downto 7) <= pij_3(7 downto 0);
  g4(30 downto 23) <= gij_3(15 downto 8);
  g4(14 downto 7) <= gij_3(7 downto 0);

end;

library IEEE; use IEEE.STD_LOGIC_1164.all;

entity row5 is
  port(clk: in STD_LOGIC;
        p4, g4: in STD_LOGIC_VECTOR(30 downto 0);
        p5, g5: out STD_LOGIC_VECTOR(30 downto 0));
end;

architecture synth of row5 is
  component blackbox is
    port (clk: in STD_LOGIC;
          pik, pkj: in STD_LOGIC_VECTOR(15 downto 0);
          gik, gkj: in STD_LOGIC_VECTOR(15 downto 0);
          pij: out STD_LOGIC_VECTOR(15 downto 0);
          gij: out STD_LOGIC_VECTOR(15 downto 0));
  end component;
  component flop is generic(width: integer);
    port(clk: in STD_LOGIC;
          d: in STD_LOGIC_VECTOR(width-1 downto 0);
          q: out STD_LOGIC_VECTOR(width-1 downto 0));
  end component;

  -- internal signals for calculating p, g
  signal pik_4, gik_4, pkj_4, gkj_4,
        pij_4, gij_4: STD_LOGIC_VECTOR(15 downto 0);

  -- internal signals for pipeline registers
  signal pg4_in, pg5_out: STD_LOGIC_VECTOR(29 downto 0);

```



```

begin

    pg4_in <= (p4(14 downto 0)&g4(14 downto 0));
    flop4_pg: flop generic map(30) port map (clk, pg4_in, pg5_out);
    p5(14 downto 0) <= pg5_out(29 downto 15); g5(14 downto 0) <= pg5_out(14
    downto 0);

    -- pg calculations
    pik_4 <= p4(30 downto 15);
    gik_4 <= g4(30 downto 15);
    pkj_4 <= p4(14)&p4(14)&p4(14)&p4(14)&
        p4(14)&p4(14)&p4(14)&p4(14)&
        p4(14)&p4(14)&p4(14)&p4(14)&
        p4(14)&p4(14)&p4(14)&p4(14);
    gkj_4 <= g4(14)&g4(14)&g4(14)&g4(14)&
        g4(14)&g4(14)&g4(14)&g4(14)&
        g4(14)&g4(14)&g4(14)&g4(14)&
        g4(14)&g4(14)&g4(14)&g4(14);

    row5: blackbox
        port map(clk, pik_4, gik_4, pkj_4, gkj_4, pij_4, gij_4);
        p5(30 downto 15) <= pij_4; g5(30 downto 15) <= gij_4;

end;
```

**Exercise 5.47**

---

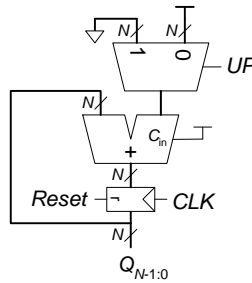

FIGURE 5.7 Up/Down counter

**Exercise 5.49**

---

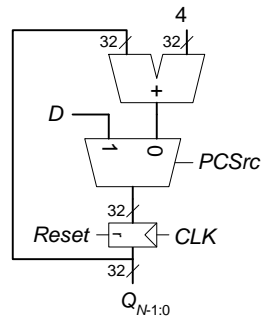

FIGURE 5.8 32-bit counter that increments by 4 or loads a new value,  $D$

### Exercise 5.11

#### SystemVerilog

```

module scanflop4(input  logic      clk, test, sin,
                input  logic [3:0] d,
                output logic [3:0] q,
                output logic      sout);

    always_ff @(posedge clk)
        if (test)
            q <= d;
        else
            q <= {q[2:0], sin};

    assign sout = q[3];
endmodule

```

#### VHDL

```

library IEEE; use IEEE.STD_LOGIC_1164.all;

entity scanflop4 is
    port(clk, test, sin: in STD_LOGIC;
         d: in STD_LOGIC_VECTOR(3 downto 0);
         q: inout STD_LOGIC_VECTOR(3 downto 0);
         sout: out STD_LOGIC);
end;

architecture synth of scanflop4 is
begin
    process(clk, test) begin
        if rising_edge(clk) then
            if test then
                q <= d;
            else
                q <= q(2 downto 0) & sin;
            end if;
        end if;
    end process;

    sout <= q(3);
end;

```

### Exercise 5.53

<http://www.intel.com/design/flash/articles/what.htm>

Flash memory is a nonvolatile memory because it retains its contents after power is turned off. Flash memory allows the user to electrically program and erase information. Flash memory uses memory cells similar to an EEPROM, but with a much thinner, precisely grown oxide between a floating gate and the substrate (see Figure 5.9).

Flash programming occurs when electrons are placed on the floating gate. This is done by forcing a large voltage (usually 10 to 12 volts) on the control gate. Electrons quantum-mechanically tunnel from the source through the thin oxide onto the control gate. Because the floating gate is completely insulated by oxide, the charges are trapped on the floating gate during normal operation. If electrons are stored on the floating gate, it blocks the effect of the control gate. The electrons on the floating gate can be removed by reversing the procedure, i.e., by placing a large negative voltage on the control gate.

The default state of a flash bitcell (when there are no electrons on the floating gate) is ON, because the channel will conduct when the wordline is HIGH. After the bitcell is programmed (i.e., when there are electrons on the floating gate), the state of the bitcell is OFF, because the floating gate blocks the effect of the control gate. Flash memory is a key element in thumb drives, cell phones, digital cameras, Blackberries, and other low-power devices that must retain their memory when turned off.

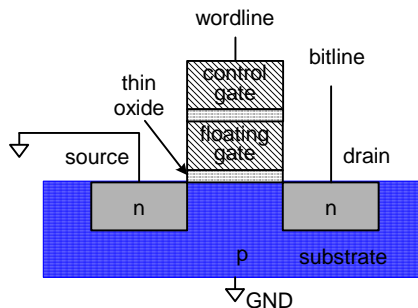
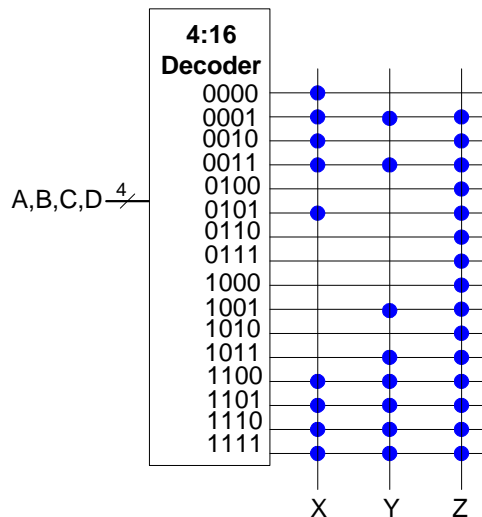

FIGURE 5.9 Flash EEPROM

**Exercise 5.55**

---



**Exercise 5.57**

---

- (a) Number of inputs =  $2 \times 16 + 1 = 33$   
 Number of outputs =  $16 + 1 = 17$

Thus, this would require a  $2^{33} \times 17$ -bit ROM.

- (b) Number of inputs = 16  
 Number of outputs = 16

Thus, this would require a  $2^{16} \times 16$ -bit ROM.

- (c) Number of inputs = 16  
 Number of outputs = 4

Thus, this would require a  $2^{16} \times 4$ -bit ROM.

All of these implementations are not good design choices. They could all be implemented in a smaller amount of hardware using discrete gates.

**Exercise 5.59**

(a) 1 LE

(A) data 1	(B) data 2	(C) data 3	(D) data 4	(Y) LUT output
0	0	0	0	1
0	0	0	1	1
0	0	1	0	1
0	0	1	1	1
0	1	0	0	1
0	1	0	1	1
0	1	1	0	1
0	1	1	1	1
1	0	0	0	1
1	0	0	1	1
1	0	1	0	1
1	0	1	1	0
1	1	0	0	0
1	1	0	1	1
1	1	1	0	0
1	1	1	1	1

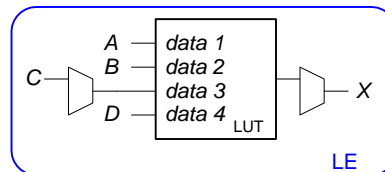

(b) 2 LEs

(B) data 1	(C) data 2	(D) data 3	(E) data 4	(X) LUT output
0	0	0	0	1
0	0	0	1	1
0	0	1	0	1
0	0	1	1	1
0	1	0	0	1
0	1	0	1	0
0	1	1	0	0
0	1	1	1	0
1	0	0	0	1
1	0	0	1	0
1	0	1	0	0
1	0	1	1	0
1	1	0	0	1
1	1	0	1	0
1	1	1	0	0
1	1	1	1	0

(A) data 1	(X) data 2	data 3	data 4	(Y) LUT output
0	0	X	X	0
0	1	X	X	1
1	0	X	X	1
1	1	X	X	1

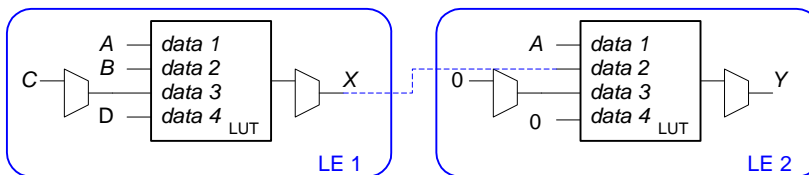

(c) 2 LEs

(A)	(B)	(C)	(D)	(Y)	(A)	(B)	(C)	(D)	(Z)
<i>data 1</i>	<i>data 2</i>	<i>data 3</i>	<i>data 4</i>	LUT output	<i>data 1</i>	<i>data 2</i>	<i>data 3</i>	<i>data 4</i>	LUT output
0	0	0	0	0	0	0	0	0	0
0	0	0	1	1	0	0	0	1	1
0	0	1	0	0	0	0	1	0	0
0	0	1	1	1	0	0	1	1	0
0	1	0	0	0	0	1	0	0	0
0	1	0	1	1	0	1	0	1	1
0	1	1	0	0	0	1	1	0	0
0	1	1	1	1	0	1	1	1	1
1	0	0	0	0	1	0	0	0	0
1	0	0	1	1	1	0	0	1	1
1	0	1	0	1	1	0	1	0	0
1	0	1	1	1	1	0	1	1	0
1	1	0	0	0	1	1	0	0	0
1	1	0	1	1	1	1	0	1	1
1	1	1	0	1	1	1	1	0	1
1	1	1	0	0	1	1	1	0	0
1	1	1	1	1	1	1	1	1	1

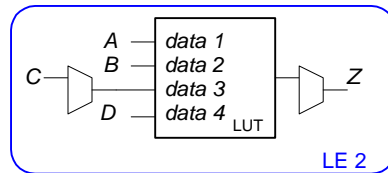
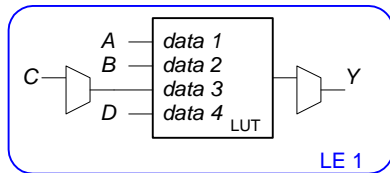

(d) 2 LEs

(A <sub>3</sub> ) data 1	(A <sub>2</sub> ) data 2	(A <sub>1</sub> ) data 3	(A <sub>0</sub> ) data 4	(D) LUT output	(A <sub>3</sub> ) data 1	(A <sub>2</sub> ) data 2	(A <sub>1</sub> ) data 3	(A <sub>0</sub> ) data 4	(P) LUT output
0	0	0	0	0	0	0	0	0	0
0	0	0	1	0	0	0	0	1	0
0	0	1	0	0	0	0	1	0	1
0	0	1	1	1	0	0	1	1	1
0	1	0	0	0	0	1	0	0	0
0	1	0	1	0	0	1	0	1	1
0	1	1	0	1	0	1	1	0	0
0	1	1	1	0	0	1	1	1	1
1	0	0	0	0	1	0	0	0	0
1	0	0	1	1	1	0	0	1	0
1	0	1	0	0	1	0	1	0	0
1	0	1	1	0	1	0	1	1	1
1	1	0	0	1	1	1	0	0	0
1	1	0	1	0	1	1	0	1	1
1	1	1	0	0	1	1	1	0	0
1	1	1	1	1	1	1	1	1	0

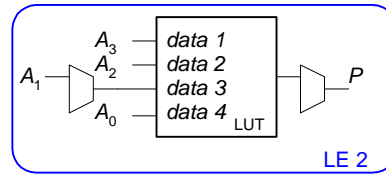
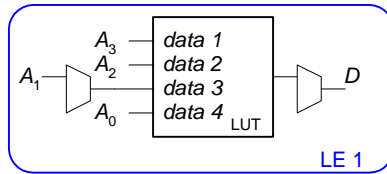

(e) 2 LEs

(A <sub>3</sub> ) data 1	(A <sub>2</sub> ) data 2	(A <sub>1</sub> ) data 3	(A <sub>0</sub> ) data 4	(Y <sub>0</sub> ) LUT output	(A <sub>3</sub> ) data 1	(A <sub>2</sub> ) data 2	(A <sub>1</sub> ) data 3	(A <sub>0</sub> ) data 4	(Y <sub>1</sub> ) LUT output
0	0	0	0	0	0	0	0	0	0
0	0	0	1	0	0	0	0	1	0
0	0	1	0	1	0	0	1	0	0
0	0	1	1	1	0	0	1	1	0
0	1	0	0	0	0	1	0	0	1
0	1	0	1	0	0	1	0	1	1
0	1	1	0	0	0	1	1	0	1
0	1	1	1	0	0	1	1	1	1
1	0	0	0	1	1	0	0	0	1
1	0	0	1	1	1	0	0	1	1
1	0	1	0	1	1	0	1	0	1
1	0	1	1	1	1	0	1	1	1
1	1	0	0	1	1	1	0	0	1
1	1	0	1	1	1	1	0	1	1
1	1	1	0	1	1	1	1	0	1
1	1	1	1	1	1	1	1	1	1

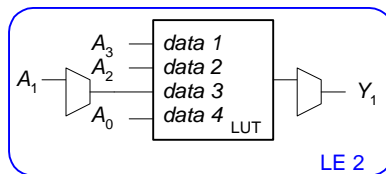
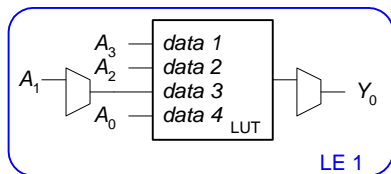

**Exercise 5.61**

(a) 5 LEs (2 for next state logic and state registers, 3 for output logic)

(b)

$$\begin{aligned}
 t_{pd} &= t_{pd\_LE} + t_{wire} \\
 &= (381+246) \text{ ps} \\
 &= 627 \text{ ps}
 \end{aligned}$$

$$\begin{aligned}
 T_c &\geq t_{pcq} + t_{pd} + t_{setup} \\
 &\geq [199 + 627 + 76] \text{ ps} \\
 &= 902 \text{ ps}
 \end{aligned}$$

$$f = 1 / 902 \text{ ps} = \mathbf{1.1 \text{ GHz}}$$

(c)

First, we check that there is no hold time violation with this amount of clock skew.

$$\begin{aligned}
 t_{cd\_LE} &= t_{pd\_LE} = 381 \text{ ps} \\
 t_{cd} &= t_{cd\_LE} + t_{wire} = 627 \text{ ps}
 \end{aligned}$$



$$\begin{aligned}t_{\text{skew}} &< (t_{ccq} + t_{cd}) - t_{\text{hold}} \\ &< [(199 + 627) - 0] \text{ ps} \\ &< \mathbf{826 \text{ ps}}\end{aligned}$$

3 ns is less than 826 ps, so there is no hold time violation.

Now we find the fastest frequency at which it can run.

$$\begin{aligned}T_c &\geq t_{pcq} + t_{pd} + t_{\text{setup}} + t_{\text{skew}} \\ &\geq [0.902 + 3] \text{ ns} \\ &= 3.902 \text{ ns} \\ f &= 1 / 3.902 \text{ ns} = \mathbf{256 \text{ MHz}}\end{aligned}$$

### Exercise 5.63

---

First, we find the cycle time:

$$T_c = 1/f = 1/100 \text{ MHz} = 10 \text{ ns}$$

$$T_c \geq t_{pcq} + Nt_{\text{LE+wire}} + t_{\text{setup}}$$

$$10 \text{ ns} \geq [0.199 + N(0.627) + 0.076] \text{ ns}$$

Thus,  $N \leq 15.5$

The maximum number of LEs on the critical path is **15**.

With at most one LE on the critical path and no clock skew, the fastest the FSM will run is:

$$T_c \geq [0.199 + 0.627 + 0.076] \text{ ns}$$

$$\geq 0.902 \text{ ns}$$

$$f = 1 / 0.902 \text{ ns} = \mathbf{1.1 \text{ GHz}}$$

### Question 5.1

---

$$(2^N - 1)(2^N - 1) = 2^{2N} - 2^{N+1} + 1$$

**Question 5.3**

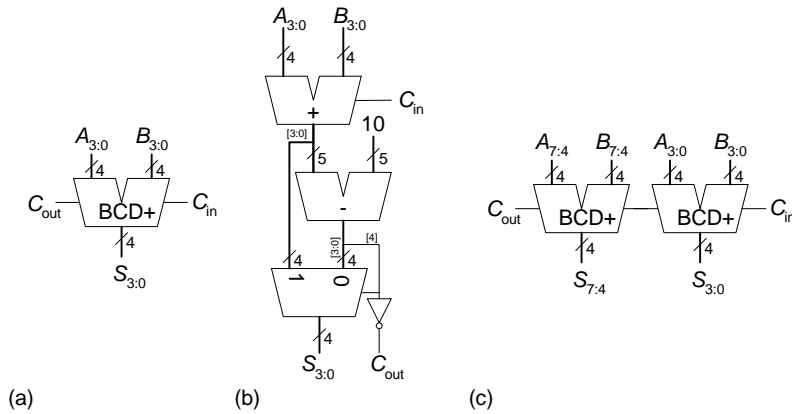

**FIGURE 5.10** BCD adder: (a) 4-bit block, (b) underlying hardware, (c) 8-bit BCD adder

*(continued from previous page)*

## SystemVerilog

```
module bcdadd_8(input logic [7:0] a, b,
               input logic cin,
               output logic [7:0] s,
               output logic cout);

    logic c0;

    bcdadd_4 bcd0(a[3:0], b[3:0], cin, s[3:0], c0);
    bcdadd_4 bcd1(a[7:4], b[7:4], c0, s[7:4], cout);

endmodule

module bcdadd_4(input logic [3:0] a, b,
               input logic cin,
               output logic [3:0] s,
               output logic cout);

    logic [4:0] result, sub10;

    assign result = a + b + cin;
    assign sub10 = result - 10;

    assign cout = ~sub10[4];
    assign s = sub10[4] ? result[3:0] : sub10[3:0];

endmodule
```

## VHDL

```
library IEEE; use IEEE.STD_LOGIC_1164.all;

entity bcdadd_8 is
    port(a, b: in STD_LOGIC_VECTOR(7 downto 0);
          cin: in STD_LOGIC;
          s: out STD_LOGIC_VECTOR(7 downto 0);
          cout: out STD_LOGIC);
end;

architecture synth of bcdadd_8 is
    component bcdadd_4
        port(a, b: in STD_LOGIC_VECTOR(3 downto 0);
              cin: in STD_LOGIC;
              s: out STD_LOGIC_VECTOR(3 downto 0);
              cout: out STD_LOGIC);
    end component;
    signal c0: STD_LOGIC;
begin
    bcd0: bcdadd_4
        port map(a(3 downto 0), b(3 downto 0), cin, s(3
downto 0), c0);
    bcd1: bcdadd_4
        port map(a(7 downto 4), b(7 downto 4), c0, s(7
downto 4), cout);

end;

library IEEE; use IEEE.STD_LOGIC_1164.all;
use IEEE.STD_LOGIC_UNSIGNED.all;
use IEEE.STD_LOGIC_ARITH.all;

entity bcdadd_4 is
    port(a, b: in STD_LOGIC_VECTOR(3 downto 0);
          cin: in STD_LOGIC;
          s: out STD_LOGIC_VECTOR(3 downto 0);
          cout: out STD_LOGIC);
end;

architecture synth of bcdadd_4 is
    signal result, sub10, a5, b5: STD_LOGIC_VECTOR(4
downto 0);
begin
    a5 <= '0' & a;
    b5 <= '0' & b;
    result <= a5 + b5 + cin;
    sub10 <= result - "01010";

    cout <= not (sub10(4));
    s <= result(3 downto 0) when sub10(4) = '1'
        else sub10(3 downto 0);

end;
```

# CHAPTER 6

## Exercise 6.1

---

### (1) Regularity supports simplicity

- Each instruction has a 2-bit opcode.
- Each instruction has a 4-bit condition code.
- ARM has 3 instruction formats for the most common instructions (Data-processing format, Memory format, and Branch format).
- The Data-processing and Memory instruction formats have a similar number and order of operands.
- Each instruction is the same size, making decoding hardware simple.

### (2) Make the common case fast

- Registers make the access to most recently accessed variables fast.
- The RISC (reduced instruction set computer) architecture, makes the common/simple instructions fast because the computer must handle only a small number of simple instructions.
- Most instructions require all 32 bits of an instruction, so all instructions are 32 bits (even though some would have an advantage of a larger instruction size and others a smaller instruction size). The instruction size is chosen to make the common instructions fast.

### (3) Smaller is faster

- The register file has only 16 registers.
- The ISA (instruction set architecture) includes only a small number of commonly used instructions. This keeps the hardware small and, thus, fast.
- The instruction size is kept small to make instruction fetch fast.

### (4) Good design demands good compromises

- ARM uses three instruction formats (instead of just one).
- Ideally all accesses would be as fast as a register access, but ARM architecture also supports main memory accesses to allow for a compromise between fast access time and a large amount of memory.
- Because ARM is a RISC architecture, it includes only a set of simple instructions, but it provides pseudocode to the user and compiler for commonly used operations, like NOP.
- ARM provides three formats to encode immediate values (and four if you count the 5-bit immediate encoding for a shift, `shamt5`):
  - `{rot3:0, imm87:0}` for data-processing instructions
  - `imm1211:0` for memory instructions

- **imm24**<sub>23:0</sub> for branch instructions

**Exercise 6.3**

- (a)  $42 \times 4 = 42 \times 22 = 1010102 \ll 2 = 101010002 = 0xA8$   
 (b) 0xA8 through 0xAB  
 (c)

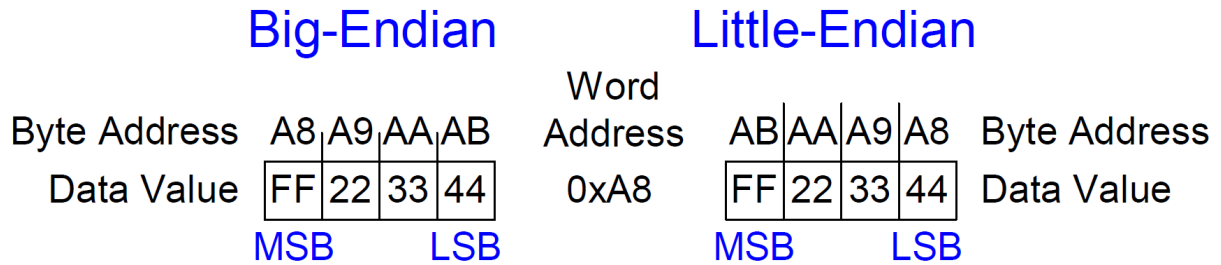

**Exercise 6.5**

In big-endian format, the bytes are numbered from 100 to 103 from left to right. In little-endian format, the bytes are numbered from 100 to 103 from right to left. Thus, the load byte instruction (LDRB) returns a different value depending on the endianness of the machine. At the end of the program R2 contains 0xBC on a big-endian machine and 0xD8 on a little-endian machine.

**Exercise 6.7**

- (a) 0x68 6F 77 64 79 00  
 (b) 0x6C 69 6F 6E 73 00  
 (c) 0x54 6F 20 74 68 65 20 72 65 73 63 75 65 21 00

**Exercise 6.9**

**Little-Endian Memory**

Word Address	Data			
⋮	⋮	⋮	⋮	⋮
10001010			00	79
1000100C	64	77	6F	68
⋮	⋮	⋮	⋮	⋮
⋮	⋮	⋮	⋮	⋮

(a)

Word Address	Data			
⋮	⋮	⋮	⋮	⋮
10001010			00	73
1000100C	6E	6F	69	6C
⋮	⋮	⋮	⋮	⋮
⋮	⋮	⋮	⋮	⋮

(b)

Word Address	Data			
⋮	⋮	⋮	⋮	⋮
10001018		00	21	65
10001014	75	63	73	65
10001010	72	20	65	68
1000100C	74	20	6F	54
⋮	⋮	⋮	⋮	⋮
⋮	⋮	⋮	⋮	⋮

(c)

**Big-Endian Memory**

Word Address	Data			
⋮	⋮	⋮	⋮	⋮
10001010	79	00		
1000100C	68	6F	77	64
⋮	⋮	⋮	⋮	⋮
⋮	⋮	⋮	⋮	⋮

(a)

Word Address	Data			
⋮	⋮	⋮	⋮	⋮
10001010	73	00		
1000100C	6C	69	6F	6E
⋮	⋮	⋮	⋮	⋮
⋮	⋮	⋮	⋮	⋮

(b)

Word Address	Data			
⋮	⋮	⋮	⋮	⋮
10001018	65	21	00	
10001014	65	73	63	75
10001010	68	65	20	72
1000100C	54	6F	20	74
⋮	⋮	⋮	⋮	⋮
⋮	⋮	⋮	⋮	⋮

(c)

**Exercise 6.11**

0xE0808001  
 0xE593B004  
 0xE2475058  
 0xE1A03702

**Exercise 6.13**

- (a) SUB R5, R7, #0x58
- (b) rot = 0, imm8 = 0x58

**Exercise 6.15**

**ARM Assembly**

```

; R0 = decimal number, R1 = base address of array,
; R2 = val, R3 = tmp
MOV R2, #31
L1 LSR R3, R0, R2
AND R3, R3, #1
STRB R3, [R1], #1
SUBS R2, R2, #1
    
```

```

        BPL  L1
L2     MOV  PC, LR

```

**C Code**

```

void convert2bin(int num, char binarray[]){
    int i;
    char tmp, val = 31;

    for (i=0; i<32; i++) {
        tmp = (num >> val) & 1;
        binarray[i] = tmp;
        val--;
    }
}

```

**In words**

This program converts an unsigned integer (R0) from decimal to binary and stores it in an array pointed to by R1.

**Exercise 6.17**

---

```

        AND R0, R1, R2
        MVN R0, R0

```

**Exercise 6.19**

(a)

(i)

```

        CMP R0, R1          ; g > h?
        BLE ELSE
        ADD R0, R0, #1      ; g = g + 1
        B    DONE
ELSE   SUB R0, R1, #1      ; g = h - 1
DONE

```

(ii)

```

        CMP R0, R1          ; g <= h?
        BGT ELSE
        MOV R0, #0          ; g = 0
        B    DONE
ELSE   MOV R1, #0          ; h = 0
DONE

```

(b)

(i)

```

CMP    R0, R1        ; g > h?
ADDGT  R0, R0, #1    ; g = g + 1
SUBLE  R1, R1, #1    ; h = h - 1

```

(ii)

```

CMP    R0, R1        ; g <= h?
MOVLE  R0, #1        ; g = 0
MOVGT  R1, #0        ; h = 0

```

(c) When conditional execution is available for all instructions, it takes 3 instructions, compared to 5 instructions when conditional execution is allowed only for branch instructions. So, in this case, allowing conditional execution for all instructions results in a 40% decrease in the number of instructions.

Thus, the advantages of conditional execution are (1) 40% less memory required for instruction storage, and (2) potentially decreased execution time. The execution time of the code in part (a) is 3-4 instructions, whereas it is 3 instructions in part (b). As will be seen in Chapter 7, the number of instructions fetched in part (a) can be even higher when using a pipelined processor.

A disadvantage of (b) over (a) is that all instructions require a condition code, which uses four bits of encoding that could be used for something else. However, as shown, this cost in bits used for encoding the condition is usually well worth it.

### Exercise 6.21

---

(a)

```

ADD R2, R3, #0x190 ; R2 = end of array
FOR  CMP R3, R2    ; reached end of array?
    BGE DONE
    LDR R1, [R3]   ; R1 = array[i]
    LSL R1, R1, #5 ; R1 = array[i] * 32
    STR R1, [R3]   ; array[i] = array[i] * 32
    ADD R3, R3, #4 ; R3 points to next array entry
    B   FOR
DONE

```

(b)

```

ADD R2, R3, #0x190 ; R2 = end of array

```



```

FOR  CMP R3, R2           ; reached end of array?
     BGE DONE
     LDR R1, [R3]         ; R1 = array[i]
     LSL R1, R1, #7       ; R1 = array[i] * 128
     STR R1, [R3], #4     ; array[i] = array[i] * 128
                               ; R3 points to next array entry
     B   FOR
DONE

```

(c) part (a) has 8 instructions and part (b) has 7 instructions. The loop code particularly decreases from 7 instructions to 6 instructions. This is a 12.5% decrease in the number of instructions and a 14% decrease in loop instructions. The advantages are: (1) 12.5% lower memory requirements for code storage, and (2) decreased execution time (approximately 14% decrease because most of the execution time is spent in the loop). The disadvantage is the number of bits required for encoding the indexing mode.

### Exercise 6.23

---

(a) Yes.

(b)

(i)

```

     MOV R1, #0           ; i = 0
FOR  CMP R1, #10         ; reached end of array?
     BGE DONE
     LDR R2, [R0, R1, LSL #2] ; R2 = nums[i]
     LSR R2, R2, #1       ; R2 = nums[i]/2
     STR R2, [R0, R1, LSL #2] ; nums[i] = nums[i]/2
     ADD R1, R1, #1      ; i = i + 1
     B   FOR
DONE

```

(ii)

```

     MOV R1, #9          ; i = 9
FOR  LDR R2, [R0, R1, LSL #2] ; R2 = nums[i]
     LSR R2, R2, #1       ; R2 = nums[i]/2
     STR R2, [R0, R1, LSL #2] ; nums[i] = nums[i]/2
     SUBS R1, R1, #1      ; i = i - 1 and set flags
     BPL FOR

```

(c) The second code snippet (ii), the decremented loop, uses fewer instructions and is faster. Each loop iteration in code snippet (ii) requires 5 instead of the 7 instructions required for code

snippet (i). Code snippet ii combines checking the loop condition with updating the loop variable, i.

**Exercise 6.25**

---

```
(a)
; ARM assembly code
; base address of array dst = R0
; base address of array src = R1
; i = R4

STRCPY
    PUSH {R4}           ; save R4 on stack
    MOV R4, #0          ; i = 0
LOOP
    LDRB R2, [R1, R4]   ; R2 = src[i]
    STRB R2, [R0, R4]   ; dst[i] = src[i]
    CMP R2, #0          ; array[i] == 0? (end of string?)
    ADD R4, R4, #1      ; i++
    BNE LOOP           ; if not, repeat
DONE
    POP {R4}           ; restore R4
    MOV PC, LR         ; return
```

(b) The stack (i) before, (ii) during, and (iii) after the strcpy procedure.

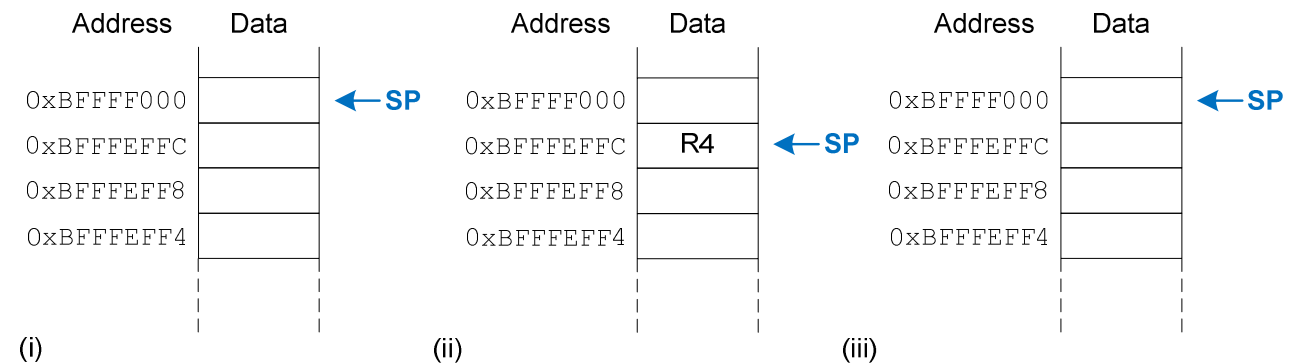

**Exercise 6.27**

---

- (a)
  - func1: 8 words (for R4-R10 and LR)
  - func2: 3 words (for R4-R5 and LR)
  - func3: 4 words (for R7-R9 and LR)
  - func4: 1 word (for R11)

(b)

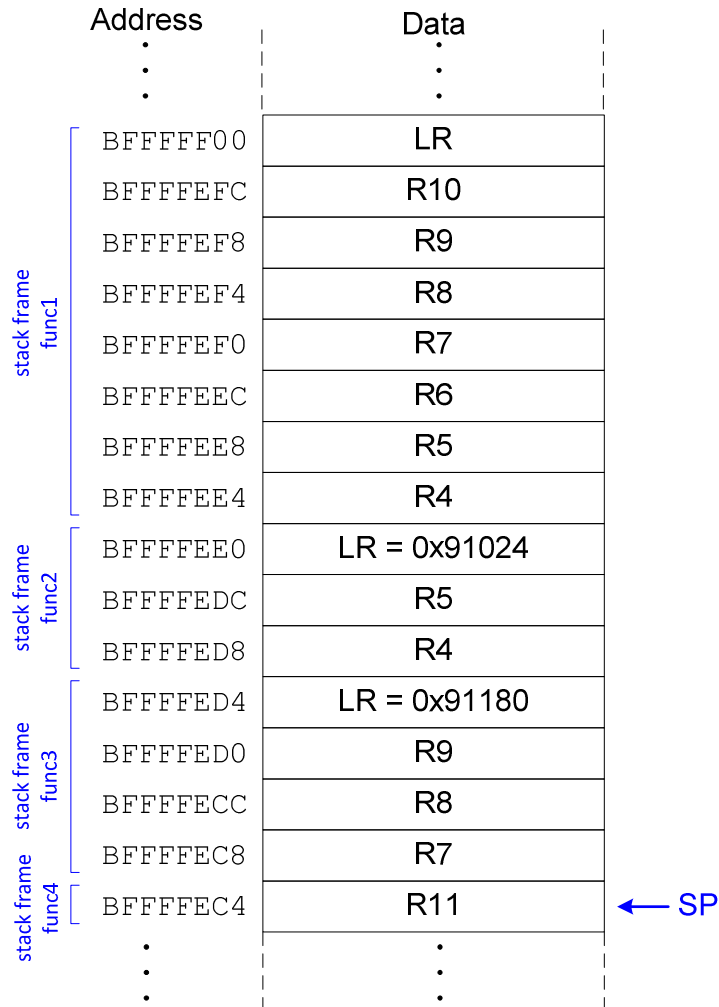

**Exercise 6.29**

- 
- (a) 120
  - (b) (2)
  - (c) (i) (3) returned value is R1<sup>4</sup>
  - (ii) (3) returned value is R1<sup>4</sup>
  - (iii) (4)

**Exercise 6.31**

- 
- (a) 0xa0000001
  - (b) 0xaa00000e
  - (c) 0x8aff841
  - (d) 0xeb00391d
  - (e) 0xeaffe3fc

**Exercise 6.33**

(a)

```

; R4 = i, R5 = num
SETARRAY
    PUSH {R4, R5, LR}          ; save R4, R5, and LR on the stack
    SUB SP, SP, #40           ; allocate space on stack for array
    MOV R4, #0                ; i = 0
    MOV R5, R0                ; R5 = num

LOOP MOV R1, R4                ; set up input arguments
    BL COMPARE                ; call compare function
    STR R0, [SP, R4, LSL #2]  ; array[i] = return value
    ADD R4, R4, #1            ; increment i
    MOV R0, R5                ; arg0 = num
    CMP R4, #10               ; i < 10?
    BLT LOOP

    ADD SP, SP, #40           ; deallocate space on stack for array
    POP {R4, R5, LR}         ; restore registers
    MOV PC, LR                ; return to point of call

COMPARE
    PUSH {LR}                ; save LR
    BL SUBFUNC                ; call sub function
    CMP R0, #0                ; returned value >= 0?
    MOVGE R0, #1              ; if yes, R0 = 1
    MOVLTI R0, #0             ; if no, R0 = 0
    POP {LR}                  ; restore LR
    MOV PC, LR                ; return to point of call

SUBFUNC
    SUB R0, R0, R1            ; return a-b
    MOV PC, LR                ; return to point of call

```

(b)

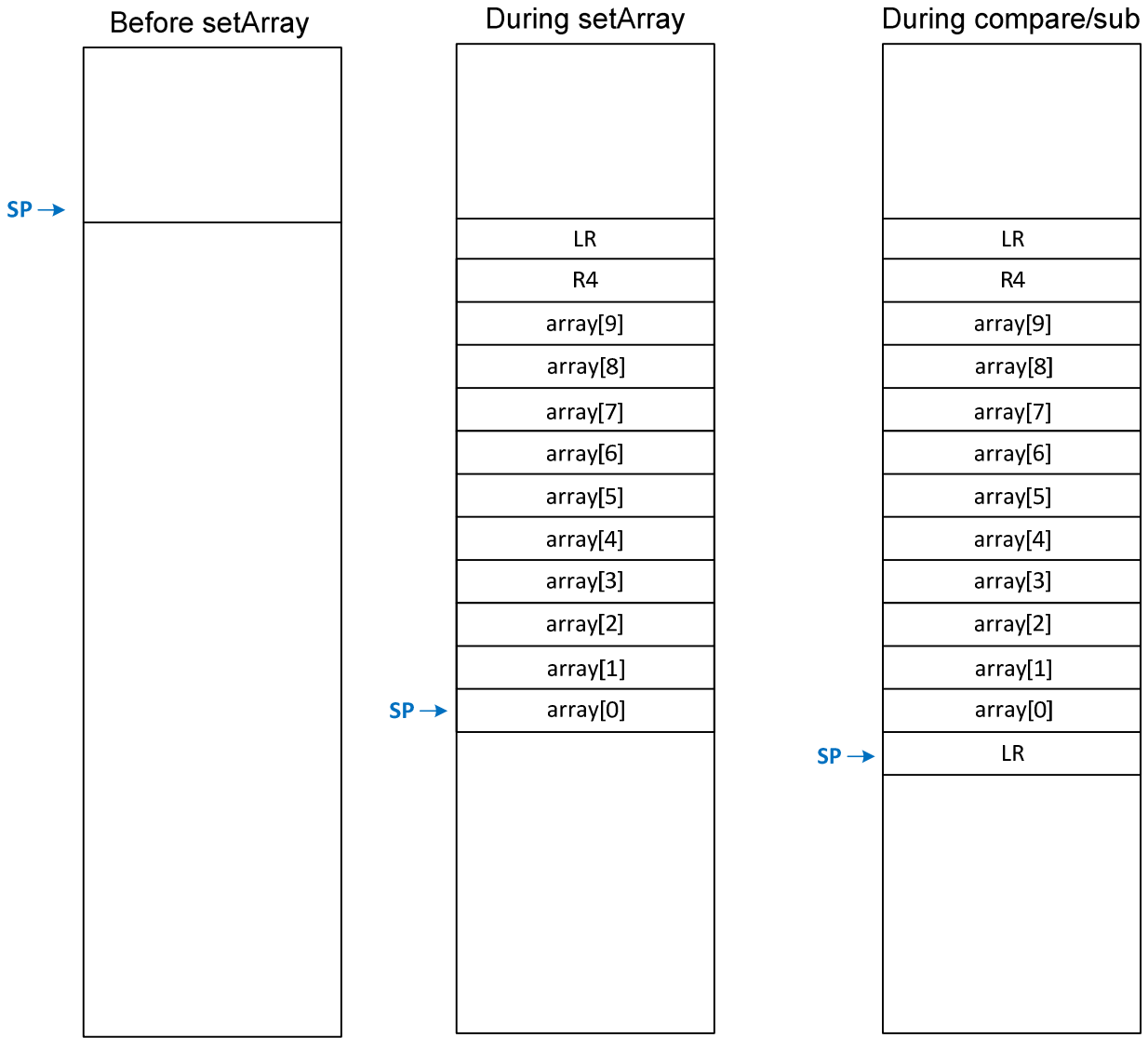

(c) The code would enter an infinite loop and eventually crash. When the `compare` function returns (`MOV PC, LR`), instead of returning to its point of call in the `setArray` function, the `compare` function would continue executing at the instruction just after the call to `sub` (`BL SUBFUNC`). Because of the `POP {LR}` instruction, the program would eventually crash when it went beyond the stack space available (i.e., the stack pointer was decremented past the allocated dynamic data segment).

**Exercise 6.35**

---

The largest address offset (imm24) a branch instruction (B or BL) can encode is  $2^{24}-1 = 16,777,215$ . Since the offset adds to the address 2 instructions ahead of the current instruction (i.e., at PC + 8), a branch can branch forward at most  $(2^{24}-1) + 2 = 16,777,217$  instructions. Because instructions are relative to PC + 4, it can branch forward between 0 and **16,777,217** instructions relative to the current instruction. So, if the current instruction address is **0x0**. The farthest it can branch forward is to instruction address  $16,777,217 * 4 = 67,108,868 =$  **0x4000004**.

**Exercise 6.37**

---

It is advantageous to have a large address field in the machine format for branch instructions to increase the range of instruction addresses to which the instruction can branch.

**Exercise 6.39**

---

```
// High-Level Code
void little2big(int[] array) {
    int i;

    for (i = 0; i < 10; i = i + 1) {
        array[i] = ((array[i] << 24) |
                    ((array[i] & 0xFF00) << 8) |
                    ((array[i] & 0xFF0000) >> 8) |
                    ((array[i] >> 24) & 0xFF));
    }
}

; ARM Assembly Code
; R0 = base address of array, R12 = i
little2BIG
    MOV    R12, #0                ; i = 0
LOOP
    CMP    R12, #10              ; i < 10?
    BGE    DONE
    LDR    R2, [R0, R12, LSL #2] ; R2 = array[i]
    LSL    R3, R2, #24           ; R3 = array[i] << 24
    AND    R4, R2, #0xFF00      ; R4 = (array[i] & 0xFF00)
    ORR    R3, R3, R4, LSL #8   ; R3 = top two bytes
    AND    R4, R2, #0xFF0000    ; R4 = (array[i] & 0xFF0000)
    ORR    R3, R3, R4, LSR #8   ; R3 = top three bytes
    ORR    R3, R3, R2, LSR #24  ; R3 = all four bytes
    STR    R3, [R0, R12, LSL #2] ; array[i] = R3
    ADD    R12, R12, #1         ; increment i
    B     LOOP
DONE
    MOV    PC, LR
```

**Exercise 6.41**

---

```

; R4, R5 = mantissas of a, b, R6, R7 = exponents of a, b

FLPADD
    PUSH {R4, R5, R6, R7, R8} ; save registers that will be used
    LDR R2, =0x007fffff ; load mantissa mask
    LDR R3, =0x7f800000 ; load exponent mask
    AND R4, R0, R2 ; extract mantissa from R0 (a)
    AND R5, R1, R2 ; extract mantissa from R1 (b)
    ORR R4, R4, #0x800000 ; insert implicit leading 1
    ORR R5, R5, #0x800000 ; insert implicit leading 1
    AND R6, R0, R3 ; extract exponent from R0 (a)
    LSR R6, R6, #23 ; shift exponent right
    AND R7, R1, R3 ; extract exponent from R1 (b)
    LSR R7, R7, #23 ; shift exponent right

MATCH
    CMP R6, R7 ; compare exponents
    BEQ ADDMANTISSA ; if equal, skip to adding mantissas
    BHI SHIFTB ; if a's exponent is bigger, shift b

SHIFTA
    SUB R8, R7, R6 ; R8 = b's exponent - a's exponent
    ASR R4, R4, R8 ; right-shift a's mantissa
    ADD R6, R6, R8 ; update a's exponent
    B ADDMANTISSA ; now add the mantissas

SHIFTB
    SUB R8, R6, R7 ; R8 = a's exponent - b's exponent
    ASR R5, R5, R8 ; right-shift b's mantissa

ADDMANTISSA
    ADD R4, R4, R5 ; R4 = sum of mantissas

NORMALIZE
    ANDS R5, R4, #0x1000000 ; extract overflow bit
    BEQ DONE ; branch to DONE if bit 24 == 0
    LSR R4, R4, #1 ; right-shift mantissa by 1 bit
    ADD R6, R6, #1 ; increment exponent

DONE
    AND R4, R4, R2 ; mask fraction
    LSL R6, R6, #23 ; shift exponent into place
    ORR R0, R4, R6 ; combine mantissa and exponent
    POP {R4, R5, R6, R7, R8} ; restore registers
    MOV PC, LR ; return to caller

```

**Exercise 6.43**

(a)

```

; ARM assembly code
0x8534      MAIN      PUSH {R4,LR}
0x8538      MOV R4, #15
0x853c      LDR R3, =L2
0x8540      STR R4, [R3]
0x8544      MOV R1, #27
0x8548      STR R1, [R3, #4]
0x854c      LDR R0, [R3]
0x8550      BL GREATER
0x8554      POP {R4,LR}
0x8558      MOV PC, LR
0x855c      GREATER  CMP R0, R1
0x8560      MOV R0, #0
0x8564      MOVGT R0, #1
0x8568      MOV PC, LR
...
0x9305      L2
    
```

(b)

**Symbol Table**

Address	Label
0x8534	MAIN
0x8550	GREATER
0x9305	L2

(c)

```

; machine code      ;address      ARM assembly
E92D4010           ;0x8534      MAIN      PUSH {R4,LR}
                  ;                               STMDB R13!, {R4,R14}
E3A0400F           ;0x8538      MOV R4, #15
E59F3DC1           ;0x853c      LDR R3, =L2
E5834000           ;0x8540      STR R4, [R3]
E3A0101B           ;0x8544      MOV R1, #27
E5831004           ;0x8548      STR R1, [R3, #4]
E5930000           ;0x854c      LDR R0, [R3]
EB000001           ;0x8550      BL GREATER
E8BD4010           ;0x8554      POP {R4,LR}
                  ;                               LDMIA R13!, {R4,R14}
E1A0F00E           ;0x8558      MOV PC, LR
E1500001           ;0x855c      GREATER  CMP R0, R1
E3A00000           ;0x8560      MOV R0, #0
C3A00001           ;0x8564      MOVGT R0, #1
E1A0F00E           ;0x8568      MOV PC, LR
...
    
```



```
        ;0x9305    L2
```

(d)

**Text Segment:** 15\*4 = 60 bytes**Data segment:** 4 bytes**Exercise 6.45**

Advantages of conditional execution:

- Potentially decreased code size (increased code density)
- Potentially decreased execution time (improved performance)

Disadvantages:

- More complex hardware required to implement it
- Requires 4 instruction bits to encode

**Question 6.1**

```
EOR R0, R0, R1    ; R0 = R0 XOR R1
EOR R1, R0, R1    ; R1 = original value of R0
EOR R0, R0, R1    ; R0 = original value of R1
```

**Question 6.3****C Code**

```
void reversewords(char[] array) {
    int i, j, length;

    // find length of string
    for (i = 0; array[i] != 0; i = i + 1)
        ;

    length = i;

    // reverse characters in string
    reverse(array, length-1, 0);

    // reverse words in string
    i = 0; j = 0;
    // check for spaces or end of string
    while (i <= length) {
        if ( (i != length) && (array[i] != 0x20) ) {
            i = i + 1;
        }
        else {
```

```

        reverse(array, i-1, j);
        i = i + 1; // j and i at start of next word
        j = i;
    }
}
}

```

```

void reverse(char[] array, int i, int j) {
    char tmp;

    while (i > j) {
        tmp = array[i];
        array[i] = array[j];
        array[j] = tmp;
        i = i-1;
        j = j+1;
    }
}

```

### ARM Assembly

```

; R4 = i, R5 = j, R6 = length
REVERSEWORDS
    PUSH {R4,R5,R6}      ; save registers on stack
    MOV R4, #0           ; i = 0
GETLENGTH
    LDRB R1, [R0, R4]    ; R1 = array[i]
    CMP R1, #0           ; end of string?
    ADDNE R4, R4, #1     ; i = i + 1
    BNE GETLENGTH
STRINGREVERSE
    MOV R6, R4           ; length = i
    SUB R1, R6, #1      ; arg1 = length-1
    MOV R2, #0          ; arg2 = 0
    BL REVERSE          ; call reverse function
    MOV R4, #0          ; i = 0
    MOV R5, #0          ; j = 0
WHILE19
    CMP R4, R6          ; i <= length?
    BGT DONE19         ; if at end of string, return
    BEQ ELSE19         ; if (i == length), do else block
    LDRB R1, [R0, R4]   ; R1 = array[i]
    CMP R1, #0x20       ; array[i] != 0x20?
    BEQ ELSE19         ; if (array[i] == 0x20), do else block
    ADD R4, R4, #1     ; i = i + 1
    B WHILE19          ; repeat while loop
ELSE19
    SUB R1, R4, #1      ; arg1 = i-1
    MOV R2, R5         ; arg2 = j
    BL REVERSE         ; call reverse function
    ADD R4, R4, #1     ; i = i+1

```

```

        MOV    R5, R4            ; j = i
        B     WHILE19          ; repeat while loop
DONE19
        POP    {R4,R5,R6}      ; restore registers from stack
        MOV    PC, LR          ; retnr to calling function

REVERSE
        CMP    R1, R2          ; i > j?
        BLE   RETURN19
        LDRB   R3, [R0, R1]    ; R3 = array[i]
        LDRB   R12, [R0, R2]   ; R12 = array[j]
        STRB   R12, [R0, R1]   ; array[i] = array[j]
        STRB   R3, [R0, R2]    ; array[j] = tmp
        SUB    R1, R1, #1      ; i = i - 1
        ADD    R2, R2, #1      ; j = j + 1
        B     REVERSE          ; continue while loop
RETURN19
        MOV    PC, LR

```

### Question 6.5

#### C Code

```

num = swap(num, 1, 0x55555555); // swap bits
num = swap(num, 2, 0x33333333); // swap pairs
num = swap(num, 4, 0x0F0F0F0F); // swap nibbles
num = swap(num, 8, 0x00FF00FF); // swap bytes
num = swap(num, 16, 0xFFFFFFFF); // swap halves

// swap function swaps masked bits
int swap(int num, int shamt, unsigned int mask) {
    return ((num >> shamt) & mask) | ((num & mask) << shamt);
}

```

#### ARM Assembly Code

```

        MOV    R0, R3            ; arg0 = num
        MOV    R1, #1           ; arg1 = 1
        LDR    R2, =0x55555555 ; arg2 = 0x55555555
        BL    SWAP              ; call swap function

        MOV    R1, #2           ; arg1 = 1
        LDR    R2, =0x33333333 ; arg2 = 0x33333333
        BL    SWAP              ; call swap function

        MOV    R1, #4           ; arg1 = 1
        LDR    R2, =0x0F0F0F0F ; arg2 = 0x0F0F0F0F
        BL    SWAP              ; call swap function

        MOV    R1, #8           ; arg1 = 1
        LDR    R2, =0x00FF00FF ; arg2 = 0x00FF00FF
        BL    SWAP              ; call swap function

```

```

MOV R1, #16                ; arg1 = 1
LDR R2, =0xFFFFFFFF      ; arg2 = 0xFFFFFFFF
BL SWAP                    ; call swap function
MOV R3, R0                 ; num = returned value
...

SWAP
LSR R3, R0, R1             ; R3 = num >> shamt
AND R3, R3, R2             ; R3 = (num >> shamt) & mask
AND R0, R0, R2             ; R0 = num & mask
LSL R0, R0, R1             ; R0 = (num & mask) << shamt
ORR R0, R3, R0             ; return val = R3 | R0
MOV PC, LR                 ; return to caller

```

**Question 6.7****C Code**

```

bool palindrome(char* array) {
    int i, j; // array indices

    // find length of string
    for (j = 0; array[j] != 0; j=j+1) ;
    j = j-1; // j is index of last char

    i = 0;
    while (j > i) {
        if (array[i] != array[j])
            return false;
        j = j-1;
        i = i+1;
    }
    return true;
}

```

**MIPS Assembly Code**

```

; R1 = i, R2 = j, R0 = base address of string
PALINDROME
    PUSH    {R4}           ; save R4 on stack
    MOV     R2, #0         ; j = 0
GETLENGTH
    LDRB   R3, [R0, R2]   ; R3 = array[j]
    CMP    R3, #0         ; end of string?
    ADDNE  R2, R2, #1     ; j = j + 1
    BNE    GETLENGTH
    SUB    R2, R2, #1     ; j = j - 1
    MOV    R1, #0         ; i = 0
WHILE
    CMP    R2, R1         ; j > i?
    BLE    RETURNTRUE
    LDRB   R3, [R0, R1]   ; R3 = array[i]

```

```
LDRB R4, [R0, R2] ; R4 = array[j]
CMP R3, R4 ; array[i] == array[j]?
BNE RETURNFALSE
SUB R2, R2, #1 ; j = j-1
ADD R1, R1, #1 ; i = i+1
B WHILE
RETURNTRUE
MOV R0, #1 ; return TRUE
B DONE
RETURNFALSE
MOV R0, #0 ; return FALSE
DONE
POP {R4} ; restore R4
MOV PC, LR ; return to caller
```

# CHAPTER 7

## Exercise 7.1

---

- (a) ADD, SUB, AND, ORR, LDR: the result never gets written to the register file.
- (b) SUB, AND, ORR: the ALU only performs addition
- (c) STR: the data memory never gets written

## Exercise 7.3

---

- (a) TST

### ALU Decoder truth table

<i>ALUOp</i>	<i>Funct</i> <sub>4:1</sub> ( <i>cmd</i> )	<i>Funct</i> <sub>0</sub> ( <i>S</i> )	Notes	<i>ALUControl</i> <sub>1:0</sub>	<i>FlagW</i> <sub>1:0</sub>	<i>NoWrite</i>
0	X	X	Not DP	00	00	0
1	0100	0	ADD	00	00	0
		1			11	0
	0010	0	SUB	01	00	0
		1			11	0
	0000	0	AND	10	00	0
		1			10	0
	1100	0	ORR	11	00	0
		1			10	0
1000	1	TST	10	10	1	

### Control Unit Schematic

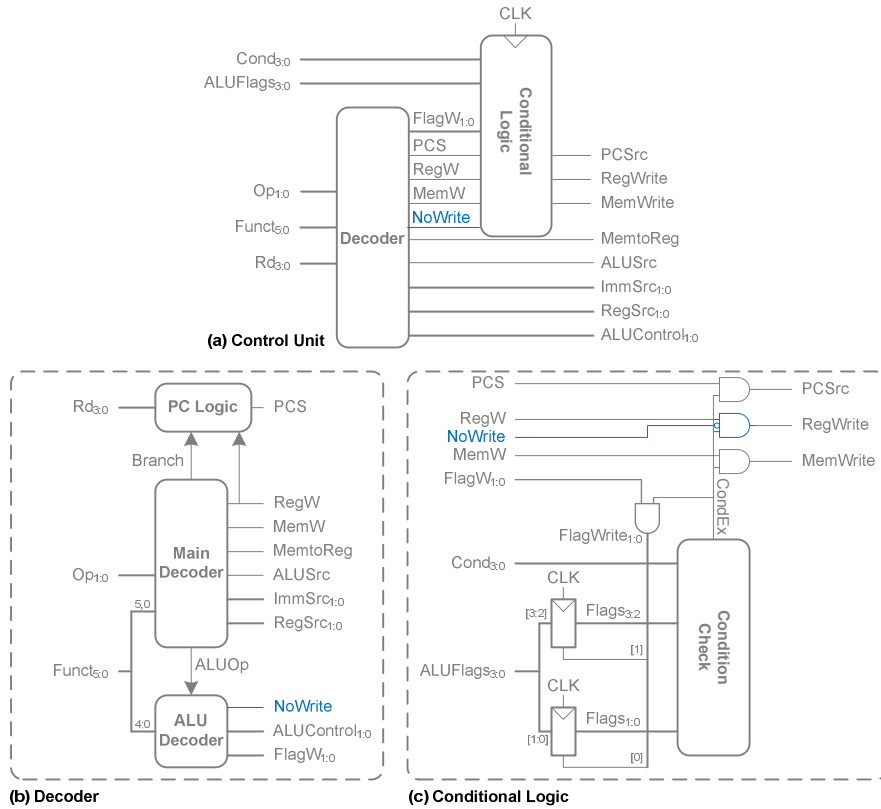

(b) LSL

Single-cycle datapath

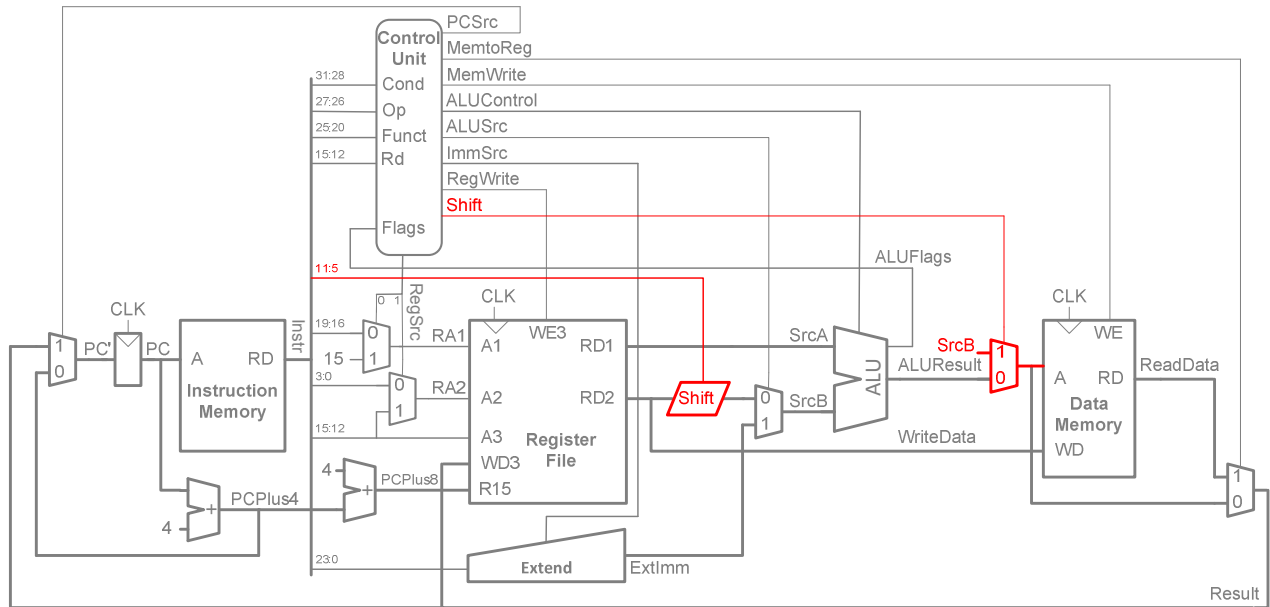

**Control unit**

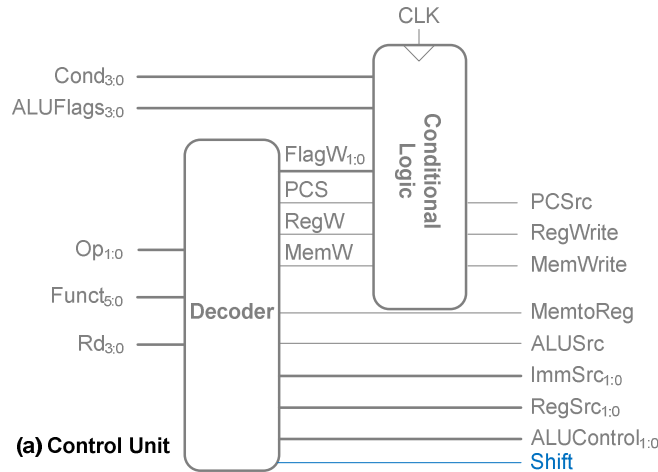

**(a) Control Unit**

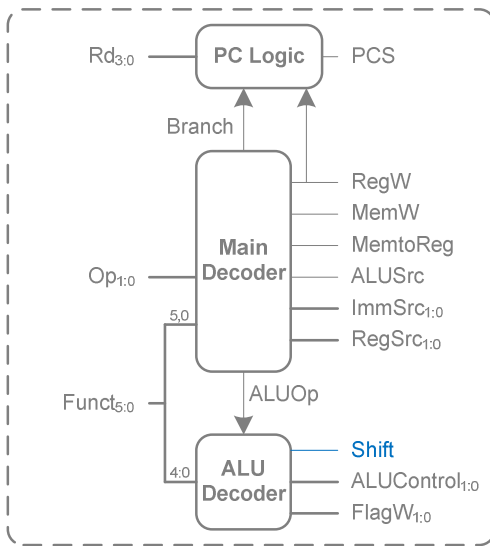

**(b) Decoder**

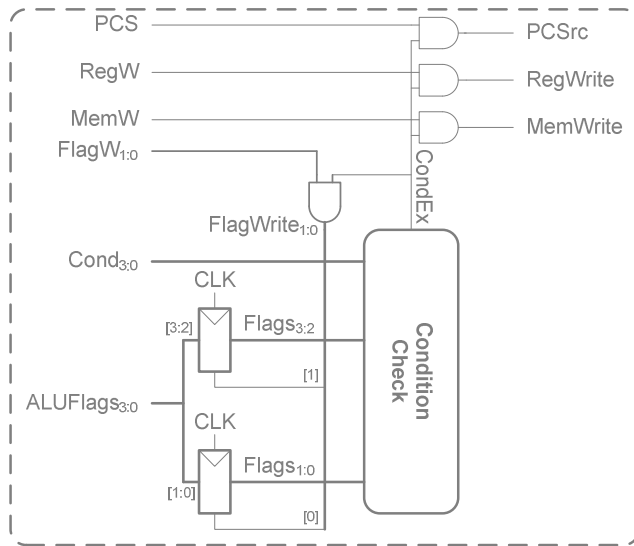

**(c) Conditional Logic**

**ALU Decoder truth table**

<i>ALUOp</i>	<i>Funct</i> <sub>4:1</sub> ( <i>cmd</i> )	<i>Funct</i> <sub>0</sub> ( <i>S</i> )	Notes	<i>ALUControl</i> <sub>1:0</sub>	<i>FlagW</i> <sub>1:0</sub>	<i>Shift</i>
0	X	X	Not DP	00	00	0
1	0100	0	ADD	00	00	0
		1			11	0
	0010	0	SUB	01	00	0
		1			11	0
	0000	0	AND	10	00	0
		1			10	0
	1100	0	ORR	11	00	0
		1			10	0
1101	0	LSL	XX	00	1	
	1			10	1	



(c) CMN

**ALU Decoder truth table**

<i>ALUOp</i>	<i>Funct<sub>4:1</sub> (cmd)</i>	<i>Funct<sub>0</sub> (S)</i>	Notes	<i>ALUControl<sub>1:0</sub></i>	<i>FlagW<sub>1:0</sub></i>	<i>NoWrite</i>
0	X	X	Not DP	00	00	0
1	0100	0	ADD	00	00	0
		1			11	0
	0010	0	SUB	01	00	0
		1			11	0
	0000	0	AND	10	00	0
		1			10	0
	1100	0	ORR	11	00	0
		1			10	0
1011	1	CMN	00	11	1	

**Control Unit schematic**

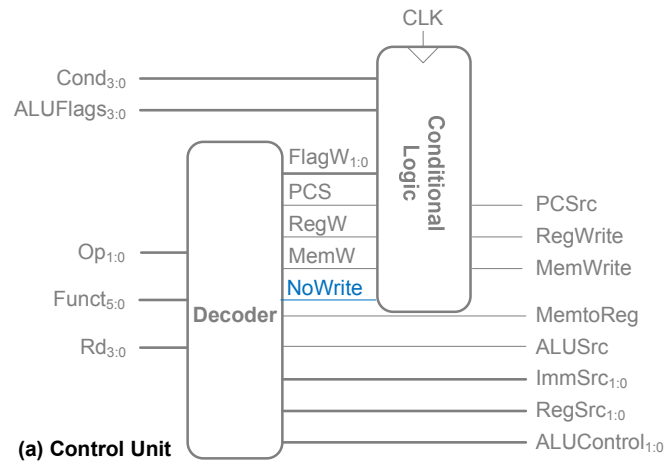

(a) Control Unit

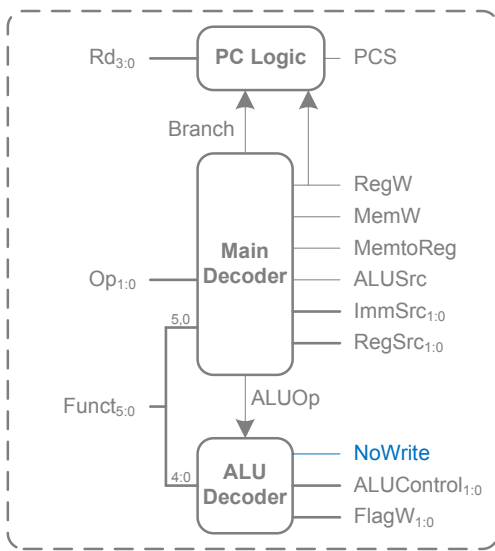

(b) Decoder

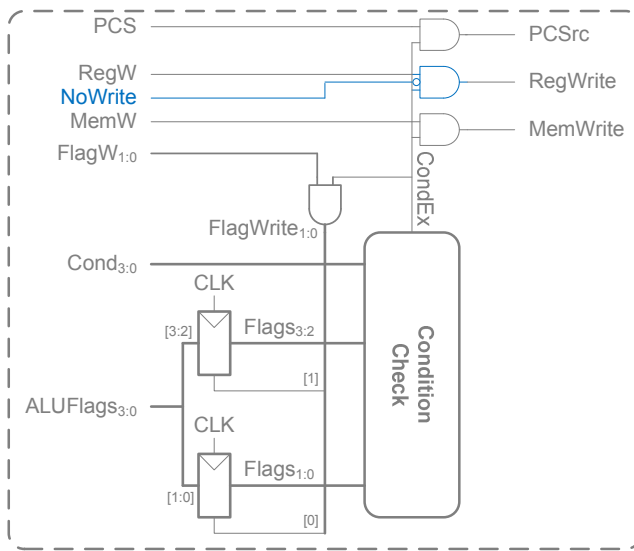

(c) Conditional Logic

(d) ADC

**ALU Decoder truth table**

<i>ALUOp</i>	<i>Funct</i> <sub>4:1</sub> ( <i>cmd</i> )	<i>Funct</i> <sub>0</sub> ( <i>S</i> )	Notes	<i>ALUControl</i> <sub>2:0</sub>	<i>FlagW</i> <sub>1:0</sub>
0	X	X	Not DP	000	00
1	0100	0	ADD	000	00
		1			11
	0010	0	SUB	001	00
		1			11
	0000	0	AND	010	00
		1			10
1100	0	ORR	011	00	
	1			10	

0101	0	ADC	100	00
	1			11

### Single-cycle ARM processor ALU

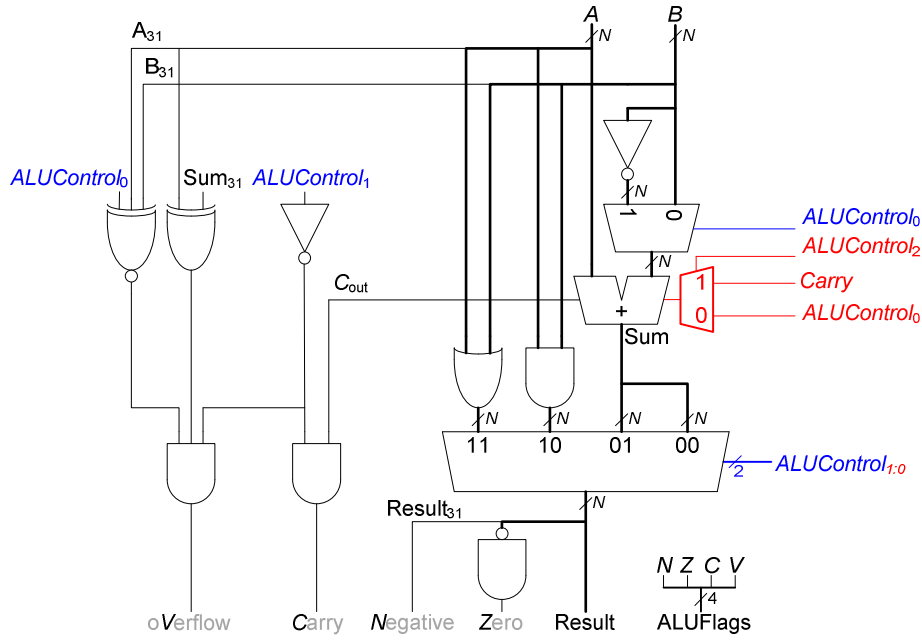

### Single-cycle ARM processor datapath

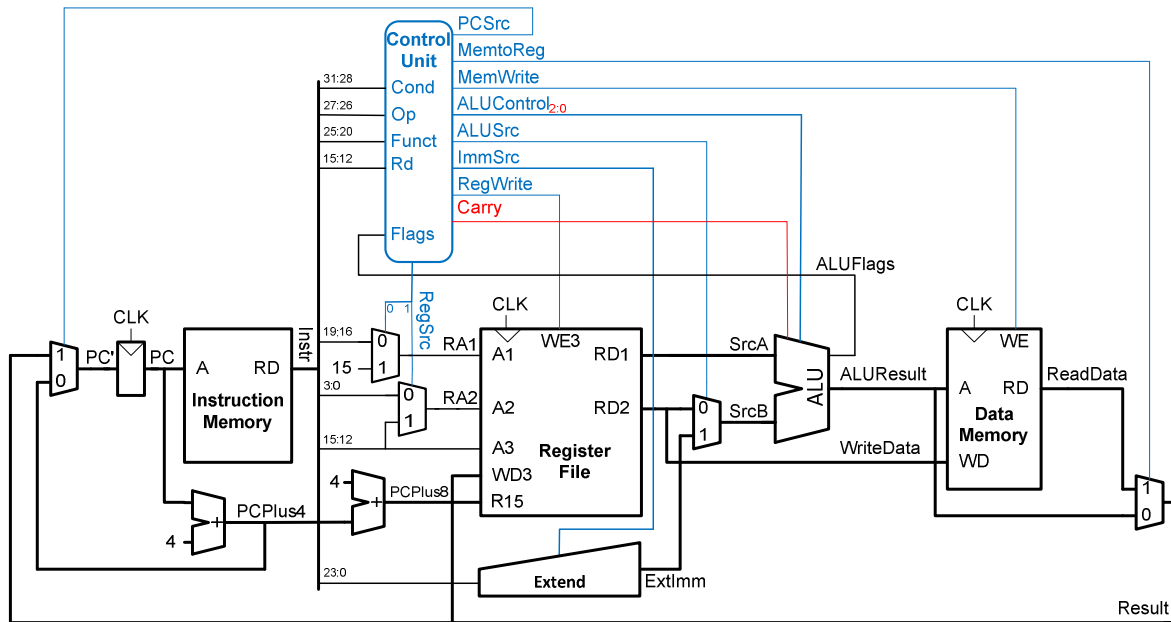

### Single-cycle ARM processor control unit

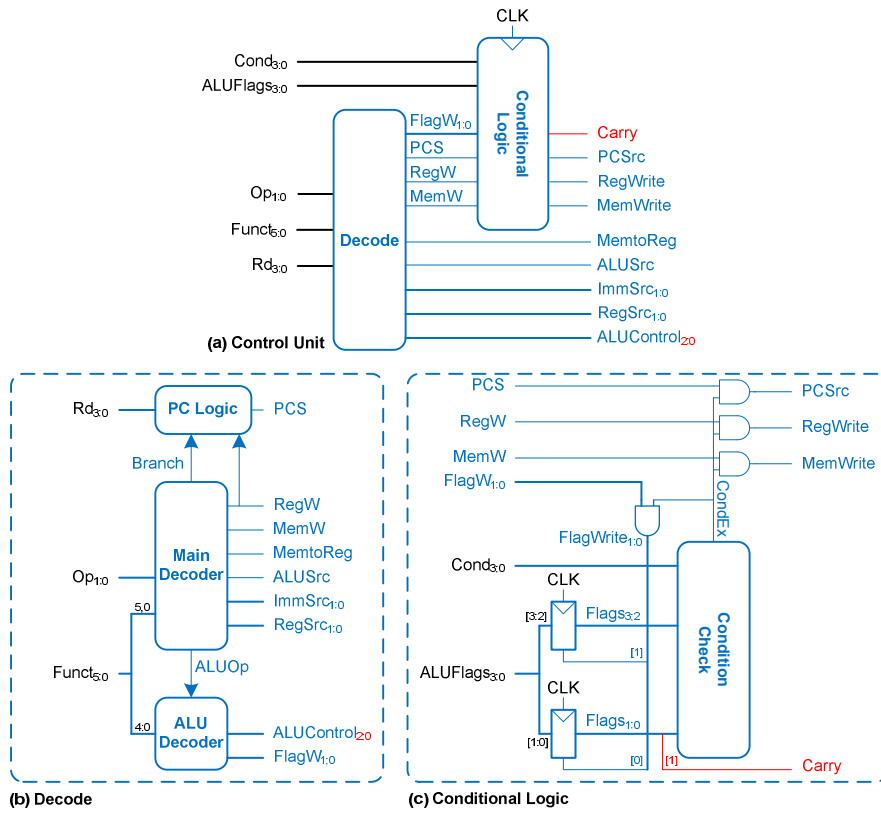

### Exercise 7.5

It is not possible to implement this instruction without either modifying the register file or making the instruction take at least two cycles to execute. We modify the register file and datapath as shown below.

- Add WE1 and WD1 signals to the register file.
- WE1 connects to the PostIndex signal (from control unit)
- WD1 connects to ALUResult, which is the sum of  $R_n + R_m$  (or  $R_n + Src2$ , more generally).
- Add multiplexer before Data Memory Address to choose between  $(R_n + Src2)$  and  $R_n$ .  
With post-indexing, the Data Memory Address input connects to  $R_n$ .

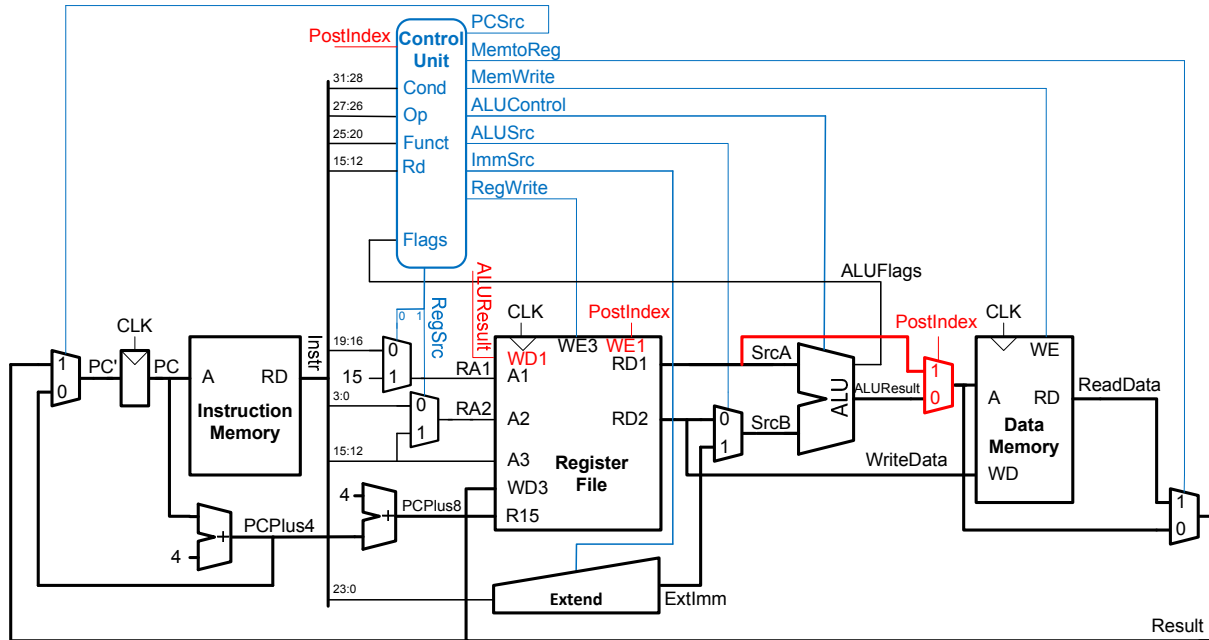

We modified the Main Decoder truth table as shown below.

Op	Func <sub>5:0</sub>	Type	Branch	MemtoReg	MemW	ALUSrc	ImmSrc	RegW	RegSrc	ALUOp	PostIndex
00	0XXXXX	DP Reg	0	0	0	0	XX	1	00	1	0
00	1XXXXX	DP Imm	0	0	0	1	00	1	X0	1	0
01	X00000	STR	0	X	1	1	01	0	10	0	0
01	011001	LDR (offset indexing, immediate offset)	0	1	0	1	01	1	X0	0	0
01	111001	LDR (offset indexing, register offset)	0	1	0	0	01	1	00	0	0
01	001001	LDR (post-indexing, immediate offset)	0	1	0	1	01	1	X0	0	1
01	101001	LDR	0	1	0	0	01	1	00	0	1

		(post-indexing, register offset)										
--	--	----------------------------------	--	--	--	--	--	--	--	--	--	--

**Exercise 7.7**

---

She should work on the memory.  $t_{mem} = (200/2) \text{ ps} = 100 \text{ ps}$

From Equation 7.3, the new cycle time is:

$$T_{c1} = 40 + 2(100) + 70 + 100 + 120 + 2(25) + 60 = \mathbf{640 \text{ ps}}$$

**Exercise 7.9**

---

**SystemVerilog**

```
// ex7.9 solutions
//
// single-cycle ARM processor
// additional instructions: TST, LSL, CMN, ADC

module testbench();

    logic        clk;
    logic        reset;

    logic [31:0] WriteData, DataAdr;
    logic        MemWrite;

    // instantiate device to be tested
    top dut(clk, reset, WriteData, DataAdr, MemWrite);

    // initialize test
    initial
    begin
        reset <= 1; # 22; reset <= 0;
    end

    // generate clock to sequence tests
    always
    begin
        clk <= 1; # 5; clk <= 0; # 5;
    end

    // check results
    always @(negedge clk)
    begin
        if(MemWrite) begin
            if(DataAdr === 20 & WriteData === 2) begin
                $display("Simulation succeeded");
                $stop;
            end
        end
    end
endmodule
```

```

        end else begin
            $display("Simulation failed");
            $stop;
        end
    end
end
endmodule

module top(input  logic          clk, reset,
           output logic [31:0] WriteData, DataAdr,
           output logic          MemWrite);

    logic [31:0] PC, Instr, ReadData;

    // instantiate processor and memories
    arm arm(clk, reset, PC, Instr, MemWrite, DataAdr,
            WriteData, ReadData);
    imem imem(PC, Instr);
    dmem dmem(clk, MemWrite, DataAdr, WriteData, ReadData);
endmodule

module dmem(input  logic          clk, we,
            input  logic [31:0] a, wd,
            output logic [31:0] rd);

    logic [31:0] RAM[63:0];

    assign rd = RAM[a[31:2]]; // word aligned

    always_ff @(posedge clk)
        if (we) RAM[a[31:2]] <= wd;
endmodule

module imem(input  logic [31:0] a,
            output logic [31:0] rd);

    logic [31:0] RAM[63:0];

    initial
        $readmemh("ex7.9_memfile.dat",RAM);

    assign rd = RAM[a[31:2]]; // word aligned
endmodule

module arm(input  logic          clk, reset,
           output logic [31:0] PC,
           input  logic [31:0] Instr,
           output logic          MemWrite,
           output logic [31:0] ALUResult, WriteData,
           input  logic [31:0] ReadData);

    logic [3:0] ALUFlags;
    logic          RegWrite,
                 ALUSrc, MemtoReg, PCSrc;

```

```

logic [1:0] RegSrc, ImmSrc;
logic [2:0] ALUControl; // ADC
logic      carry; // ADC
logic      Shift; // LSL

controller c(clk, reset, Instr[31:12], ALUFlags,
             RegSrc, RegWrite, ImmSrc,
             ALUSrc, ALUControl,
             MemWrite, MemtoReg, PCSrc,
             carry, // ADC
             Shift); // LSL
datapath dp(clk, reset,
            RegSrc, RegWrite, ImmSrc,
            ALUSrc, ALUControl,
            MemtoReg, PCSrc,
            ALUFlags, PC, Instr,
            ALUResult, WriteData, ReadData,
            carry, // ADC
            Shift); // LSL
endmodule

module controller(input  logic      clk, reset,
                 input  logic [31:12] Instr,
                 input  logic [3:0]  ALUFlags,
                 output logic [1:0]  RegSrc,
                 output logic        RegWrite,
                 output logic [1:0]  ImmSrc,
                 output logic        ALUSrc,
                 output logic [2:0]  ALUControl, // ADC
                 output logic        MemWrite, MemtoReg,
                 output logic        PCSrc,
                 output logic        carry, // ADC
                 output logic        Shift); // LSL

logic [1:0] FlagW;
logic      PCS, RegW, MemW;
logic      NoWrite; // TST, CMN

decoder dec(Instr[27:26], Instr[25:20], Instr[15:12],
            FlagW, PCS, RegW, MemW,
            MemtoReg, ALUSrc, ImmSrc, RegSrc, ALUControl,
            NoWrite, // TST, CMN
            Shift); // LSL
condlogic cl(clk, reset, Instr[31:28], ALUFlags,
            FlagW, PCS, RegW, MemW,
            PCSrc, RegWrite, MemWrite,
            carry, // ADC
            NoWrite); // TST, CMN
endmodule

module decoder(input  logic [1:0] Op,
              input  logic [5:0] Funct,
              input  logic [3:0] Rd,
              output logic [1:0] FlagW,

```



```

        output logic      PCS, RegW, MemW,
        output logic      MemtoReg, ALUSrc,
        output logic [1:0] ImmSrc, RegSrc,
        output logic [2:0] ALUControl, // ADC
        output logic      NoWrite,    // TST, CMN
        output logic      Shift);    // LSL
logic [9:0] controls;
logic      Branch, ALUOp;

// Main Decoder

always_comb
    case(Op)
        // Data processing immediate
        2'b00: if (Funct[5]) controls = 10'b0000101001;
        // Data processing register
        else controls = 10'b0000001001;
        // LDR
        2'b01: if (Funct[0]) controls = 10'b0001111000;
        // STR
        else controls = 10'b1001110100;
        // B
        2'b10: controls = 10'b0110100010;
        // Unimplemented
        default: controls = 10'bx;
    endcase

assign {RegSrc, ImmSrc, ALUSrc, MemtoReg,
        RegW, MemW, Branch, ALUOp} = controls;

// ALU Decoder
always_comb
    if (ALUOp) begin // which DP Instr?
        case(Funct[4:1])
            4'b0100: begin // ADD
                ALUControl = 3'b000;
                NoWrite = 1'b0;
                Shift = 1'b0;
            end
            4'b0010: begin // SUB
                ALUControl = 3'b001;
                NoWrite = 1'b0;
                Shift = 1'b0;
            end
            4'b0000: begin // AND
                ALUControl = 3'b010;
                NoWrite = 1'b0;
                Shift = 1'b0;
            end
            4'b1100: begin // OR
                ALUControl = 3'b011;
                NoWrite = 1'b0;
                Shift = 1'b0;
            end
        end
    end

```

```

4'b1000: begin                                // TST
    ALUControl = 3'b010;
    NoWrite = 1'b1;
    Shift = 1'b0;
end
4'b1101: begin                                // LSL
    ALUControl = 3'b000;
    NoWrite = 1'b0;
    Shift = 1'b1;
end
4'b1011: begin                                // CMN
    ALUControl = 3'b000;
    NoWrite = 1'b1;
    Shift = 1'b0;
end
4'b0101: begin                                // ADC
    ALUControl = 3'b100;
    NoWrite = 1'b0;
    Shift = 1'b0;
end
default: begin                                // unimplemented
    ALUControl = 3'bx;
    NoWrite = 1'bx;
    Shift = 1'bx;
end
endcase

// update flags if S bit is set
// (C & V only updated for arith instructions)
FlagW[1] = Funct[0]; // FlagW[1] = S-bit
// FlagW[0] = S-bit & (ADD | SUB)
FlagW[0] = Funct[0] &
    (ALUControl[1:0] == 2'b00 | ALUControl[1:0] == 2'b01);

end else begin
    ALUControl = 3'b000; // add for non-DP instructions
    FlagW = 2'b00; // don't update Flags
    NoWrite = 1'b0;
    Shift = 1'b0;
end

// PC Logic
assign PCS = ((Rd == 4'b1111) & RegW) | Branch;
endmodule

module condlogic(input logic clk, reset,
input logic [3:0] Cond,
input logic [3:0] ALUFlags,
input logic [1:0] FlagW,
input logic PCS, RegW, MemW,
output logic PCSrc, RegWrite, MemWrite,
output logic carry, // ADC

```

```

        input logic      NoWrite); // TST, CMN

logic [1:0] FlagWrite;
logic [3:0] Flags;
logic      CondEx;

flopnr #(2)flagreg1(clk, reset, FlagWrite[1],
                   ALUFlags[3:2], Flags[3:2]);
flopnr #(2)flagreg0(clk, reset, FlagWrite[0],
                   ALUFlags[1:0], Flags[1:0]);

// write controls are conditional
condcheck cc(Cond, Flags, CondEx);
assign FlagWrite = FlagW & {2{CondEx}};
assign RegWrite  = RegW  & CondEx & ~NoWrite; // TST, CMN
assign MemWrite  = MemW  & CondEx;
assign PCSrc     = PCS   & CondEx;

assign carry     = Flags[1]; // ADC
endmodule

module condcheck(input logic [3:0] Cond,
                 input logic [3:0] Flags,
                 output logic      CondEx);

logic neg, zero, carry, overflow, ge;

assign {neg, zero, carry, overflow} = Flags;
assign ge = (neg == overflow);

always_comb
  case(Cond)
    4'b0000: CondEx = zero;           // EQ
    4'b0001: CondEx = ~zero;         // NE
    4'b0010: CondEx = carry;         // CS
    4'b0011: CondEx = ~carry;        // CC
    4'b0100: CondEx = neg;           // MI
    4'b0101: CondEx = ~neg;          // PL
    4'b0110: CondEx = overflow;      // VS
    4'b0111: CondEx = ~overflow;     // VC
    4'b1000: CondEx = carry & ~zero; // HI
    4'b1001: CondEx = ~(carry & ~zero); // LS
    4'b1010: CondEx = ge;            // GE
    4'b1011: CondEx = ~ge;           // LT
    4'b1100: CondEx = ~zero & ge;    // GT
    4'b1101: CondEx = ~(~zero & ge); // LE
    4'b1110: CondEx = 1'b1;          // Always
    default: CondEx = 1'bx;          // undefined
  endcase
endmodule

module datapath(input logic      clk, reset,
                input logic [1:0] RegSrc,
                input logic      RegWrite,

```

```

        input  logic [1:0]  ImmSrc,
        input  logic      ALUSrc,
        input  logic [2:0]  ALUControl,      // ADC
        input  logic      MemtoReg,
        input  logic      PCSrc,
        output logic [3:0]  ALUFlags,
        output logic [31:0] PC,
        input  logic [31:0] Instr,
        output logic [31:0] ALUResultOut,    // LSL
        output logic [31:0] WriteData,
        input  logic [31:0] ReadData,
        input  logic      carry,            // ADC
        input  logic      Shift);          // LSL

logic [31:0] PCNext, PCPlus4, PCPlus8;
logic [31:0] ExtImm, SrcA, SrcB, Result;
logic [3:0]  RA1, RA2;
logic [31:0] srcBshifted, ALUResult; // LSL

// next PC logic
mux2 #(32)  pcmux(PCPlus4, Result, PCSrc, PCNext);
flop #(32)  pcreg(clk, reset, PCNext, PC);
adder #(32) pcadd1(PC, 32'b100, PCPlus4);
adder #(32) pcadd2(PCPlus4, 32'b100, PCPlus8);

// register file logic
mux2 #(4)   ralmux(Instr[19:16], 4'b1111, RegSrc[0], RA1);
mux2 #(4)   ra2mux(Instr[3:0], Instr[15:12], RegSrc[1], RA2);
regfile     rf(clk, RegWrite, RA1, RA2,
               Instr[15:12], Result, PCPlus8,
               SrcA, WriteData);
mux2 #(32)  resmux(ALUResultOut, ReadData, MemtoReg, Result);
extend      ext(Instr[23:0], ImmSrc, ExtImm);

// ALU logic
shifter     sh(WriteData, Instr[11:7], Instr[6:5], srcBshifted); // LSL
mux2 #(32)  srcbmux(srcBshifted, ExtImm, ALUSrc, SrcB); // LSL
alu         alu(SrcA, SrcB, ALUControl,
               ALUResult, ALUFlags,
               carry); // ADC
mux2 #(32)  aluresultmux(ALUResult, SrcB, Shift, ALUResultOut); // LSL

endmodule

module regfile(input  logic      clk,
               input  logic      we3,
               input  logic [3:0] ra1, ra2, wa3,
               input  logic [31:0] wd3, r15,
               output logic [31:0] rd1, rd2);

logic [31:0] rf[14:0];

// three ported register file
// read two ports combinationaly

```

```

// write third port on rising edge of clock
// register 15 reads PC+8 instead

always_ff @(posedge clk)
    if (we3) rf[wa3] <= wd3;

assign rd1 = (ra1 == 4'b1111) ? r15 : rf[ra1];
assign rd2 = (ra2 == 4'b1111) ? r15 : rf[ra2];
endmodule

module extend(input  logic [23:0] Instr,
              input  logic [1:0] ImmSrc,
              output logic [31:0] ExtImm);

always_comb
    case(ImmSrc)
        // 8-bit unsigned immediate
        2'b00: ExtImm = {24'b0, Instr[7:0]};
        // 12-bit unsigned immediate
        2'b01: ExtImm = {20'b0, Instr[11:0]};
        // 24-bit two's complement shifted branch
        2'b10: ExtImm = {{6{Instr[23]}}, Instr[23:0], 2'b00};
        default: ExtImm = 32'bx; // undefined
    endcase
endmodule

module adder #(parameter WIDTH=8)
    (input  logic [WIDTH-1:0] a, b,
     output logic [WIDTH-1:0] y);

    assign y = a + b;
endmodule

module flopenr #(parameter WIDTH = 8)
    (input  logic          clk, reset, en,
     input  logic [WIDTH-1:0] d,
     output logic [WIDTH-1:0] q);

    always_ff @(posedge clk, posedge reset)
        if (reset) q <= 0;
        else if (en) q <= d;
endmodule

module flopr #(parameter WIDTH = 8)
    (input  logic          clk, reset,
     input  logic [WIDTH-1:0] d,
     output logic [WIDTH-1:0] q);

    always_ff @(posedge clk, posedge reset)
        if (reset) q <= 0;
        else      q <= d;
endmodule

module mux2 #(parameter WIDTH = 8)

```

```

        (input  logic [WIDTH-1:0] d0, d1,
         input  logic          s,
         output logic [WIDTH-1:0] y);

    assign y = s ? d1 : d0;
endmodule

module alu(input  logic [31:0] a, b,
           input  logic [2:0] ALUControl,           // ADC
           output logic [31:0] Result,
           output logic [3:0] ALUFlags,
           input  logic          carry);           // ADC

    logic          neg, zero, carryout, overflow;
    logic [31:0]  condinvb;
    logic [32:0]  sum;
    logic          carryin;                       // ADC

    assign carryin = ALUControl[2] ? carry : ALUControl[0]; // ADC
    assign condinvb = ALUControl[0] ? ~b : b;
    assign sum = a + condinvb + carryin;           // ADC

    always_comb
        casex (ALUControl[1:0])
            2'b0?: Result = sum;
            2'b10: Result = a & b;
            2'b11: Result = a | b;
        endcase

    assign neg      = Result[31];
    assign zero     = (Result == 32'b0);
    assign carryout = (ALUControl[1] == 1'b0) & sum[32];
    assign overflow = (ALUControl[1] == 1'b0) &
        ~(a[31] ^ b[31] ^ ALUControl[0]) &
        (a[31] ^ sum[31]);
    assign ALUFlags = {neg, zero, carryout, overflow};
endmodule

// shifter needed for LSL
module shifter(input  logic [31:0] a,
               input  logic [ 4:0] shamt,
               input  logic [ 1:0] shtype,
               output logic [31:0] y);

    always_comb
        case (shtype)
            2'b00: y = a << shamt;
            default: y = a;
        endcase
endmodule

```

```

library IEEE;
use IEEE.STD_LOGIC_1164.all; use IEEE.NUMERIC_STD_UNSIGNED.all;
entity testbench is
end;

architecture test of testbench is
  component top
    port (clk, reset:          in  STD_LOGIC;
          WriteData, DataAdr: out STD_LOGIC_VECTOR(31 downto 0);
          MemWrite:           out STD_LOGIC);
  end component;
  signal WriteData, DataAdr:  STD_LOGIC_VECTOR(31 downto 0);
  signal clk, reset, MemWrite: STD_LOGIC;
begin

  -- instantiate device to be tested
  dut: top port map (clk, reset, WriteData, DataAdr, MemWrite);

  -- Generate clock with 10 ns period
  process begin
    clk <= '1';
    wait for 5 ns;
    clk <= '0';
    wait for 5 ns;
  end process;

  -- Generate reset for first two clock cycles
  process begin
    reset <= '1';
    wait for 22 ns;
    reset <= '0';
    wait;
  end process;

  -- check that 0x80000001 gets written to address 20
  -- at end of program
  process (clk) begin
    if (clk'event and clk = '0' and MemWrite = '1') then
      if (to_integer(DataAdr) = 20 and
          to_integer(WriteData) = 2) then
        report "NO ERRORS: Simulation succeeded" severity failure;
      else
        report "Simulation failed" severity failure;
      end if;
    end if;
  end process;
end;

library IEEE;
use IEEE.STD_LOGIC_1164.all; use IEEE.NUMERIC_STD_UNSIGNED.all;
entity top is -- top-level design for testing
  port (clk, reset:          in  STD_LOGIC;
        WriteData, DataAdr:  buffer STD_LOGIC_VECTOR(31 downto 0);
        MemWrite:           buffer STD_LOGIC);
end;

```

```

end;

architecture test of top is
  component arm
    port(clk, reset:      in  STD_LOGIC;
         PC:              out STD_LOGIC_VECTOR(31 downto 0);
         Instr:           in  STD_LOGIC_VECTOR(31 downto 0);
         MemWrite:        out STD_LOGIC;
         ALUResult, WriteData: out STD_LOGIC_VECTOR(31 downto 0);
         ReadData:        in  STD_LOGIC_VECTOR(31 downto 0));
  end component;
  component imem
    port(a: in  STD_LOGIC_VECTOR(31 downto 0);
         rd: out STD_LOGIC_VECTOR(31 downto 0));
  end component;
  component dmem
    port(clk, we: in  STD_LOGIC;
         a, wd:  in  STD_LOGIC_VECTOR(31 downto 0);
         rd:    out STD_LOGIC_VECTOR(31 downto 0));
  end component;
  signal PC, Instr,
         ReadData: STD_LOGIC_VECTOR(31 downto 0);
begin
  -- instantiate processor and memories
  i_arm: arm port map(clk, reset, PC, Instr, MemWrite, DataAdr,
                    WriteData, ReadData);
  i_imem: imem port map(PC, Instr);
  i_dmem: dmem port map(clk, MemWrite, DataAdr,
                    WriteData, ReadData);
end;

library IEEE;
use IEEE.STD_LOGIC_1164.all; use STD.TEXTIO.all;
use IEEE.NUMERIC_STD_UNSIGNED.all;
entity dmem is -- data memory
  port(clk, we: in  STD_LOGIC;
       a, wd:  in  STD_LOGIC_VECTOR(31 downto 0);
       rd:    out STD_LOGIC_VECTOR(31 downto 0));
end;

architecture behave of dmem is
begin
  process is
    type ramtype is array (63 downto 0) of
      STD_LOGIC_VECTOR(31 downto 0);
    variable mem: ramtype;
  begin -- read or write memory
    loop
      if clk'event and clk = '1' then
        if (we = '1') then
          mem(to_integer(a(7 downto 2))) := wd;
        end if;
      end if;
      rd <= mem(to_integer(a(7 downto 2)));
    end loop;
  end process;
end;

```



```

        wait on clk, a;
    end loop;
end process;
end;

library IEEE;
use IEEE.STD_LOGIC_1164.all; use STD.TEXTIO.all;
use IEEE.NUMERIC_STD_UNSIGNED.all;
entity imem is -- instruction memory
    port(a: in STD_LOGIC_VECTOR(31 downto 0);
         rd: out STD_LOGIC_VECTOR(31 downto 0));
end;
architecture behave of imem is -- instruction memory
begin
    process is
        file mem_file: TEXT;
        variable L: line;
        variable ch: character;
        variable i, index, result: integer;
        type ramtype is array (63 downto 0) of
            STD_LOGIC_VECTOR(31 downto 0);
        variable mem: ramtype;
    begin
        -- initialize memory from file
        for i in 0 to 63 loop -- set all contents low
            mem(i) := (others => '0');
        end loop;
        index := 0;
        FILE_OPEN(mem_file, "ex7.9_memfile.dat", READ_MODE);
        while not endfile(mem_file) loop
            readline(mem_file, L);
            result := 0;
            for i in 1 to 8 loop
                read(L, ch);
                if '0' <= ch and ch <= '9' then
                    result := character'pos(ch) - character'pos('0');
                elsif 'a' <= ch and ch <= 'f' then
                    result := character'pos(ch) - character'pos('a')+10;
                elsif 'A' <= ch and ch <= 'F' then
                    result := character'pos(ch) - character'pos('A')+10;
                else report "Format error on line " & integer'image(index)
                    severity error;
                end if;
                mem(index)(35-i*4 downto 32-i*4) :=
                    to_std_logic_vector(result,4);
            end loop;
            index := index + 1;
        end loop;

        -- read memory
        loop
            rd <= mem(to_integer(a(7 downto 2)));
            wait on a;
        end loop;
    end process;
end;

```

```

    end process;
end;

library IEEE; use IEEE.STD_LOGIC_1164.all;
entity arm is -- single cycle processor
    port (clk, reset:      in  STD_LOGIC;
          PC:              out STD_LOGIC_VECTOR(31 downto 0);
          Instr:           in  STD_LOGIC_VECTOR(31 downto 0);
          MemWrite:        out STD_LOGIC;
          ALUResult, WriteData: out STD_LOGIC_VECTOR(31 downto 0);
          ReadData:        in  STD_LOGIC_VECTOR(31 downto 0));
end;

architecture struct of arm is
    component controller
        port (clk, reset:      in  STD_LOGIC;
              Instr:           in  STD_LOGIC_VECTOR(31 downto 12);
              ALUFlags:        in  STD_LOGIC_VECTOR(3 downto 0);
              RegSrc:          out STD_LOGIC_VECTOR(1 downto 0);
              RegWrite:        out STD_LOGIC;
              ImmSrc:          out STD_LOGIC_VECTOR(1 downto 0);
              ALUSrc:          out STD_LOGIC;
              ALUControl:      out STD_LOGIC_VECTOR(2 downto 0);      -- ADC
              MemWrite:        out STD_LOGIC;
              MemtoReg:        out STD_LOGIC;
              PCSrc:           out STD_LOGIC;
              carry:           out STD_LOGIC;      -- ADC
              Shift:           out STD_LOGIC);      -- LSL
    end component;
    component datapath
        port (clk, reset:      in  STD_LOGIC;
              RegSrc:          in  STD_LOGIC_VECTOR(1 downto 0);
              RegWrite:        in  STD_LOGIC;
              ImmSrc:          in  STD_LOGIC_VECTOR(1 downto 0);
              ALUSrc:          in  STD_LOGIC;
              ALUControl:      in  STD_LOGIC_VECTOR(2 downto 0);      -- ADC
              MemtoReg:        in  STD_LOGIC;
              PCSrc:           in  STD_LOGIC;
              ALUFlags:        out STD_LOGIC_VECTOR(3 downto 0);
              PC:              buffer STD_LOGIC_VECTOR(31 downto 0);
              Instr:           in  STD_LOGIC_VECTOR(31 downto 0);
              ALUResultOut:    buffer STD_LOGIC_VECTOR(31 downto 0);  -- LSL
              WriteData:       buffer STD_LOGIC_VECTOR(31 downto 0);
              ReadData:        in  STD_LOGIC_VECTOR(31 downto 0);
              carry:           in  STD_LOGIC;      -- ADC
              Shift:           in  STD_LOGIC);      -- LSL
    end component;
    signal ALUFlags: STD_LOGIC_VECTOR(3 downto 0);
    signal RegWrite, ALUSrc, MemtoReg, PCSrc: STD_LOGIC;
    signal RegSrc, ImmSrc: STD_LOGIC_VECTOR(1 downto 0);
    signal ALUControl: STD_LOGIC_VECTOR(2 downto 0);      -- ADC
    signal carry: STD_LOGIC;      -- ADC
    signal Shift: STD_LOGIC;      -- LSL
begin

```

```

cont: controller port map(clk, reset, Instr(31 downto 12),
                          ALUFlags, RegSrc, RegWrite, ImmSrc,
                          ALUSrc, ALUControl, MemWrite,
                          MemtoReg, PCSrc,
                          carry, -- ADC
                          Shift); -- LSL
dp: datapath port map(clk, reset, RegSrc, RegWrite, ImmSrc,
                      ALUSrc, ALUControl, MemtoReg, PCSrc,
                      ALUFlags, PC, Instr, ALUResult,
                      WriteData, ReadData,
                      carry, -- ADC
                      Shift); -- LSL
end;

library IEEE; use IEEE.STD_LOGIC_1164.all;
entity controller is -- single cycle control decoder
  port(clk, reset:      in  STD_LOGIC;
        Instr:         in  STD_LOGIC_VECTOR(31 downto 12);
        ALUFlags:      in  STD_LOGIC_VECTOR(3 downto 0);
        RegSrc:        out STD_LOGIC_VECTOR(1 downto 0);
        RegWrite:      out STD_LOGIC;
        ImmSrc:        out STD_LOGIC_VECTOR(1 downto 0);
        ALUSrc:        out STD_LOGIC;
        ALUControl:    out STD_LOGIC_VECTOR(2 downto 0); -- ADC
        MemWrite:      out STD_LOGIC;
        MemtoReg:      out STD_LOGIC;
        PCSrc:         out STD_LOGIC;
        carry:         out STD_LOGIC; -- ADC
        Shift:         out STD_LOGIC); -- LSL
end;

architecture struct of controller is
  component decoder
    port(Op:           in  STD_LOGIC_VECTOR(1 downto 0);
          Funct:       in  STD_LOGIC_VECTOR(5 downto 0);
          Rd:          in  STD_LOGIC_VECTOR(3 downto 0);
          FlagW:       out STD_LOGIC_VECTOR(1 downto 0);
          PCS, RegW, MemW: out STD_LOGIC;
          MemtoReg, ALUSrc: out STD_LOGIC;
          ImmSrc, RegSrc: out STD_LOGIC_VECTOR(1 downto 0);
          ALUControl:  out STD_LOGIC_VECTOR(2 downto 0); -- ADC
          NoWrite:     out STD_LOGIC; -- TST, CMN
          Shift:       out STD_LOGIC); -- LSL
  end component;
  component condlogic
    port(clk, reset:  in  STD_LOGIC;
          Cond:       in  STD_LOGIC_VECTOR(3 downto 0);
          ALUFlags:   in  STD_LOGIC_VECTOR(3 downto 0);
          FlagW:      in  STD_LOGIC_VECTOR(1 downto 0);
          PCS, RegW, MemW: in STD_LOGIC;
          PCSrc, RegWrite: out STD_LOGIC;
          MemWrite:   out STD_LOGIC;
          carry:      out STD_LOGIC; -- ADC
          NoWrite:    in  STD_LOGIC); -- TST, CMN
  end component;

```

```

end component;
signal FlagW: STD_LOGIC_VECTOR(1 downto 0);
signal PCS, RegW, MemW: STD_LOGIC;
signal NoWrite: STD_LOGIC; -- TST, CMN
begin
  dec: decoder port map(Instr(27 downto 26), Instr(25 downto 20),
    Instr(15 downto 12), FlagW, PCS,
    RegW, MemW, MemtoReg, ALUSrc, ImmSrc,
    RegSrc, ALUControl,
    NoWrite,      -- TST, CMN
    Shift);      -- LSL
  cl: condlogic port map(clk, reset, Instr(31 downto 28),
    ALUFlags, FlagW, PCS, RegW, MemW,
    PCSrc, RegWrite, MemWrite,
    carry,      -- ADC
    NoWrite); -- TST, CMN
end;

library IEEE; use IEEE.STD_LOGIC_1164.all;
entity decoder is -- main control decoder
  port(Op:          in  STD_LOGIC_VECTOR(1 downto 0);
        Funct:     in  STD_LOGIC_VECTOR(5 downto 0);
        Rd:        in  STD_LOGIC_VECTOR(3 downto 0);
        FlagW:     out STD_LOGIC_VECTOR(1 downto 0);
        PCS, RegW, MemW: out STD_LOGIC;
        MemtoReg, ALUSrc: out STD_LOGIC;
        ImmSrc, RegSrc: out STD_LOGIC_VECTOR(1 downto 0);
        ALUControl: out STD_LOGIC_VECTOR(2 downto 0); -- ADC
        NoWrite:    out STD_LOGIC;                    -- TST, CMN
        Shift:     out STD_LOGIC);                    -- LSL
end;

architecture behave of decoder is
  signal controls: STD_LOGIC_VECTOR(9 downto 0);
  signal ALUOp, Branch: STD_LOGIC;
  signal op2: STD_LOGIC_VECTOR(3 downto 0);
begin
  op2 <= (Op, Funct(5), Funct(0));
  process(all) begin -- Main Decoder
    case? (op2) is
      when "000-" => controls <= "0000001001";
      when "001-" => controls <= "0000101001";
      when "01-0" => controls <= "1001110100";
      when "01-1" => controls <= "0001111000";
      when "10--" => controls <= "0110100010";
      when others => controls <= "-----";
    end case?;
  end process;

  (RegSrc, ImmSrc, ALUSrc, MemtoReg, RegW, MemW,
   Branch, ALUOp) <= controls;

  process(all) begin -- ALU Decoder
    if (ALUOp) then

```

```

case Funct(4 downto 1) is
  when "0100" => ALUControl <= "000"; -- ADD
                 NoWrite <= '0';
                 Shift <= '0';
  when "0010" => ALUControl <= "001"; -- SUB
                 NoWrite <= '0';
                 Shift <= '0';
  when "0000" => ALUControl <= "010"; -- AND
                 NoWrite <= '0';
                 Shift <= '0';
  when "1100" => ALUControl <= "011"; -- ORR
                 NoWrite <= '0';
                 Shift <= '0';
  when "1000" => ALUControl <= "010"; -- TST
                 NoWrite <= '1';
                 Shift <= '0';
  when "1101" => ALUControl <= "000"; -- LSL
                 NoWrite <= '0';
                 Shift <= '1';
  when "1011" => ALUControl <= "000"; -- CMN
                 NoWrite <= '1';
                 Shift <= '0';
  when "0101" => ALUControl <= "100"; -- ADC
                 NoWrite <= '0';
                 Shift <= '0';
  when others => ALUControl <= "----"; -- unimplemented
                 NoWrite <= '-';
                 Shift <= '-';

end case;
FlagW(1) <= Funct(0);
FlagW(0) <= Funct(0) and (not ALUControl(1));
else
  ALUControl <= "000";
  NoWrite <= '0';
  Shift <= '0';
  FlagW <= "00";
end if;
end process;

PCS <= ((and Rd) and RegW) or Branch;
end;

library IEEE; use IEEE.STD_LOGIC_1164.all;
entity condlogic is -- Conditional logic
  port (clk, reset:      in  STD_LOGIC;
        Cond:           in  STD_LOGIC_VECTOR(3 downto 0);
        ALUFlags:       in  STD_LOGIC_VECTOR(3 downto 0);
        FlagW:          in  STD_LOGIC_VECTOR(1 downto 0);
        PCS, RegW, MemW: in  STD_LOGIC;
        PCSrc, RegWrite: out STD_LOGIC;
        MemWrite:        out STD_LOGIC;
        carry:           out STD_LOGIC; -- ADC
        NoWrite:         in  STD_LOGIC); -- TST, CMN
end;

```

```

architecture behave of condlogic is
  component condcheck
    port(Cond:          in  STD_LOGIC_VECTOR(3 downto 0);
         Flags:        in  STD_LOGIC_VECTOR(3 downto 0);
         CondEx:       out STD_LOGIC);
  end component;
  component flopenr generic(width: integer);
    port(clk, reset, en: in  STD_LOGIC;
         d:          in  STD_LOGIC_VECTOR(width-1 downto 0);
         q:          out STD_LOGIC_VECTOR(width-1 downto 0));
  end component;
  signal FlagWrite: STD_LOGIC_VECTOR(1 downto 0);
  signal Flags:    STD_LOGIC_VECTOR(3 downto 0);
  signal CondEx:   STD_LOGIC;
begin
  flagreg1: flopenr generic map(2)
    port map(clk, reset, FlagWrite(1),
             ALUFlags(3 downto 2), Flags(3 downto 2));
  flagreg0: flopenr generic map(2)
    port map(clk, reset, FlagWrite(0),
             ALUFlags(1 downto 0), Flags(1 downto 0));
  cc: condcheck port map(Cond, Flags, CondEx);

  FlagWrite <= FlagW and (CondEx, CondEx);
  RegWrite  <= RegW  and CondEx and (not NoWrite); -- TST, CMN
  MemWrite  <= MemW  and CondEx;
  PCSrc     <= PCS   and CondEx;

  carry <= Flags(1); -- ADC
end;

library IEEE; use IEEE.STD_LOGIC_1164.all;
entity condcheck is
  port(Cond:          in  STD_LOGIC_VECTOR(3 downto 0);
       Flags:        in  STD_LOGIC_VECTOR(3 downto 0);
       CondEx:       out STD_LOGIC);
end;

architecture behave of condcheck is
  signal neg, zero, carry, overflow, ge: STD_LOGIC;
begin
  (neg, zero, carry, overflow) <= Flags;
  ge <= (neg xnor overflow);

  process(all) begin -- Condition checking
    case Cond is
      when "0000" => CondEx <= zero;
      when "0001" => CondEx <= not zero;
      when "0010" => CondEx <= carry;
      when "0011" => CondEx <= not carry;
      when "0100" => CondEx <= neg;
      when "0101" => CondEx <= not neg;
      when "0110" => CondEx <= overflow;
    end case;
  end process;
end;

```

```

when "0111" => CondEx <= not overflow;
when "1000" => CondEx <= carry and (not zero);
when "1001" => CondEx <= not(carry and (not zero));
when "1010" => CondEx <= ge;
when "1011" => CondEx <= not ge;
when "1100" => CondEx <= (not zero) and ge;
when "1101" => CondEx <= not ((not zero) and ge);
when "1110" => CondEx <= '1';
when others => CondEx <= '-';
end case;
end process;
end;

library IEEE; use IEEE.STD_LOGIC_1164.all;
entity datapath is
  port(clk, reset:      in  STD_LOGIC;
        RegSrc:         in  STD_LOGIC_VECTOR(1 downto 0);
        RegWrite:       in  STD_LOGIC;
        ImmSrc:         in  STD_LOGIC_VECTOR(1 downto 0);
        ALUSrc:         in  STD_LOGIC;
        ALUControl:     in  STD_LOGIC_VECTOR(2 downto 0);      -- ADC
        MemtoReg:       in  STD_LOGIC;
        PCSrc:          in  STD_LOGIC;
        ALUFlags:       out STD_LOGIC_VECTOR(3 downto 0);
        PC:              buffer STD_LOGIC_VECTOR(31 downto 0);
        Instr:          in  STD_LOGIC_VECTOR(31 downto 0);
        ALUResultOut:   buffer STD_LOGIC_VECTOR(31 downto 0);  -- LSL
        WriteData:      buffer STD_LOGIC_VECTOR(31 downto 0);
        ReadData:       in  STD_LOGIC_VECTOR(31 downto 0);
        carry:          in  STD_LOGIC;                          -- ADC
        Shift:          in  STD_LOGIC);                          -- LSL
end;

architecture struct of datapath is
  component alu
    port(a, b:          in  STD_LOGIC_VECTOR(31 downto 0);
          ALUControl: in  STD_LOGIC_VECTOR(2 downto 0);  -- ADC
          Result:      buffer STD_LOGIC_VECTOR(31 downto 0);
          ALUFlags:   out  STD_LOGIC_VECTOR(3 downto 0);
          carry:      in  STD_LOGIC);                    -- ADC
  end component;
  component regfile
    port(clk:          in  STD_LOGIC;
          we3:         in  STD_LOGIC;
          ra1, ra2, wa3: in  STD_LOGIC_VECTOR(3 downto 0);
          wd3, r15:    in  STD_LOGIC_VECTOR(31 downto 0);
          rd1, rd2:    out  STD_LOGIC_VECTOR(31 downto 0));
  end component;
  component adder
    port(a, b: in  STD_LOGIC_VECTOR(31 downto 0);
          y:   out STD_LOGIC_VECTOR(31 downto 0));
  end component;
  component extend
    port(Instr: in  STD_LOGIC_VECTOR(23 downto 0);

```

```

        ImmSrc: in  STD_LOGIC_VECTOR(1 downto 0);
        ExtImm: out STD_LOGIC_VECTOR(31 downto 0));
end component;
component flopr generic(width: integer);
port(clk, reset: in  STD_LOGIC;
      d:          in  STD_LOGIC_VECTOR(width-1 downto 0);
      q:          out STD_LOGIC_VECTOR(width-1 downto 0));
end component;
component mux2 generic(width: integer);
port(d0, d1: in  STD_LOGIC_VECTOR(width-1 downto 0);
      s:      in  STD_LOGIC;
      y:      out STD_LOGIC_VECTOR(width-1 downto 0));
end component;
component shifter -- LSL
port(a:      in  STD_LOGIC_VECTOR(31 downto 0);
      shamt: in  STD_LOGIC_VECTOR(4  downto 0);
      shtype: in  STD_LOGIC_VECTOR(1  downto 0);
      y:      out STD_LOGIC_VECTOR(31 downto 0));
end component;

signal PCNext, PCPlus4, PCPlus8: STD_LOGIC_VECTOR(31 downto 0);
signal ExtImm, Result:          STD_LOGIC_VECTOR(31 downto 0);
signal SrcA, SrcB:              STD_LOGIC_VECTOR(31 downto 0);
signal RA1, RA2:                STD_LOGIC_VECTOR(3  downto 0);
signal srcBshifted, ALUResult:  STD_LOGIC_VECTOR(31 downto 0); -- LSL
begin
-- next PC logic
pcmux: mux2 generic map(32)
        port map(PCPlus4, Result, PCSrc, PCNext);
pcreg: flopr generic map(32) port map(clk, reset, PCNext, PC);
pcadd1: adder port map(PC, X"00000004", PCPlus4);
pcadd2: adder port map(PCPlus4, X"00000004", PCPlus8);

-- register file logic
ralmux: mux2 generic map (4)
        port map(Instr(19 downto 16), "1111", RegSrc(0), RA1);
ra2mux: mux2 generic map (4) port map(Instr(3  downto 0),
        Instr(15 downto 12), RegSrc(1), RA2);
rf: regfile port map(clk, RegWrite, RA1, RA2,
        Instr(15 downto 12), Result,
        PCPlus8, SrcA, WriteData);
resmux: mux2 generic map(32)
        port map(ALUResult, ReadData, MemtoReg, Result);
ext: extend port map(Instr(23 downto 0), ImmSrc, ExtImm);

-- ALU logic
sh: shifter port map(WriteData, Instr(11 downto 7), Instr(6  downto 5),
srcBshifted); -- LSL
srcbmux: mux2 generic map(32)
        port map(srcBshifted, ExtImm, ALUSrc, SrcB); -- LSL
i_alu: alu port map(SrcA, SrcB, ALUControl, ALUResult, ALUFlags,
        carry); -- ADC
aluresultmux: mux2 generic map(32)
        port map(ALUResult, SrcB, Shift, ALUResultOut); -- LSL

```



```

end;

library IEEE; use IEEE.STD_LOGIC_1164.all;
use IEEE.NUMERIC_STD_UNSIGNED.all;
entity regfile is -- three-port register file
  port (clk:          in  STD_LOGIC;
        we3:         in  STD_LOGIC;
        ra1, ra2, wa3: in  STD_LOGIC_VECTOR(3 downto 0);
        wd3, r15:    in  STD_LOGIC_VECTOR(31 downto 0);
        rd1, rd2:    out STD_LOGIC_VECTOR(31 downto 0));
end;

architecture behave of regfile is
  type ramtype is array (31 downto 0) of
    STD_LOGIC_VECTOR(31 downto 0);
  signal mem: ramtype;
begin
  process (clk) begin
    if rising_edge (clk) then
      if we3 = '1' then mem (to_integer (wa3)) <= wd3;
      end if;
    end if;
  end process;
  process (all) begin
    if (to_integer (ra1) = 15) then rd1 <= r15;
    else rd1 <= mem (to_integer (ra1));
    end if;
    if (to_integer (ra2) = 15) then rd2 <= r15;
    else rd2 <= mem (to_integer (ra2));
    end if;
  end process;
end;

library IEEE; use IEEE.STD_LOGIC_1164.all;
use IEEE.NUMERIC_STD_UNSIGNED.all;
entity adder is -- adder
  port (a, b: in  STD_LOGIC_VECTOR(31 downto 0);
        y:   out STD_LOGIC_VECTOR(31 downto 0));
end;

architecture behave of adder is
begin
  y <= a + b;
end;

library IEEE; use IEEE.STD_LOGIC_1164.all;
entity extend is
  port (Instr: in  STD_LOGIC_VECTOR(23 downto 0);
        ImmSrc: in  STD_LOGIC_VECTOR(1 downto 0);
        ExtImm: out STD_LOGIC_VECTOR(31 downto 0));
end;

architecture behave of extend is
begin

```

```

process(all) begin
  case ImmSrc is
    when "00"  => ExtImm <= (X"000000", Instr(7 downto 0));
    when "01"  => ExtImm <= (X"00000", Instr(11 downto 0));
    when "10"  => ExtImm <= (Instr(23), Instr(23), Instr(23),
      Instr(23), Instr(23), Instr(23), Instr(23), Instr(23 downto 0), "00");
    when others => ExtImm <= X"-----";
  end case;
end process;
end;

```

```

library IEEE; use IEEE.STD_LOGIC_1164.all;
entity flopenr is -- flip-flop with enable and asynchronous reset
  generic(width: integer);
  port(clk, reset, en: in  STD_LOGIC;
        d:          in  STD_LOGIC_VECTOR(width-1 downto 0);
        q:          out STD_LOGIC_VECTOR(width-1 downto 0));
end;

```

```

architecture asynchronous of flopenr is
begin
  process(clk, reset) begin
    if reset then q <= (others => '0');
    elsif rising_edge(clk) then
      if en then
        q <= d;
      end if;
    end if;
  end process;
end;

```

```

library IEEE; use IEEE.STD_LOGIC_1164.all;
entity flopr is -- flip-flop with asynchronous reset
  generic(width: integer);
  port(clk, reset: in  STD_LOGIC;
        d:          in  STD_LOGIC_VECTOR(width-1 downto 0);
        q:          out STD_LOGIC_VECTOR(width-1 downto 0));
end;

```

```

architecture asynchronous of flopr is
begin
  process(clk, reset) begin
    if reset then q <= (others => '0');
    elsif rising_edge(clk) then
      q <= d;
    end if;
  end process;
end;

```

```

library IEEE; use IEEE.STD_LOGIC_1164.all;
entity mux2 is -- two-input multiplexer
  generic(width: integer);
  port(d0, d1: in  STD_LOGIC_VECTOR(width-1 downto 0);
        s:      in  STD_LOGIC;

```

```

        y:      out STD_LOGIC_VECTOR(width-1 downto 0));
end;

architecture behave of mux2 is
begin
    y <= d1 when s else d0;
end;

library IEEE; use IEEE.STD_LOGIC_1164.all;
use IEEE.NUMERIC_STD_UNSIGNED.all;
entity alu is
    port(a, b:      in      STD_LOGIC_VECTOR(31 downto 0);
          ALUControl: in      STD_LOGIC_VECTOR(2 downto 0);      -- ADC
          Result:   buffer STD_LOGIC_VECTOR(31 downto 0);
          ALUFlags: out      STD_LOGIC_VECTOR(3 downto 0);
          carry:    in      STD_LOGIC);                          -- ADC
end;

architecture behave of alu is
    signal condinvb:          STD_LOGIC_VECTOR(31 downto 0);
    signal sum:              STD_LOGIC_VECTOR(32 downto 0);
    signal neg, zero, carryout, overflow: STD_LOGIC;
    signal carryin:          STD_LOGIC;                          -- ADC
begin
    carryin <= carry when ALUControl(2) else ALUControl(0);      -- ADC
    condinvb <= not b when ALUControl(0) else b;
    sum <= ('0', a) + ('0', condinvb) + carryin;                  -- ADC

    process(all) begin
        case? ALUControl(1 downto 0) is
            when "0-" => result <= sum(31 downto 0);
            when "10" => result <= a and b;
            when "11" => result <= a or b;
            when others => result <= (others => '-');
        end case?;
    end process;

    neg      <= Result(31);
    zero     <= '1' when (Result = 0) else '0';
    carryout <= (not ALUControl(1)) and sum(32);
    overflow <= (not ALUControl(1)) and
                (not (a(31) xor b(31) xor ALUControl(0))) and
                (a(31) xor sum(31));
    ALUFlags <= (neg, zero, carryout, overflow);
end;

-- shifter needed for LSL
library IEEE; use IEEE.STD_LOGIC_1164.all;
use IEEE.NUMERIC_STD_UNSIGNED.all;
entity shifter is
    port(a:      in      STD_LOGIC_VECTOR(31 downto 0);
          shamt:  in      STD_LOGIC_VECTOR(4  downto 0);

```

```

        shtype: in STD_LOGIC_VECTOR(1 downto 0);
        y:      out STD_LOGIC_VECTOR(31 downto 0));
end;
architecture behave of shifter is
begin
    process (all) begin
        case shtype is
            when "00" => y <= TO_STDLOGICVECTOR(TO_BITVECTOR(a) sll
TO_INTEGER(shamt));
            when others => y <= a;
        end case;
    end process;
end;

```

### Test ARM assembly code:

; If successful, it should write the value 2 to address 20

```

MAIN
    SUB R3, PC, PC          ; R3 = 0
    ADD R3, R3, #1         ; R3 = 0x1
    LSL R3, R3, #30        ; R3 = 0x80000000
    ADD R4, R3, #1         ; R4 = 0x80000001
    CMN R3, R4             ; set flags according to R3+R4: NZCV=0011
    ADC R3, R3, #5         ; R3 = 0x80000006
    TST R3, R4             ; set NZ flags according to R3&R4: NZCV=1011
    LSL R3, R3, #1         ; R3 = 0x0000000c
    LSL R4, R4, #1         ; R4 = 0x00000002
    STRVC R4, [R3, #4]     ; mem[16]<=0x2 if V=0:
                          ; shouldn't happen
    STRVS R4, [R3, #8]     ; mem[20]<=0x2 if V=1: should happen

; E04F300F SUB R3,PC,PC
; E2833001 ADD R3,R3,#0x00000001
; E1A03F83 LSL R3,R3,#31
; E2834001 ADD R4,R3,#0x00000001
; E1730004 CMN R3,R4
; E2A33005 ADC R3,R3,#0x00000005
; E1130004 TST R3,R4
; E1A03083 LSL R3,R3,#1
; E1A04084 LSL R4,R4,#1
; 75834004 STRVC R4,[R3,#0x0004]
; 65834008 STRVS R4,[R3,#0x0008]

```

### ex7.9\_memfile.dat

```

E04F300F
E2833001
E1A03F83
E2834001
E1730004
E2A33005
E1130004
E1A03083

```

E1A04084  
 75834004  
 65834008

**Exercise 7.11**

---

- (a) STR: it stores the value in the register specified by bits 3:0 (Rm) instead of bits 15:12 (Rd).
- (b) LDR, STR: the memory always reads the value at the address specified by the PC, instead of a data memory address.
- (c) All instructions. PC+4 is never written to the PC register.

**Exercise 7.13**

---

- (a) ASR

ALU Decoder truth table

<i>ALUOp</i>	<i>Funct<sub>4:1</sub> (cmd)</i>	<i>Funct<sub>0</sub> (S)</i>	Notes	<i>ALUControl<sub>1:0</sub></i>	<i>FlagW<sub>1:0</sub></i>	<i>Shift</i>
0	X	X	Not DP	00	00	0
1	0100	0	ADD	00	00	0
		1			11	0
	0010	0	SUB	01	00	0
		1			11	0
	0000	0	AND	10	00	0
		1			10	0
	1100	0	ORR	11	00	0
		1			10	0
1101	0	ASR	XX	00	1	
	1	ASR	XX	10	1	

**Datapath**

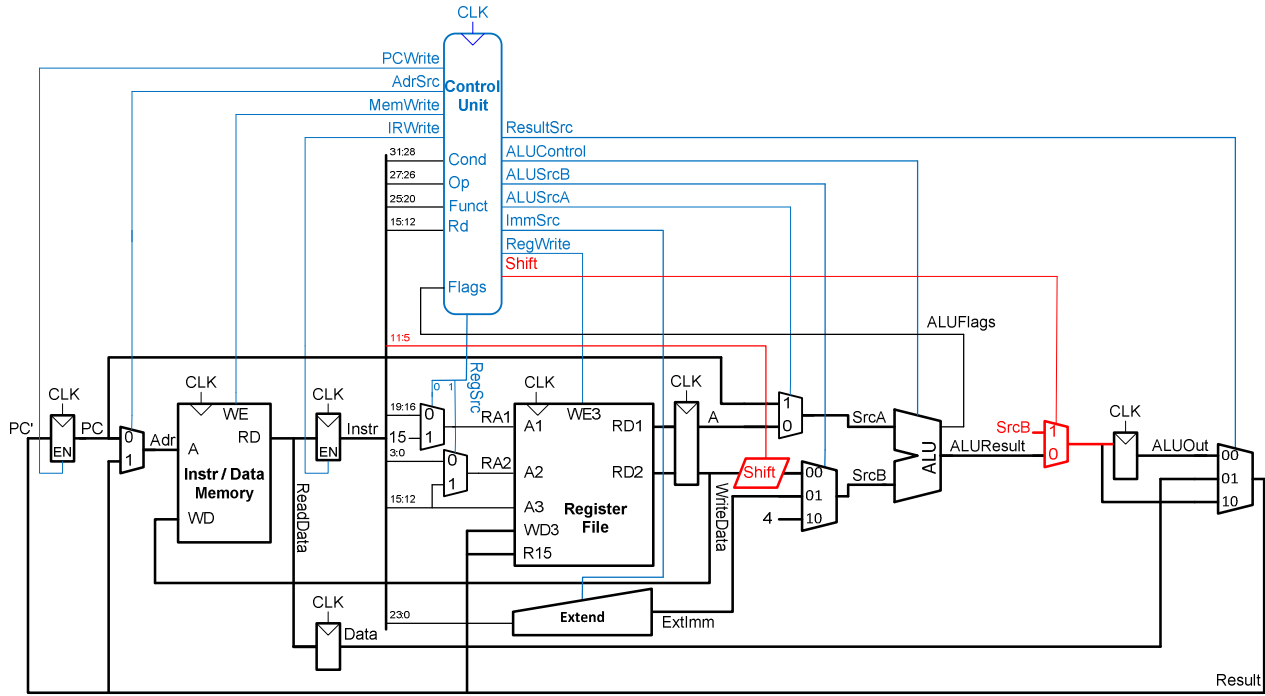

**Control**

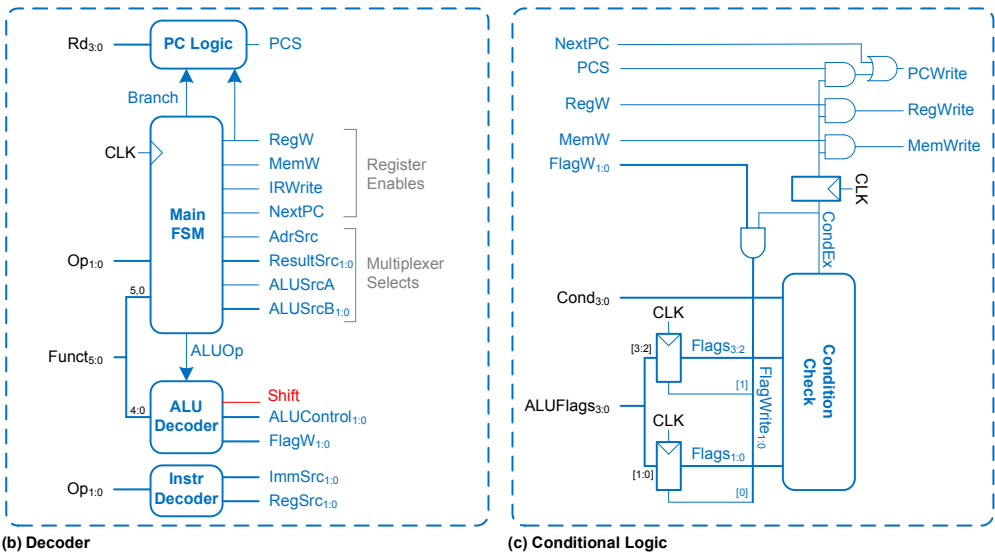
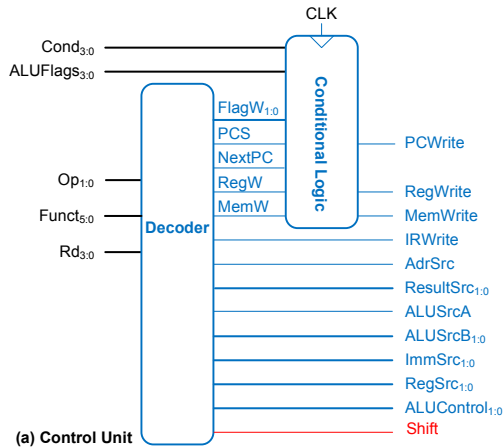

(b) TST

**ALU Decoder truth table**

<i>ALUOp</i>	<i>Funct</i> <sub>4:1</sub> ( <i>cmd</i> )	<i>Funct</i> <sub>0</sub> ( <i>S</i> )	Notes	<i>ALUControl</i> <sub>1:0</sub>	<i>FlagW</i> <sub>1:0</sub>	<i>NoWrite</i>
0	X	X	Not DP	00	00	0
1	0100	0	ADD	00	00	0
		1			11	0
	0010	0	SUB	01	00	0
		1			11	0
	0000	0	AND	10	00	0
		1			10	0
	1100	0	ORR	11	00	0
		1			10	0
1000	1000	1	TST	10	10	1

**Control**

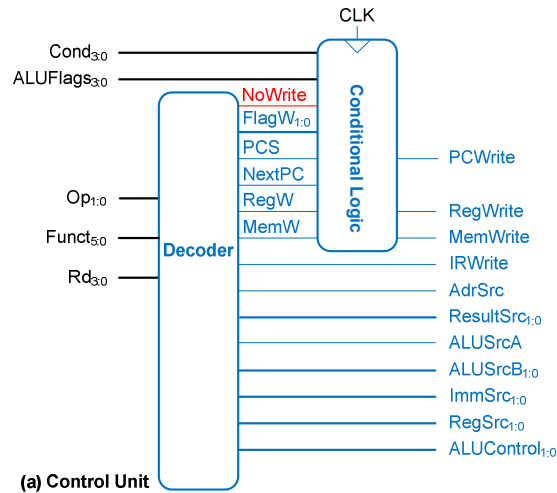

(a) Control Unit

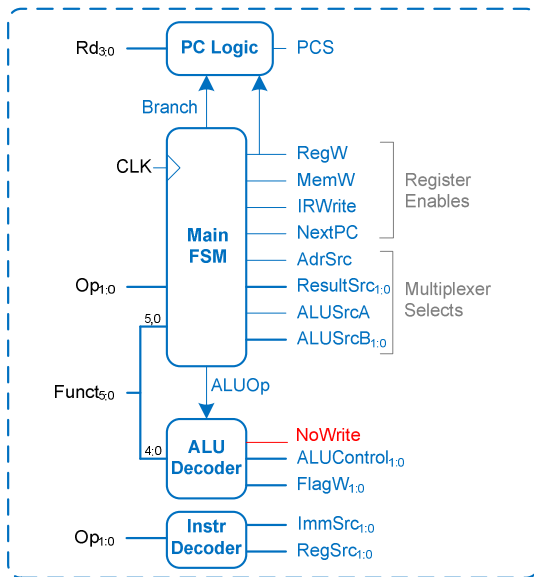

(b) Decoder

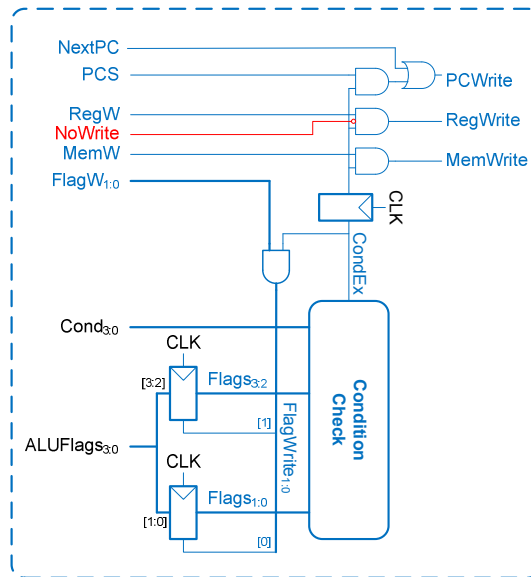

(c) Conditional Logic

(c) SBC

**ALU**





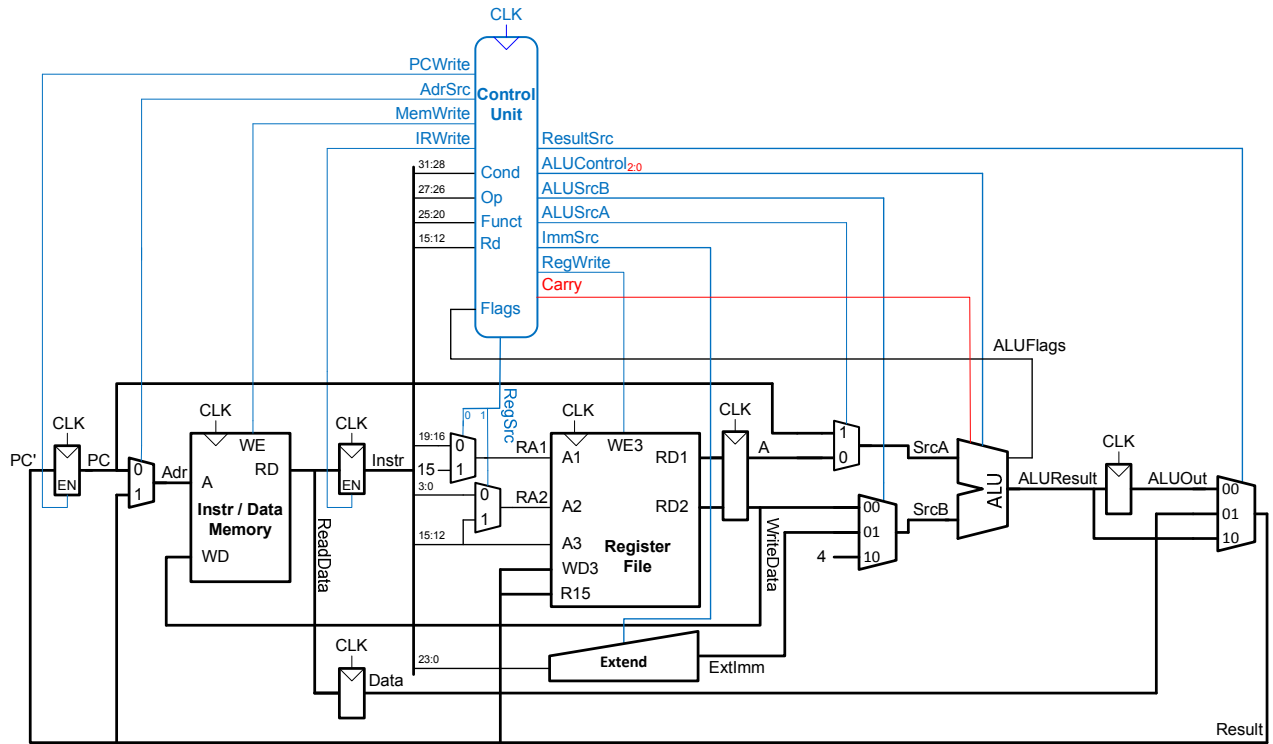

**Control**

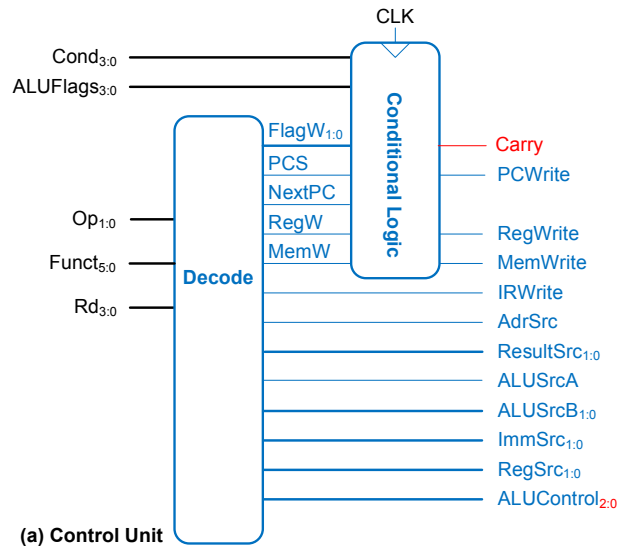

(a) Control Unit

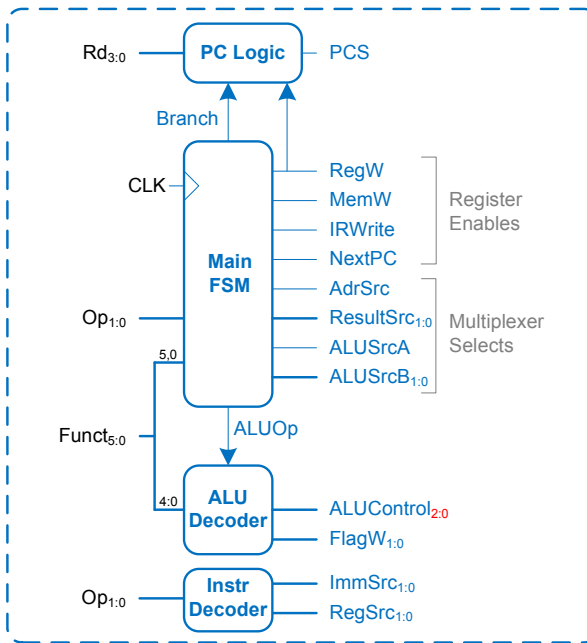

(b) Decode

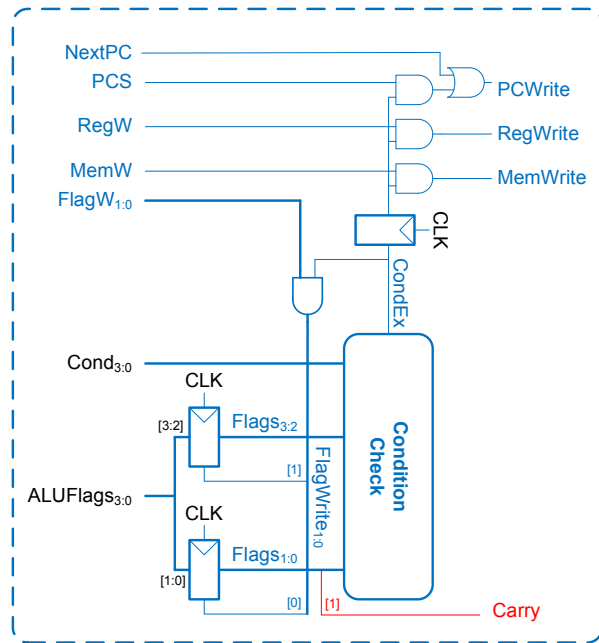

(c) Conditional Logic

(d) ROR

ALU Decoder truth table

ALUOp	Funct <sub>4:1</sub> (cmd)	Funct <sub>0</sub> (S)	Notes	ALUControl <sub>1:0</sub>	FlagW <sub>1:0</sub>	Shift
0	X	X	Not DP	00	00	0
1	0100	0	ADD	00	00	0
		1			11	0
	0010	0	SUB	01	00	0
		1			11	0
	0000	0	AND	10	00	0
		1			10	0
1100	0	ORR	11	00	0	
	1			10	0	
1101	0	ROR	XX	00	00	1
	1			10	10	1

Datapath

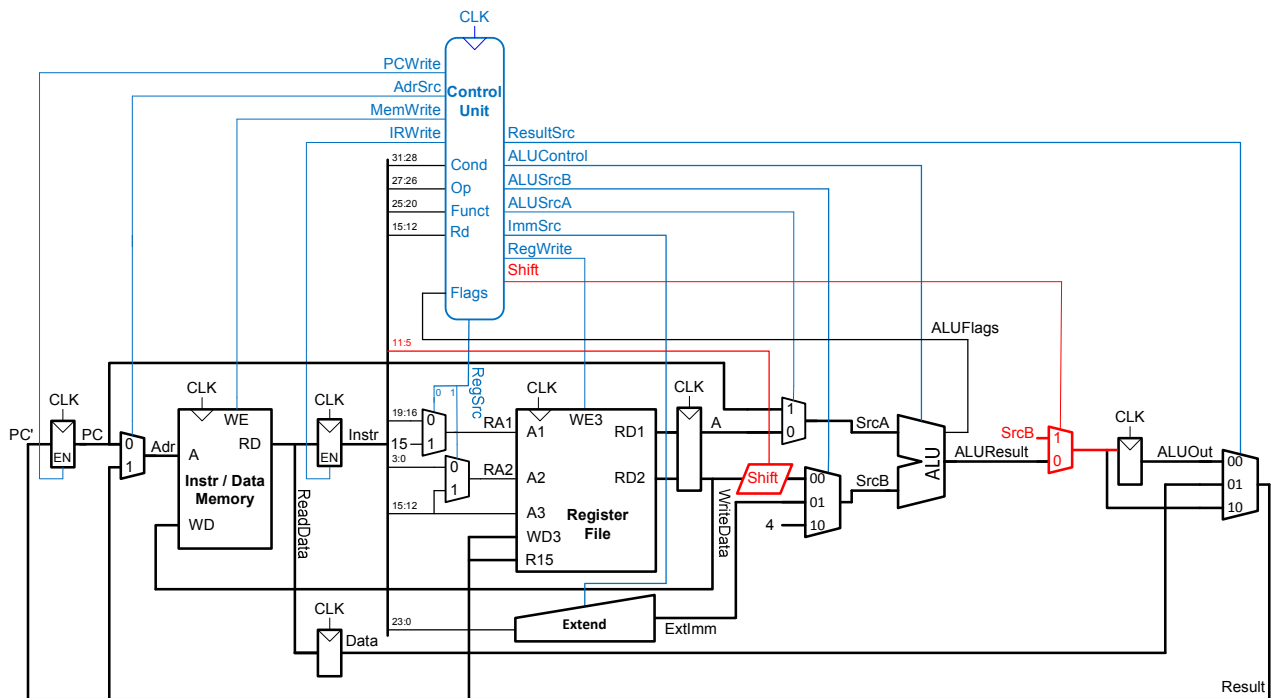

**Exercise 7.15**

Yes, it is possible to add this instruction without modifying the register file. First we show the modifications to the datapath.

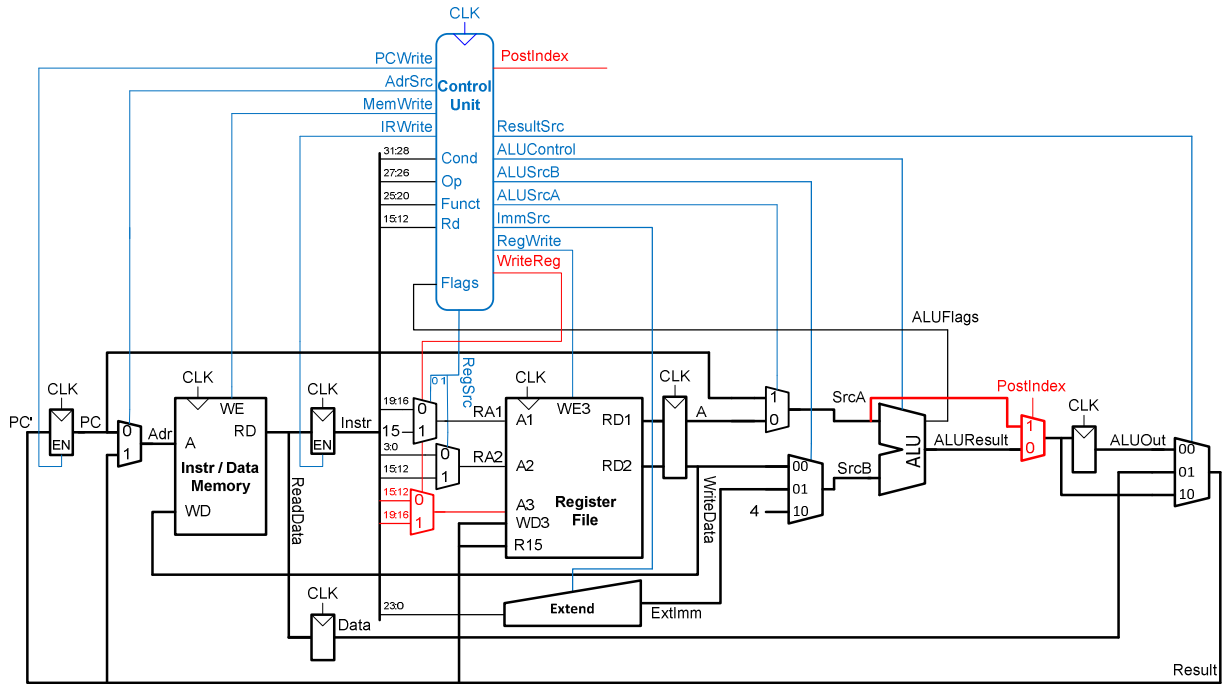

Because two different registers will be written (first Rd with the loaded value, then Rn with  $Rn + Src2$ ), the select signal for the A3 multiplexer (WriteReg) must be an output of the FSM. Here are the control unit schematic and the Main FSM state transition diagram.

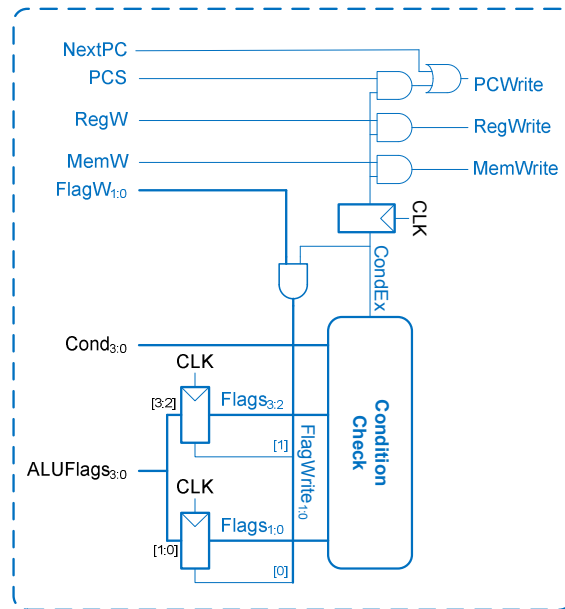
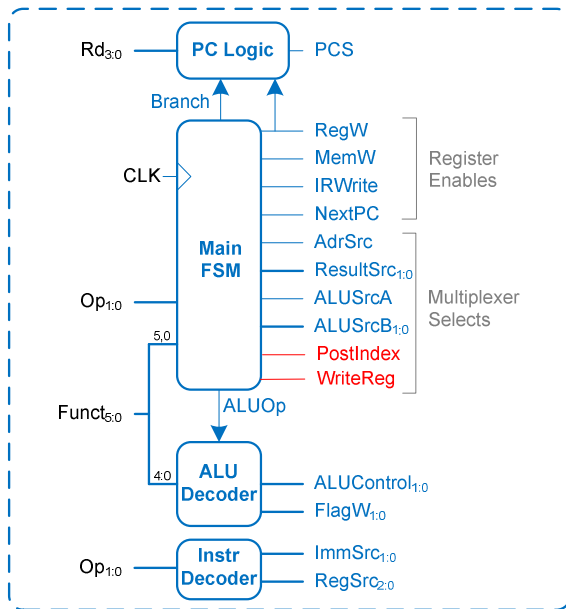
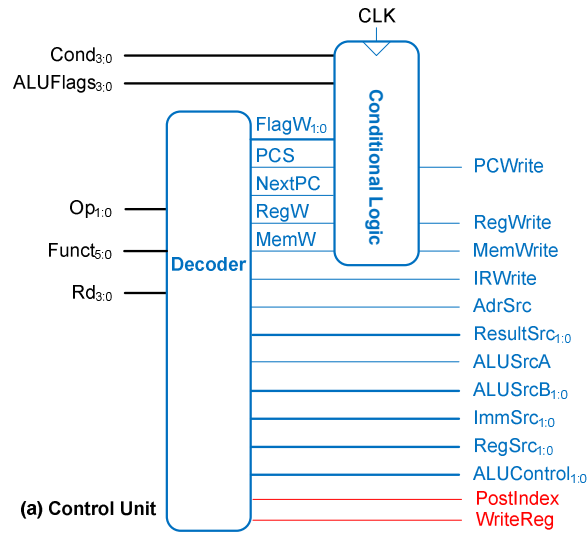

(b) Decoder

(c) Conditional Logic

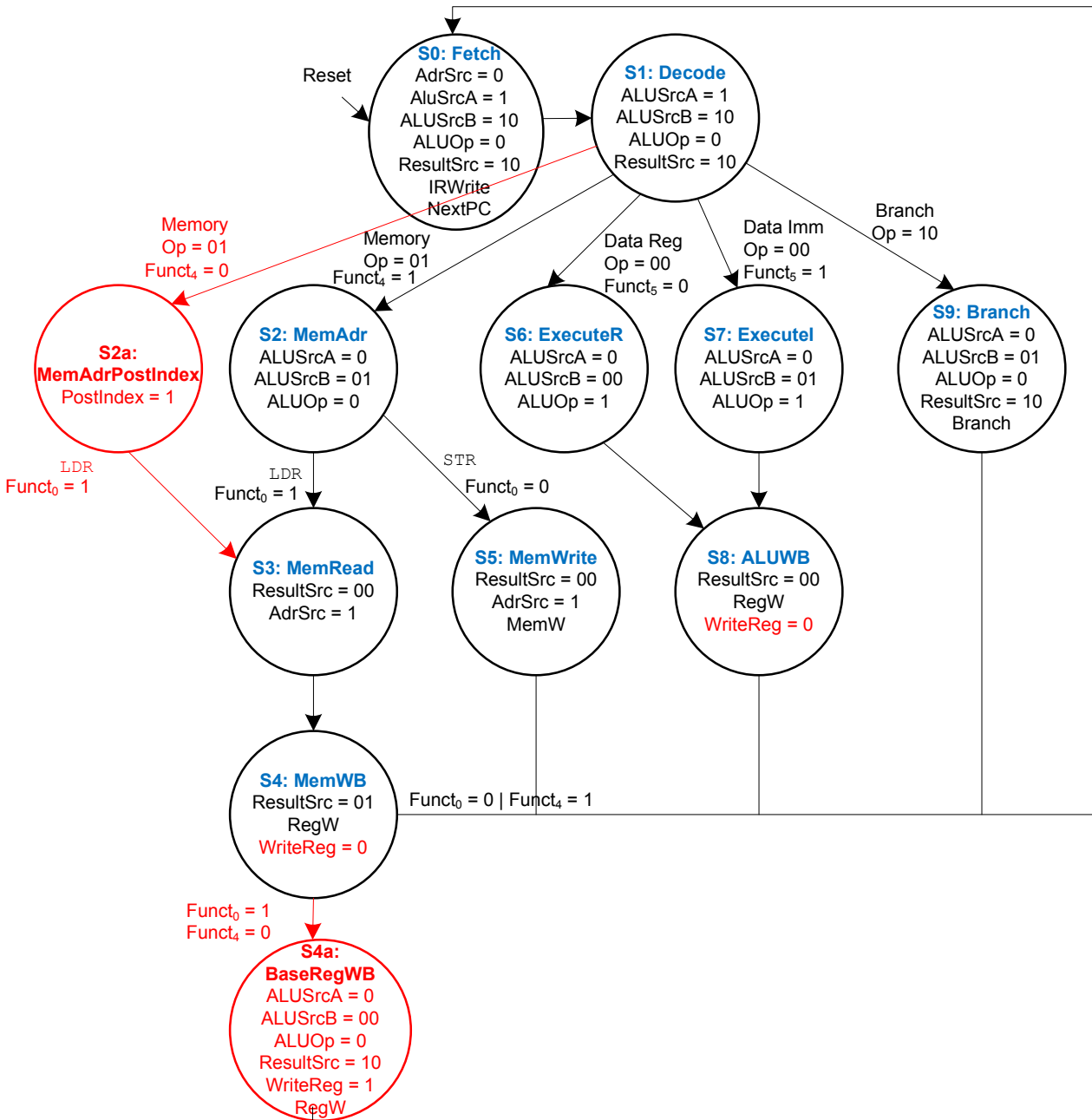

State	Datapath $\mu$ Op
Fetch	Instr $\leftarrow$ Mem[PC]; PC $\leftarrow$ PC+4
Decode	ALUOut $\leftarrow$ PC+4
MemAdr	ALUOut $\leftarrow$ Rn + Imm
MemAdrPostIndex	ALUOut $\leftarrow$ Rn
MemRead	Data $\leftarrow$ Mem[ALUOut]
MemWB	Rd $\leftarrow$ Data
BaseRegWB	Rn $\leftarrow$ Rn + Rm
MemWrite	Mem[ALUOut] $\leftarrow$ Rd
ExecuteR	ALUOut $\leftarrow$ Rn op Rm
ExecuteI	ALUOut $\leftarrow$ Rn op Imm
ALUWB	Rd $\leftarrow$ ALUOut
Branch	PC $\leftarrow$ R15 + offset

Now we modify the **Instr Decoder** logic for  $\text{RegSrc}_{1:0}$  and  $\text{ImmSrc}_{1:0}$  (similar to Table 7.6 in the text).

Instruction	Op	Funct <sub>5:0</sub>	RegSrc <sub>1:0</sub>	ImmSrc <sub>1:0</sub>
LDR (offset indexing, imm offset)	01	011001	X0	01
<b>LDR</b> <b>(post-indexing, reg offset)</b>	<b>01</b>	<b>1010X1</b>	<b>00</b>	<b>XX</b>
STR	01	XXXXXX	10	01
DP imm	00	1XXXXX	X0	00
DP reg	00	0XXXXX	00	00
B	10	XXXXXX	X1	10

### Exercise 7.17

---

From Equation 7.4,  $T_{c2} = t_{pcq} + 2t_{mux} + \max[t_{ALU} + t_{mux}, t_{mem}] + t_{setup}$

She should choose to decrease the delay of the memory.

$$t_{mem} = (200/2) \text{ ps} = 100 \text{ ps}$$

With this new memory delay, the ALU is on the critical path instead of the memory.

$$\begin{aligned} T_{c2} &= [40 + 2(25) + \max[120 + 25, 100] + 50] \text{ ps} \\ &= [40 + 2(25) + 145 + 50] \text{ ps} \\ &= \mathbf{285 \text{ ps}} \end{aligned}$$

### Exercise 7.19

---

She should choose the memory. The new delay should be 145 ps. Making it less than that does not improve performance.

$$t_{mem} = \mathbf{15 \text{ ps}}$$

With this new memory delay, the ALU is on the critical path instead of the memory.

$$\begin{aligned} T_{c2} &= [40 + 2(25) + \max[120 + 25, 145] + 50] \text{ ps} \\ &= [40 + 2(25) + 145 + 50] \text{ ps} \\ &= \mathbf{285 \text{ ps}} \end{aligned}$$

### Exercise 7.21

---

Yes, Alyssa should switch to the slower but lower power register file for her multicycle processor design.



Doubling the delay of the register file does not put it on the critical path. The setup time constraint affected by the register file delay (i.e., between the instruction register and the A and B registers) is:

$$T_c = t_{pcq} + t_{mux} + t_{RRead} + t_{setup}$$

$$= (40 + 25 + 200 + 50) \text{ ps} = \mathbf{315 \text{ ps}}$$

This is still less than the 340 ps of the critical path (see Example 7.6), so increasing the delay of the register file does not affect the cycle time.

### Exercise 7.23

---

The program executes 2 data-processing instructions before the loop. It executes the entire loop 5 times and then executes the `CMP` and `BEQ` only on the sixth iteration, for a total of: 2 DP instructions + 5 (2 DP + 2 Branch) + (1 DP + 1 B) = 13 DP + 11 B. Each data-processing instruction takes 4 cycles and each branch instruction takes 3 cycles, so the total number of cycles required to execute the program is:

$$13(4) + 11(3) = \mathbf{85 \text{ cycles}}$$

### Exercise 7.25

---

#### SystemVerilog

```
// ARM multicycle processor
module testbench();

    logic        clk;
    logic        reset;

    logic [31:0] WriteData, DataAdr;
    logic        MemWrite;

    // instantiate device to be tested
    top dut(clk, reset, WriteData, DataAdr, MemWrite);

    // initialize test
    initial
    begin
        reset <= 1; # 22; reset <= 0;
    end

    // generate clock to sequence tests
    always
    begin
        clk <= 1; # 5; clk <= 0; # 5;
    end

    // check results
    always @(negedge clk)
```

```

begin
  if(MemWrite) begin
    if(DataAdr === 100 & WriteData === 7) begin
      $display("Simulation succeeded");
      $stop;
    end else if (DataAdr !== 96) begin
      $display("Simulation failed");
      $stop;
    end
  end
end
endmodule

module top(input  logic      clk, reset,
           output logic [31:0] WriteData, Adr,
           output logic      MemWrite);

  logic [31:0] ReadData;

  // instantiate processor and shared memory
  arm arm(clk, reset, MemWrite, Adr,
          WriteData, ReadData);
  mem mem(clk, MemWrite, Adr, WriteData, ReadData);
endmodule

module mem(input  logic      clk, we,
           input  logic [31:0] a, wd,
           output logic [31:0] rd);

  logic [31:0] RAM[63:0];

  initial
    $readmemh("memfile.dat",RAM);

  assign rd = RAM[a[31:2]]; // word aligned

  always_ff @(posedge clk)
    if (we) RAM[a[31:2]] <= wd;
endmodule

module arm(input  logic      clk, reset,
           output logic      MemWrite,
           output logic [31:0] Adr, WriteData,
           input  logic [31:0] ReadData);

  logic [31:0] Instr;
  logic [3:0]  ALUFlags;
  logic        PCWrite, RegWrite, IRWrite;
  logic        AdrSrc, ALUSrcA;
  logic [1:0]  RegSrc, ALUSrcB, ImmSrc, ALUControl, ResultSrc;

  controller c(clk, reset, Instr[31:12], ALUFlags,
               PCWrite, MemWrite, RegWrite, IRWrite,

```

```

        AddrSrc, RegSrc, ALUSrcA, ALUSrcB, ResultSrc,
        ImmSrc, ALUControl);
datapath dp(clk, reset, Addr, WriteData, ReadData, Instr, ALUFlags,
PCWrite, RegWrite, IRWrite,
AddrSrc, RegSrc, ALUSrcA, ALUSrcB, ResultSrc,
ImmSrc, ALUControl);
endmodule

module controller(input  logic      clk,
                 input  logic      reset,
                 input  logic [31:12] Instr,
                 input  logic [3:0] ALUFlags,
                 output logic      PCWrite,
                 output logic      MemWrite,
                 output logic      RegWrite,
                 output logic      IRWrite,
                 output logic      AddrSrc,
                 output logic [1:0] RegSrc,
                 output logic      ALUSrcA,
                 output logic [1:0] ALUSrcB,
                 output logic [1:0] ResultSrc,
                 output logic [1:0] ImmSrc,
                 output logic [1:0] ALUControl);

    logic [1:0] FlagW;
    logic      PCS, NextPC, RegW, MemW;

    decoder dec(clk, reset, Instr[27:26], Instr[25:20], Instr[15:12],
FlagW, PCS, NextPC, RegW, MemW,
IRWrite, AddrSrc, ResultSrc,
ALUSrcA, ALUSrcB, ImmSrc, RegSrc, ALUControl);
    condlogic cl(clk, reset, Instr[31:28], ALUFlags,
FlagW, PCS, NextPC, RegW, MemW,
PCWrite, RegWrite, MemWrite);
endmodule

module decoder(input  logic      clk, reset,
              input  logic [1:0] Op,
              input  logic [5:0] Funct,
              input  logic [3:0] Rd,
              output logic [1:0] FlagW,
              output logic      PCS, NextPC, RegW, MemW,
              output logic      IRWrite, AddrSrc,
              output logic [1:0] ResultSrc,
              output logic      ALUSrcA,
              output logic [1:0] ALUSrcB, ImmSrc, RegSrc, ALUControl);

    logic      Branch, ALUOp;

    // Main FSM
    mainfsm fsm(clk, reset, Op, Funct,
IRWrite, AddrSrc,
ALUSrcA, ALUSrcB, ResultSrc,
NextPC, RegW, MemW, Branch, ALUOp);

```

```

always_comb
  if (ALUOp) begin // which Data-processing Instr?
    case(Funct[4:1])
      4'b0100: ALUControl = 2'b00; // ADD
      4'b0010: ALUControl = 2'b01; // SUB
      4'b0000: ALUControl = 2'b10; // AND
      4'b1100: ALUControl = 2'b11; // ORR
      default: ALUControl = 2'bx; // unimplemented
    endcase
    FlagW[1] = Funct[0]; // update N & Z flags if S bit is set
    FlagW[0] = Funct[0] & (ALUControl == 2'b00 | ALUControl ==
2'b01);
  end else begin
    ALUControl = 2'b00; // add for non data-processing instructions
    FlagW = 2'b00; // don't update Flags
  end

// PC Logic
assign PCS = ((Rd == 4'b1111) & RegW) | Branch;

// Instr Decoder
assign ImmSrc = Op;
assign RegSrc[0] = (Op == 2'b10); // read PC on Branch
assign RegSrc[1] = (Op == 2'b01); // read Rd on STR
endmodule

module mainfsm(input logic clk,
               input logic reset,
               input logic [1:0] Op,
               input logic [5:0] Funct,
               output logic IRWrite,
               output logic AdrSrc, ALUSrcA,
               output logic [1:0] ALUSrcB, ResultSrc,
               output logic NextPC, RegW, MemW, Branch, ALUOp);

  typedef enum logic [3:0] {FETCH, DECODE, MEMADR, MEMRD, MEMWB,
                           MEMWR, EXECUTER, EXECUTEI, ALUWB, BRANCH,
                           UNKNOWN}
  statetype;

  statetype state, nextstate;
  logic [11:0] controls;

  // state register
  always @(posedge clk or posedge reset)
    if (reset) state <= FETCH;
    else state <= nextstate;

  // next state logic
  always_comb
    case(state)
      FETCH: nextstate = DECODE;
      DECODE: case(Op)

```

```

                2'b00:
                    if (Funct[5]) nextstate = EXECUTEI;
                    else         nextstate = EXECUTER;
                2'b01:         nextstate = MEMADR;
                2'b10:         nextstate = BRANCH;
                default:       nextstate = UNKNOWN;
            endcase
EXECUTER:         nextstate = ALUWB;
EXECUTEI:        nextstate = ALUWB;
MEMADR:
    if (Funct[0]) nextstate = MEMRD;
    else         nextstate = MEMWR;
MEMRD:          nextstate = MEMWB;
default:        nextstate = FETCH;
endcase

// state-dependent output logic
always_comb
    case (state)
        FETCH:     controls = 12'b10001_010_1100;
        DECODE:    controls = 12'b00000_010_1100;
        EXECUTER:  controls = 12'b00000_000_0001;
        EXECUTEI:  controls = 12'b00000_000_0011;
        ALUWB:     controls = 12'b00010_000_0000;
        MEMADR:    controls = 12'b00000_000_0010;
        MEMWR:     controls = 12'b00100_100_0000;
        MEMRD:     controls = 12'b00000_100_0000;
        MEMWB:     controls = 12'b00010_001_0000;
        BRANCH:    controls = 12'b01000_010_0010;
        default:   controls = 12'bxxxxx_xxx_xxxx;
    endcase

    assign {NextPC, Branch, MemW, RegW, IRWrite,
            AdrSrc, ResultSrc,
            ALUSrcA, ALUSrcB, ALUOp} = controls;
endmodule

module condlogic(input  logic      clk, reset,
                 input  logic [3:0] Cond,
                 input  logic [3:0] ALUFlags,
                 input  logic [1:0] FlagW,
                 input  logic      PCS, NextPC, RegW, MemW,
                 output logic      PCWrite, RegWrite, MemWrite);

    logic [1:0] FlagWrite;
    logic [3:0] Flags;
    logic      CondEx, CondExDelayed;

    flopenr #(2)flagreg1(clk, reset, FlagWrite[1], ALUFlags[3:2],
Flags[3:2]);
    flopenr #(2)flagreg0(clk, reset, FlagWrite[0], ALUFlags[1:0],
Flags[1:0]);

    // write controls are conditional

```

```

condcheck cc(Cond, Flags, CondEx);
floprr #(1)condreg(clk, reset, CondEx, CondExDelayed);
assign FlagWrite = FlagW & {2{CondEx}};
assign RegWrite  = RegW  & CondExDelayed;
assign MemWrite  = MemW  & CondExDelayed;
assign PCWrite   = (PCS  & CondExDelayed) | NextPC;
endmodule

module condcheck(input  logic [3:0] Cond,
                 input  logic [3:0] Flags,
                 output logic      CondEx);

logic neg, zero, carry, overflow, ge;

assign {neg, zero, carry, overflow} = Flags;
assign ge = (neg == overflow);

always_comb
  case(Cond)
    4'b0000: CondEx = zero;           // EQ
    4'b0001: CondEx = ~zero;         // NE
    4'b0010: CondEx = carry;         // CS
    4'b0011: CondEx = ~carry;        // CC
    4'b0100: CondEx = neg;           // MI
    4'b0101: CondEx = ~neg;          // PL
    4'b0110: CondEx = overflow;      // VS
    4'b0111: CondEx = ~overflow;     // VC
    4'b1000: CondEx = carry & ~zero; // HI
    4'b1001: CondEx = ~(carry & ~zero); // LS
    4'b1010: CondEx = ge;            // GE
    4'b1011: CondEx = ~ge;           // LT
    4'b1100: CondEx = ~zero & ge;    // GT
    4'b1101: CondEx = ~(~zero & ge); // LE
    4'b1110: CondEx = 1'b1;         // Always
    default: CondEx = 1'bx;         // undefined
  endcase
endmodule

module datapath(input  logic      clk, reset,
                output logic [31:0] Adr, WriteData,
                input  logic [31:0] ReadData,
                output logic [31:0] Instr,
                output logic [3:0]  ALUFlags,
                input  logic      PCWrite, RegWrite,
                input  logic      IRWrite,
                input  logic      AdrSrc,
                input  logic [1:0] RegSrc,
                input  logic      ALUSrcA,
                input  logic [1:0] ALUSrcB, ResultSrc,
                input  logic [1:0] ImmSrc, ALUControl);

logic [31:0] PCNext, PC;
logic [31:0] ExtImm, SrcA, SrcB, Result;
logic [31:0] Data, RD1, RD2, A, ALUResult, ALUOut;

```

```

logic [3:0] RA1, RA2;

// next PC logic
flopnr #(32) pcreg(clk, reset, PCWrite, Result, PC);

// memory logic
mux2 #(32) adrmux(PC, ALUOut, AdrSrc, Adr);
flopnr #(32) ir(clk, reset, IRWrite, ReadData, Instr);
flopnr #(32) datareg(clk, reset, ReadData, Data);

// register file logic
mux2 #(4) ralmux(Instr[19:16], 4'b1111, RegSrc[0], RA1);
mux2 #(4) ra2mux(Instr[3:0], Instr[15:12], RegSrc[1], RA2);
regfile rf(clk, RegWrite, RA1, RA2,
           Instr[15:12], Result, Result,
           RD1, RD2);
flopnr #(32) srcareg(clk, reset, RD1, A);
flopnr #(32) wdreg(clk, reset, RD2, WriteData);
extend ext(Instr[23:0], ImmSrc, ExtImm);

// ALU logic
mux2 #(32) srcamux(A, PC, ALUSrcA, SrcA);
mux3 #(32) srcbmux(WriteData, ExtImm, 32'd4, ALUSrcB, SrcB);
alu alu(SrcA, SrcB, ALUControl, ALUResult, ALUFlags);
flopnr #(32) aluoutreg(clk, reset, ALUResult, ALUOut);
mux3 #(32) resmux(ALUOut, Data, ALUResult, ResultSrc, Result);
endmodule

module regfile(input logic clk,
              input logic we3,
              input logic [3:0] ra1, ra2, wa3,
              input logic [31:0] wd3, r15,
              output logic [31:0] rd1, rd2);

logic [31:0] rf[14:0];

// three ported register file
// read two ports combinationally
// write third port on rising edge of clock
// register 15 reads PC+8 instead

always_ff @(posedge clk)
  if (we3) rf[wa3] <= wd3;

assign rd1 = (ra1 == 4'b1111) ? r15 : rf[ra1];
assign rd2 = (ra2 == 4'b1111) ? r15 : rf[ra2];
endmodule

module extend(input logic [23:0] Instr,
             input logic [1:0] ImmSrc,
             output logic [31:0] ExtImm);

always_comb
  case(ImmSrc)

```

```

        // 8-bit unsigned immediate
2'b00: ExtImm = {24'b0, Instr[7:0]};
        // 12-bit unsigned immediate
2'b01: ExtImm = {20'b0, Instr[11:0]};
        // 24-bit two's complement shifted branch
2'b10: ExtImm = {{6{Instr[23]}}, Instr[23:0], 2'b00};
        default: ExtImm = 32'bx; // undefined
    endcase
endmodule

module adder #(parameter WIDTH=8)
    (input  logic [WIDTH-1:0] a, b,
     output logic [WIDTH-1:0] y);

    assign y = a + b;
endmodule

module flopenr #(parameter WIDTH = 8)
    (input  logic          clk, reset, en,
     input  logic [WIDTH-1:0] d,
     output logic [WIDTH-1:0] q);

    always_ff @(posedge clk, posedge reset)
        if (reset)    q <= 0;
        else if (en) q <= d;
endmodule

module flopr #(parameter WIDTH = 8)
    (input  logic          clk, reset,
     input  logic [WIDTH-1:0] d,
     output logic [WIDTH-1:0] q);

    always_ff @(posedge clk, posedge reset)
        if (reset) q <= 0;
        else      q <= d;
endmodule

module mux2 #(parameter WIDTH = 8)
    (input  logic [WIDTH-1:0] d0, d1,
     input  logic          s,
     output logic [WIDTH-1:0] y);

    assign y = s ? d1 : d0;
endmodule

module mux3 #(parameter WIDTH = 8)
    (input  logic [WIDTH-1:0] d0, d1, d2,
     input  logic [1:0]      s,
     output logic [WIDTH-1:0] y);

    assign y = s[1] ? d2 : (s[0] ? d1 : d0);
endmodule

module alu(input  logic [31:0] a, b,

```



```

        input  logic [1:0]  ALUControl,
        output logic [31:0] Result,
        output logic [3:0]  ALUFlags);

logic      neg, zero, carry, overflow;
logic [31:0] condinvb;
logic [32:0] sum;

assign condinvb = ALUControl[0] ? ~b : b;
assign sum = a + condinvb + ALUControl[0];

always_comb
    casex (ALUControl[1:0])
        2'b0?: Result = sum;
        2'b10: Result = a & b;
        2'b11: Result = a | b;
    endcase

assign neg      = Result[31];
assign zero     = (Result == 32'b0);
assign carry    = (ALUControl[1] == 1'b0) & sum[32];
assign overflow = (ALUControl[1] == 1'b0) & ~(a[31] ^ b[31] ^
        ALUControl[0]) & (a[31] ^ sum[31]);
assign ALUFlags = {neg, zero, carry, overflow};
endmodule

```

**VHDL**

```

library IEEE;
use IEEE.STD_LOGIC_1164.all; use IEEE.NUMERIC_STD_UNSIGNED.all;
entity testbench is
end;

architecture test of testbench is
    component top
        port (clk, reset:          in  STD_LOGIC;
              WriteData, Adr:      out STD_LOGIC_VECTOR(31 downto 0);
              MemWrite:           out STD_LOGIC);
    end component;
    signal WriteData, DataAdr:      STD_LOGIC_VECTOR(31 downto 0);
    signal clk, reset, MemWrite:   STD_LOGIC;
begin

    -- instantiate device to be tested
    dut: top port map (clk, reset, WriteData, DataAdr, MemWrite);

    -- Generate clock with 10 ns period
    process begin
        clk <= '1';
        wait for 5 ns;
        clk <= '0';
        wait for 5 ns;
    end process;

```

```

-- Generate reset for first two clock cycles
process begin
  reset <= '1';
  wait for 22 ns;
  reset <= '0';
  wait;
end process;

-- check that 7 gets written to address 84
-- at end of program
process (clk) begin
  if (clk'event and clk = '0' and MemWrite = '1') then
    if (to_integer(DataAdr) = 100 and
        to_integer(WriteData) = 7) then
      report "NO ERRORS: Simulation succeeded" severity failure;
    elsif (DataAdr /= 96) then
      report "Simulation failed" severity failure;
    end if;
  end if;
end process;
end;

library IEEE;
use IEEE.STD_LOGIC_1164.all; use IEEE.NUMERIC_STD_UNSIGNED.all;
entity top is -- top-level design for testing
  port (clk, reset:          in    STD_LOGIC;
        WriteData, Adr:     buffer STD_LOGIC_VECTOR(31 downto 0);
        MemWrite:           buffer STD_LOGIC);
end;

architecture test of top is
  component arm
    port (clk, reset:        in    STD_LOGIC;
          MemWrite:         out   STD_LOGIC;
          Adr, WriteData:   out   STD_LOGIC_VECTOR(31 downto 0);
          ReadData:        in    STD_LOGIC_VECTOR(31 downto 0));
  end component;
  component mem
    port (clk, we:          in    STD_LOGIC;
          a, wd:           in    STD_LOGIC_VECTOR(31 downto 0);
          rd:              out   STD_LOGIC_VECTOR(31 downto 0));
  end component;
  signal ReadData: STD_LOGIC_VECTOR(31 downto 0);
begin
  -- instantiate processor and memories
  i_arm: arm port map (clk, reset, MemWrite, Adr,
                     WriteData, ReadData);
  i_mem: mem port map (clk, MemWrite, Adr,
                     WriteData, ReadData);
end;

library IEEE;
use IEEE.STD_LOGIC_1164.all; use STD.TEXTIO.all;

```

```

use IEEE.NUMERIC_STD_UNSIGNED.all;
entity mem is -- memory
  port(clk, we:  in STD_LOGIC;
        a, wd:   in STD_LOGIC_VECTOR(31 downto 0);
        rd:     out STD_LOGIC_VECTOR(31 downto 0));
end;

architecture behave of mem is -- instruction and data memory
begin
  process is
    file mem_file: TEXT;
    variable L: line;
    variable ch: character;
    variable i, index, result: integer;

    type ramtype is array (63 downto 0) of
      STD_LOGIC_VECTOR(31 downto 0);
    variable ram: ramtype;
  begin
    -- initialize memory from file
    for i in 0 to 63 loop -- set all contents low
      ram(i) := (others => '0');
    end loop;
    index := 0;
    FILE_OPEN(mem_file, "memfile.dat", READ_MODE);
    while not endfile(mem_file) loop
      readline(mem_file, L);
      result := 0;
      for i in 1 to 8 loop
        read(L, ch);
        if '0' <= ch and ch <= '9' then
          result := character'pos(ch) - character'pos('0');
        elsif 'a' <= ch and ch <= 'f' then
          result := character'pos(ch) - character'pos('a')+10;
        elsif 'A' <= ch and ch <= 'F' then
          result := character'pos(ch) - character'pos('A')+10;
        else report "Format error on line " & integer'image(index)
              severity error;
        end if;
        ram(index)(35-i*4 downto 32-i*4) :=
          to_std_logic_vector(result,4);
      end loop;
      index := index + 1;
    end loop;

    -- read or write memory
    loop
      if clk'event and clk = '1' then
        if (we = '1') then
          ram(to_integer(a(7 downto 2))) := wd;
        end if;
      end if;
      rd <= ram(to_integer(a(7 downto 2)));
    end loop;
  end process;
end behave;

```

```

    wait on clk, a;
  end loop;
end process;
end;
```

```

library IEEE; use IEEE.STD_LOGIC_1164.all;
entity arm is -- multicycle processor
  port (clk, reset:      in  STD_LOGIC;
        MemWrite:       out STD_LOGIC;
        Adr, WriteData: out STD_LOGIC_VECTOR(31 downto 0);
        ReadData:       in  STD_LOGIC_VECTOR(31 downto 0));
end;
```

architecture struct of arm is

component controller

```

  port (clk, reset:      in  STD_LOGIC;
        Instr:          in  STD_LOGIC_VECTOR(31 downto 12);
        ALUFlags:       in  STD_LOGIC_VECTOR(3 downto 0);
        PCWrite:       out STD_LOGIC;
        MemWrite:       out STD_LOGIC;
        RegWrite:      out STD_LOGIC;
        IRWrite:       out STD_LOGIC;
        AdrSrc:        out STD_LOGIC;
        RegSrc:        out STD_LOGIC_VECTOR(1 downto 0);
        ALUSrcA:       out STD_LOGIC;
        ALUSrcB:       out STD_LOGIC_VECTOR(1 downto 0);
        ResultSrc:     out STD_LOGIC_VECTOR(1 downto 0);
        ImmSrc:        out STD_LOGIC_VECTOR(1 downto 0);
        ALUControl:    out STD_LOGIC_VECTOR(1 downto 0));
```

end component;

component datapath

```

  port (clk, reset:      in  STD_LOGIC;
        Adr:            out STD_LOGIC_VECTOR(31 downto 0);
        WriteData:     out STD_LOGIC_VECTOR(31 downto 0);
        ReadData:      in  STD_LOGIC_VECTOR(31 downto 0);
        Instr:         out STD_LOGIC_VECTOR(31 downto 0);
        ALUFlags:      out STD_LOGIC_VECTOR(3 downto 0);
        PCWrite:       in  STD_LOGIC;
        RegWrite:      in  STD_LOGIC;
        IRWrite:       in  STD_LOGIC;
        AdrSrc:        in  STD_LOGIC;
        RegSrc:        in  STD_LOGIC_VECTOR(1 downto 0);
        ALUSrcA:       in  STD_LOGIC;
        ALUSrcB:       in  STD_LOGIC_VECTOR(1 downto 0);
        ResultSrc:     in  STD_LOGIC_VECTOR(1 downto 0);
        ImmSrc:        in  STD_LOGIC_VECTOR(1 downto 0);
        ALUControl:    in  STD_LOGIC_VECTOR(1 downto 0));
```

end component;

```

signal Instr: STD_LOGIC_VECTOR(31 downto 0);
signal ALUFlags: STD_LOGIC_VECTOR(3 downto 0);
signal PCWrite, RegWrite, IRWrite: STD_LOGIC;
signal AdrSrc, ALUSrcA: STD_LOGIC;
signal RegSrc, ALUSrcB: STD_LOGIC_VECTOR(1 downto 0);
```

```

    signal ImmSrc, ALUControl, ResultSrc: STD_LOGIC_VECTOR(1 downto 0);

begin
    cont: controller port map(clk, reset, Instr(31 downto 12),
        ALUFlags, PCWrite, MemWrite, RegWrite,
        IRWrite, AdrSrc, RegSrc, ALUSrcA,
        ALUSrcB, ResultSrc, ImmSrc, ALUControl);

    dp: datapath port map(clk, reset, Adr, WriteData, ReadData,
        Instr, ALUFlags,
        PCWrite, RegWrite, IRWrite,
        AdrSrc, RegSrc, ALUSrcA, ALUSrcB, ResultSrc,
        ImmSrc, ALUControl);

end;

library IEEE; use IEEE.STD_LOGIC_1164.all;
entity controller is -- single cycle control decoder
    port(clk, reset:          in  STD_LOGIC;
        Instr:                in  STD_LOGIC_VECTOR(31 downto 12);
        ALUFlags:             in  STD_LOGIC_VECTOR(3 downto 0);
        PCWrite:              out STD_LOGIC;
        MemWrite:             out STD_LOGIC;
        RegWrite:             out STD_LOGIC;
        IRWrite:              out STD_LOGIC;
        AdrSrc:               out STD_LOGIC;
        RegSrc:               out STD_LOGIC_VECTOR(1 downto 0);
        ALUSrcA:              out STD_LOGIC;
        ALUSrcB:              out STD_LOGIC_VECTOR(1 downto 0);
        ResultSrc:           out STD_LOGIC_VECTOR(1 downto 0);
        ImmSrc:               out STD_LOGIC_VECTOR(1 downto 0);
        ALUControl:           out STD_LOGIC_VECTOR(1 downto 0));
end;
architecture struct of controller is
    component decoder
        port(clk, reset:          in  STD_LOGIC;
            Op:                   in  STD_LOGIC_VECTOR(1 downto 0);
            Funct:                in  STD_LOGIC_VECTOR(5 downto 0);
            Rd:                   in  STD_LOGIC_VECTOR(3 downto 0);
            FlagW:                out STD_LOGIC_VECTOR(1 downto 0);
            PCS, NextPC:          out STD_LOGIC;
            RegW, MemW:           out STD_LOGIC;
            IRWrite, AdrSrc:      out STD_LOGIC;
            ResultSrc:           out STD_LOGIC_VECTOR(1 downto 0);
            ALUSrcA:              out STD_LOGIC;
            ALUSrcB, ImmSrc:      out STD_LOGIC_VECTOR(1 downto 0);
            RegSrc:               out STD_LOGIC_VECTOR(1 downto 0);
            ALUControl:           out STD_LOGIC_VECTOR(1 downto 0));
    end component;
    component condlogic
        port(clk, reset:          in  STD_LOGIC;
            Cond:                 in  STD_LOGIC_VECTOR(3 downto 0);
            ALUFlags:             in  STD_LOGIC_VECTOR(3 downto 0);
            FlagW:                in  STD_LOGIC_VECTOR(1 downto 0);

```

```

        PCS, NextPC:      in  STD_LOGIC;
        RegW, MemW:      in  STD_LOGIC;
        PCWrite, RegWrite: out STD_LOGIC;
        MemWrite:       out STD_LOGIC);
    end component;
    signal FlagW: STD_LOGIC_VECTOR(1 downto 0);
    signal PCS, NextPC, RegW, MemW: STD_LOGIC;
begin
    dec: decoder port map(clk, reset, Instr(27 downto 26), Instr(25 downto
20),
                        Instr(15 downto 12), FlagW, PCS,
                        NextPC, RegW, MemW,
                        IRWrite, AdrSrc, ResultSrc,
                        ALUSrcA, ALUSrcB, ImmSrc, RegSrc, ALUControl);
    cl: condlogic port map(clk, reset, Instr(31 downto 28),
                        ALUFlags, FlagW, PCS, NextPC, RegW, MemW,
                        PCWrite, RegWrite, MemWrite);
end;

library IEEE; use IEEE.STD_LOGIC_1164.all;
entity decoder is -- main control decoder
    port(clk, reset:      in  STD_LOGIC;
        Op:              in  STD_LOGIC_VECTOR(1 downto 0);
        Funct:          in  STD_LOGIC_VECTOR(5 downto 0);
        Rd:             in  STD_LOGIC_VECTOR(3 downto 0);
        FlagW:         out STD_LOGIC_VECTOR(1 downto 0);
        PCS, NextPC:   out STD_LOGIC;
        RegW, MemW:    out STD_LOGIC;
        IRWrite, AdrSrc: out STD_LOGIC;
        ResultSrc:    out STD_LOGIC_VECTOR(1 downto 0);
        ALUSrcA:      out STD_LOGIC;
        ALUSrcB, ImmSrc: out STD_LOGIC_VECTOR(1 downto 0);
        RegSrc:      out STD_LOGIC_VECTOR(1 downto 0);
        ALUControl:  out STD_LOGIC_VECTOR(1 downto 0));
end;

architecture behave of decoder is
    component mainfsm
        port(clk, reset:      in  STD_LOGIC;
            Op:              in  STD_LOGIC_VECTOR(1 downto 0);
            Funct:          in  STD_LOGIC_VECTOR(5 downto 0);
            IRWrite:       out STD_LOGIC;
            AdrSrc, ALUSrcA: out STD_LOGIC;
            ALUSrcB:      out STD_LOGIC_VECTOR(1 downto 0);
            ResultSrc:    out STD_LOGIC_VECTOR(1 downto 0);
            NextPC, RegW:  out STD_LOGIC;
            MemW, Branch:  out STD_LOGIC;
            ALUOp:        out STD_LOGIC);
    end component;
    signal Branch, ALUOp: STD_LOGIC;
begin
    -- Main FSM
    fsm: mainfsm port map(clk, reset, Op, Funct,
                        IRWrite, AdrSrc,

```

```

        ALUSrcA, ALUSrcB, ResultSrc,
        NextPC, RegW, MemW, Branch, ALUOp);

process(all) begin -- ALU Decoder
    if (ALUOp) then
        case Funct(4 downto 1) is
            when "0100" => ALUControl <= "00"; -- ADD
            when "0010" => ALUControl <= "01"; -- SUB
            when "0000" => ALUControl <= "10"; -- AND
            when "1100" => ALUControl <= "11"; -- ORR
            when others => ALUControl <= "--"; -- unimplemented
        end case;
        FlagW(1) <= Funct(0);
        FlagW(0) <= Funct(0) and (not ALUControl(1));
    else
        ALUControl <= "00";
        FlagW <= "00";
    end if;
end process;

-- PC Logic
PCS <= ((and Rd) and RegW) or Branch;

-- Instr Decoder
ImmSrc <= Op;
RegSrc(0) <= '1' when (Op = 2B"10") else '0';
RegSrc(1) <= '1' when (Op = 2B"01") else '0';
end;

library IEEE; use IEEE.STD_LOGIC_1164.all;
entity mainfsm is
    port (clk, reset:      in  STD_LOGIC;
          Op:              in  STD_LOGIC_VECTOR(1 downto 0);
          Funct:           in  STD_LOGIC_VECTOR(5 downto 0);
          IRWrite:         out STD_LOGIC;
          AdrSrc, ALUSrcA: out STD_LOGIC;
          ALUSrcB:         out STD_LOGIC_VECTOR(1 downto 0);
          ResultSrc:       out STD_LOGIC_VECTOR(1 downto 0);
          NextPC, RegW:    out STD_LOGIC;
          MemW, Branch:    out STD_LOGIC;
          ALUOp:           out STD_LOGIC);
end;

architecture synth of mainfsm is
    type statetype is (FETCH, DECODE, MEMADR, MEMRD, MEMWB, MEMWR,
                      EXECUTER, EXECUTEI, ALUWB, BR, UNKNOWN);
    signal state, nextstate: statetype;
    signal controls: STD_LOGIC_VECTOR(11 downto 0);
begin
    --state register
    process(clk, reset) begin
        if reset then state <= FETCH;
        elsif rising_edge(clk) then

```

```

        state <= nextstate;
    end if;
end process;

-- next state logic
process(all) begin
    case state is
        when FETCH =>          nextstate <= DECODE;
        when DECODE =>
            case Op is
                when "00" =>    nextstate <= ExecuteI when (Funct(5) = '1')
                                else EXECUTER;
                when "01" =>    nextstate <= MEMADR;
                when "10" =>    nextstate <= BR;
                when others =>  nextstate <= UNKNOWN;
            end case;
        when EXECUTER =>      nextstate <= ALUWB;
        when EXECUTEI =>      nextstate <= ALUWB;
        when MEMADR  =>      nextstate <= MEMRD when (Funct(0) = '1')
                                else MEMWR;
        when MEMRD   =>      nextstate <= MEMWB;
        when others  =>      nextstate <= FETCH;
    end case;
end process;

-- state-dependent output logic
process(all) begin
    case state is
        when FETCH =>    controls <= 12B"100010101100";
        when DECODE =>  controls <= 12B"000000101100";
        when EXECUTER => controls <= 12B"000000000001";
        when EXECUTEI => controls <= 12B"000000000011";
        when ALUWB =>   controls <= 12B"000100000000";
        when MEMADR =>  controls <= 12B"000000000010";
        when MEMWR =>   controls <= 12B"001001000000";
        when MEMRD =>   controls <= 12B"000001000000";
        when MEMWB =>   controls <= 12B"000100010000";
        when BR =>      controls <= 12B"010000100010";
        when others =>  controls <= "XXXXXXXXXXXX";
    end case;
end process;

    (NextPC, Branch, MemW, RegW, IRWrite,
     AdrSrc, ResultSrc,
     ALUSrcA, ALUSrcB, ALUOp) <= controls;
end;

library IEEE; use IEEE.STD_LOGIC_1164.all;
entity condlogic is -- Conditional logic
    port (clk, reset:          in  STD_LOGIC;
          Cond:                in  STD_LOGIC_VECTOR(3 downto 0);
          ALUFlags:            in  STD_LOGIC_VECTOR(3 downto 0);
          FlagW:               in  STD_LOGIC_VECTOR(1 downto 0);
          PCS, NextPC:         in  STD_LOGIC;

```



```

        RegW, MemW:          in  STD_LOGIC;
        PCWrite, RegWrite:  out STD_LOGIC;
        MemWrite:           out STD_LOGIC);
end;

architecture behave of condlogic is
    component condcheck
        port(Cond:          in  STD_LOGIC_VECTOR(3 downto 0);
             Flags:        in  STD_LOGIC_VECTOR(3 downto 0);
             CondEx:       out STD_LOGIC);
    end component;
    component flopenr generic(width: integer);
        port(clk, reset, en: in  STD_LOGIC;
             d:           in  STD_LOGIC_VECTOR(width-1 downto 0);
             q:           out STD_LOGIC_VECTOR(width-1 downto 0));
    end component;
    component flopr generic(width: integer);
        port(clk, reset: in  STD_LOGIC;
             d:           in  STD_LOGIC_VECTOR(width-1 downto 0);
             q:           out STD_LOGIC_VECTOR(width-1 downto 0));
    end component;

    signal FlagWrite:      STD_LOGIC_VECTOR(1 downto 0);
    signal Flags:          STD_LOGIC_VECTOR(3 downto 0);
    signal CondEx:         STD_LOGIC_VECTOR(0 downto 0);
    signal CondExDelayed: STD_LOGIC_VECTOR(0 downto 0);
begin
    flagreg1: flopenr generic map(2)
        port map(clk, reset, FlagWrite(1),
                ALUFlags(3 downto 2), Flags(3 downto 2));
    flagreg0: flopenr generic map(2)
        port map(clk, reset, FlagWrite(0),
                ALUFlags(1 downto 0), Flags(1 downto 0));
    cc: condcheck port map(Cond, Flags, CondEx(0));
    condreg: flopr generic map(1)
        port map(clk, reset, CondEx, CondExDelayed);

    FlagWrite <= FlagW and (CondEx(0), CondEx(0));
    RegWrite  <= RegW  and CondExDelayed(0);
    MemWrite  <= MemW  and CondExDelayed(0);
    PCWrite   <= (PCS  and CondExDelayed(0)) or NextPC;
end;

library IEEE; use IEEE.STD_LOGIC_1164.all;
entity condcheck is
    port(Cond:          in  STD_LOGIC_VECTOR(3 downto 0);
         Flags:        in  STD_LOGIC_VECTOR(3 downto 0);
         CondEx:       out STD_LOGIC);
end;

architecture behave of condcheck is
    signal neg, zero, carry, overflow, ge: STD_LOGIC;
begin

```

```

(neg, zero, carry, overflow) <= Flags;
ge <= (neg xnor overflow);

process(all) begin -- Condition checking
  case Cond is
    when "0000" => CondEx <= zero;
    when "0001" => CondEx <= not zero;
    when "0010" => CondEx <= carry;
    when "0011" => CondEx <= not carry;
    when "0100" => CondEx <= neg;
    when "0101" => CondEx <= not neg;
    when "0110" => CondEx <= overflow;
    when "0111" => CondEx <= not overflow;
    when "1000" => CondEx <= carry and (not zero);
    when "1001" => CondEx <= not(carry and (not zero));
    when "1010" => CondEx <= ge;
    when "1011" => CondEx <= not ge;
    when "1100" => CondEx <= (not zero) and ge;
    when "1101" => CondEx <= not ((not zero) and ge);
    when "1110" => CondEx <= '1';
    when others => CondEx <= '-';
  end case;
end process;
end;

library IEEE; use IEEE.STD_LOGIC_1164.all;
entity datapath is
  port (clk, reset:          in  STD_LOGIC;
        Adr:                out  STD_LOGIC_VECTOR(31 downto 0);
        WriteData:          out  STD_LOGIC_VECTOR(31 downto 0);
        ReadData:           in   STD_LOGIC_VECTOR(31 downto 0);
        Instr:              out  STD_LOGIC_VECTOR(31 downto 0);
        ALUFlags:           out  STD_LOGIC_VECTOR(3 downto 0);
        PCWrite:            in   STD_LOGIC;
        RegWrite:           in   STD_LOGIC;
        IRWrite:            in   STD_LOGIC;
        AdrSrc:             in   STD_LOGIC;
        RegSrc:             in   STD_LOGIC_VECTOR(1 downto 0);
        ALUSrcA:            in   STD_LOGIC;
        ALUSrcB:            in   STD_LOGIC_VECTOR(1 downto 0);
        ResultSrc:          in   STD_LOGIC_VECTOR(1 downto 0);
        ImmSrc:             in   STD_LOGIC_VECTOR(1 downto 0);
        ALUControl:         in   STD_LOGIC_VECTOR(1 downto 0));
end;

architecture struct of datapath is
  component alu
    port (a, b:              in   STD_LOGIC_VECTOR(31 downto 0);
          ALUControl:        in   STD_LOGIC_VECTOR(1 downto 0);
          Result:            buffer STD_LOGIC_VECTOR(31 downto 0);
          ALUFlags:          out  STD_LOGIC_VECTOR(3 downto 0));
  end component;
  component regfile
    port (clk:              in   STD_LOGIC;

```

```

        we3:          in  STD_LOGIC;
        ra1, ra2, wa3: in  STD_LOGIC_VECTOR(3 downto 0);
        wd3, r15:    in  STD_LOGIC_VECTOR(31 downto 0);
        rd1, rd2:    out STD_LOGIC_VECTOR(31 downto 0));
end component;
component adder
  port(a, b: in  STD_LOGIC_VECTOR(31 downto 0);
        y:  out STD_LOGIC_VECTOR(31 downto 0));
end component;
component extend
  port(Instr: in  STD_LOGIC_VECTOR(23 downto 0);
        ImmSrc: in STD_LOGIC_VECTOR(1 downto 0);
        ExtImm: out STD_LOGIC_VECTOR(31 downto 0));
end component;
component flopenr generic(width: integer);
  port(clk, reset, en: in  STD_LOGIC;
        d:          in  STD_LOGIC_VECTOR(width-1 downto 0);
        q:          out STD_LOGIC_VECTOR(width-1 downto 0));
end component;
component flopr generic(width: integer);
  port(clk, reset: in  STD_LOGIC;
        d:          in  STD_LOGIC_VECTOR(width-1 downto 0);
        q:          out STD_LOGIC_VECTOR(width-1 downto 0));
end component;
component mux2 generic(width: integer);
  port(d0, d1: in  STD_LOGIC_VECTOR(width-1 downto 0);
        s:      in  STD_LOGIC;
        y:      out STD_LOGIC_VECTOR(width-1 downto 0));
end component;
component mux3 generic(width: integer);
  port(d0, d1, d2: in  STD_LOGIC_VECTOR(width-1 downto 0);
        s:          in  STD_LOGIC_VECTOR(1 downto 0);
        y:          out STD_LOGIC_VECTOR(width-1 downto 0));
end component;
signal PCNext, PC: STD_LOGIC_VECTOR(31 downto 0);
signal ExtImm, SrcA, SrcB: STD_LOGIC_VECTOR(31 downto 0);
signal Result: STD_LOGIC_VECTOR(31 downto 0);
signal Data, RD1, RD2, A: STD_LOGIC_VECTOR(31 downto 0);
signal ALUResult, ALUOut: STD_LOGIC_VECTOR(31 downto 0);
signal RA1, RA2: STD_LOGIC_VECTOR(3 downto 0);
begin
  -- next PC logic
  pcreg: flopenr generic map(32)
    port map(clk, reset, PCWrite, Result, PC);

  -- memory logic
  adrmux: mux2 generic map(32)
    port map(PC, ALUOut, AdrSrc, Adr);
  ir: flopenr generic map(32)
    port map(clk, reset, IRWrite, ReadData, Instr);
  datareg: flopr generic map(32)
    port map(clk, reset, ReadData, Data);

  -- register file logic
  ralmux: mux2 generic map (4)

```

```

    port map(Instr(19 downto 16), "1111", RegSrc(0), RA1);
ra2mux: mux2 generic map (4) port map(Instr(3 downto 0),
    Instr(15 downto 12), RegSrc(1), RA2);
rf: regfile port map(clk, RegWrite, RA1, RA2,
    Instr(15 downto 12), Result, Result,
    RD1, RD2);
srcareg: flopr generic map(32)
    port map(clk, reset, RD1, A);
wdreg: flopr generic map(32)
    port map(clk, reset, RD2, WriteData);
ext: extend port map(Instr(23 downto 0), ImmSrc, ExtImm);

-- ALU logic
srcamux: mux2 generic map(32)
    port map(A, PC, ALUSrcA, SrcA);
srcbmux: mux3 generic map(32)
    port map(WriteData, ExtImm, 32D"4", ALUSrcB, SrcB);
i_alu: alu port map(SrcA, SrcB, ALUControl, ALUResult, ALUFlags);
aluoutreg: flopr generic map(32)
    port map(clk, reset, ALUResult, ALUOut);
resmux: mux3 generic map(32)
    port map(ALUOut, Data, ALUResult, ResultSrc, Result);
end;

library IEEE; use IEEE.STD_LOGIC_1164.all;
use IEEE.NUMERIC_STD_UNSIGNED.all;
entity regfile is -- three-port register file
    port(clk:          in  STD_LOGIC;
         we3:          in  STD_LOGIC;
         ra1, ra2, wa3: in  STD_LOGIC_VECTOR(3 downto 0);
         wd3, r15:     in  STD_LOGIC_VECTOR(31 downto 0);
         rd1, rd2:     out STD_LOGIC_VECTOR(31 downto 0));
end;

architecture behave of regfile is
    type ramtype is array (31 downto 0) of
        STD_LOGIC_VECTOR(31 downto 0);
    signal mem: ramtype;
begin
    process(clk) begin
        if rising_edge(clk) then
            if we3 = '1' then mem(to_integer(wa3)) <= wd3;
            end if;
        end if;
    end process;
    process(all) begin
        if (to_integer(ra1) = 15) then rd1 <= r15;
        else rd1 <= mem(to_integer(ra1));
        end if;
        if (to_integer(ra2) = 15) then rd2 <= r15;
        else rd2 <= mem(to_integer(ra2));
        end if;
    end process;
end;

```

```

library IEEE; use IEEE.STD_LOGIC_1164.all;
use IEEE.NUMERIC_STD_UNSIGNED.all;
entity adder is -- adder
  port(a, b: in  STD_LOGIC_VECTOR(31 downto 0);
        y:      out STD_LOGIC_VECTOR(31 downto 0));
end;

architecture behave of adder is
begin
  y <= a + b;
end;

library IEEE; use IEEE.STD_LOGIC_1164.all;
entity extend is
  port(Instr: in  STD_LOGIC_VECTOR(23 downto 0);
        ImmSrc: in  STD_LOGIC_VECTOR(1 downto 0);
        ExtImm: out STD_LOGIC_VECTOR(31 downto 0));
end;

architecture behave of extend is
begin
  process(all) begin
    case ImmSrc is
      when "00" => ExtImm <= (X"000000", Instr(7 downto 0));
      when "01" => ExtImm <= (X"00000", Instr(11 downto 0));
      when "10" => ExtImm <= (Instr(23), Instr(23), Instr(23),
        Instr(23), Instr(23), Instr(23), Instr(23 downto 0), "00");
      when others => ExtImm <= X"-----";
    end case;
  end process;
end;

library IEEE; use IEEE.STD_LOGIC_1164.all;
entity flopenr is -- flip-flop with enable and asynchronous reset
  generic(width: integer);
  port(clk, reset, en: in  STD_LOGIC;
        d:      in  STD_LOGIC_VECTOR(width-1 downto 0);
        q:      out STD_LOGIC_VECTOR(width-1 downto 0));
end;

architecture asynchronous of flopenr is
begin
  process(clk, reset) begin
    if reset then q <= (others => '0');
    elsif rising_edge(clk) then
      if en then
        q <= d;
      end if;
    end if;
  end process;
end;

library IEEE; use IEEE.STD_LOGIC_1164.all;

```

```

entity flopr is -- flip-flop with asynchronous reset
  generic(width: integer);
  port(clk, reset: in STD_LOGIC;
        d:          in  STD_LOGIC_VECTOR(width-1 downto 0);
        q:          out STD_LOGIC_VECTOR(width-1 downto 0));
end;

```

```

architecture asynchronous of flopr is
begin
  process(clk, reset) begin
    if reset then q <= (others => '0');
    elsif rising_edge(clk) then
      q <= d;
    end if;
  end process;
end;

```

```

library IEEE; use IEEE.STD_LOGIC_1164.all;
entity mux2 is -- two-input multiplexer
  generic(width: integer);
  port(d0, d1: in  STD_LOGIC_VECTOR(width-1 downto 0);
        s:      in  STD_LOGIC;
        y:      out STD_LOGIC_VECTOR(width-1 downto 0));
end;

```

```

architecture behave of mux2 is
begin
  y <= d1 when s else d0;
end;

```

```

library IEEE; use IEEE.STD_LOGIC_1164.all;
entity mux3 is -- three-input multiplexer
  generic(width: integer);
  port(d0, d1, d2: in  STD_LOGIC_VECTOR(width-1 downto 0);
        s:          in  STD_LOGIC_VECTOR(1 downto 0);
        y:          out STD_LOGIC_VECTOR(width-1 downto 0));
end;

```

```

architecture behave of mux3 is
begin
  process(all) begin
    case s is
      when "00"   => y <= d0;
      when "01"   => y <= d1;
      when "10"   => y <= d2;
      when others => y <= d0;
    end case;
  end process;
end;

```

```

library IEEE; use IEEE.STD_LOGIC_1164.all;

```

```

use IEEE.NUMERIC_STD_UNSIGNED.all;
entity alu is
  port(a, b:          in  STD_LOGIC_VECTOR(31 downto 0);
       ALUControl: in  STD_LOGIC_VECTOR(1 downto 0);
       Result:       buffer STD_LOGIC_VECTOR(31 downto 0);
       ALUFlags:     out  STD_LOGIC_VECTOR(3 downto 0));
end;

architecture behave of alu is
  signal condinvb: STD_LOGIC_VECTOR(31 downto 0);
  signal sum:      STD_LOGIC_VECTOR(32 downto 0);
  signal neg, zero, carry, overflow: STD_LOGIC;
begin
  condinvb <= not b when ALUControl(0) else b;
  sum <= ('0', a) + ('0', condinvb) + ALUControl(0);

  process(all) begin
    case? ALUControl(1 downto 0) is
      when "0-" => result <= sum(31 downto 0);
      when "10" => result <= a and b;
      when "11" => result <= a or b;
      when others => result <= (others => '-');
    end case?;
  end process;

  neg <= Result(31);
  zero <= '1' when (Result = 0) else '0';
  carry <= (not ALUControl(1)) and sum(32);
  overflow <= (not ALUControl(1)) and
              (not (a(31) xor b(31) xor ALUControl(0))) and
              (a(31) xor sum(31));
  ALUFlags <= (neg, zero, carry, overflow);
end;

```

### Test ARM assembly code

// If successful, it should write the value 7 to address 100

```

MAIN  SUB R0, R15, R15          ; R0 = 0
      ADD R2, R0, #5           ; R2 = 5
      ADD R3, R0, #12          ; R3 = 12
      SUB R7, R3, #9           ; R7 = 3
      ORR R4, R7, R2           ; R4 = 3 OR 5 = 7
      AND R5, R3, R4           ; R5 = 12 AND 7 = 4
      ADD R5, R5, R4           ; R5 = 4 + 7 = 11
      SUBS R8, R5, R7          ; R8 <= 11 - 3 = 8, set Flags
      BEQ END                  ; shouldn't be taken
      SUBS R8, R3, R4          ; R8 = 12 - 7 = 5
      BGE AROUND              ; should be taken
      ADD R5, R0, #0          ; should be skipped
AROUND
      SUBS R8, R7, R2          ; R8 = 3 - 5 = -2, set Flags
      ADDLT R7, R5, #1         ; R7 = 11 + 1 = 12
      SUB R7, R7, R2          ; R7 = 12 - 5 = 7

```

```

        STR R7, [R3, #84]      ; mem[12+84] = 7
        LDR R2, [R0, #96]    ; R2 = mem[96] = 7
        ADD R15, R15, R0     ; PC <- PC + 8 (skips next)
        ADD R2, R0, #14      ; shouldn't happen
        B END                ; always taken
        ADD R2, R0, #13      ; shouldn't happen
        ADD R2, R0, #10      ; shouldn't happen
END     STR R2, [R0, #100]    ; mem[100] = 7

```

### memfile.dat

```

E04F000F
E2802005
E280300C
E2437009
E1874002
E0035004
E0855004
E0558007
0A00000C
E0538004
AA000000
E2805000
E0578002
B2857001
E0477002
E5837054
E5902060
E08FF000
E280200E
EA000001
E280200D
E280200A
E5802064

```

### Exercise 7.27

---

#### SystemVerilog

```

// Multi-cycle implementation of a subset of ARMv4
// Added instructions:
//   ASR, TST, SBC, ROR

module testbench();

    logic        clk;
    logic        reset;

    logic [31:0] WriteData, DataAdr;
    logic        MemWrite;

    // instantiate device to be tested
    top dut(clk, reset, WriteData, DataAdr, MemWrite);

```



```

// initialize test
initial
begin
  reset <= 1; # 22; reset <= 0;
end

// generate clock to sequence tests
always
begin
  clk <= 1; # 5; clk <= 0; # 5;
end

// check results
always @(negedge clk)
begin
  if(MemWrite) begin
    if(DataAdr == 88 & WriteData == 32'h2fffffff) begin
      $display("Simulation succeeded");
      $stop;
    end else begin
      $display("Simulation failed");
      $stop;
    end
  end
end
endmodule

module top(input logic clk, reset,
           output logic [31:0] WriteData, Adr,
           output logic MemWrite);

  logic [31:0] ReadData;

  // instantiate processor and shared memory
  arm arm(clk, reset, MemWrite, Adr,
         WriteData, ReadData);
  mem mem(clk, MemWrite, Adr, WriteData, ReadData);
endmodule

module mem(input logic clk, we,
           input logic [31:0] a, wd,
           output logic [31:0] rd);

  logic [31:0] RAM[63:0];

  initial
    $readmemh("ex7.27_memfile.dat",RAM);

  assign rd = RAM[a[31:2]]; // word aligned

  always_ff @(posedge clk)
    if (we) RAM[a[31:2]] <= wd;

```

```

endmodule

module arm(input logic clk, reset,
           output logic MemWrite,
           output logic [31:0] Adr, WriteData,
           input logic [31:0] ReadData);

    logic [31:0] Instr;
    logic [3:0] ALUFlags;
    logic PCWrite, RegWrite, IRWrite;
    logic AdrSrc, ALUSrcA;
    logic [1:0] RegSrc, ALUSrcB, ImmSrc, ResultSrc;
    logic [2:0] ALUControl; // SBC
    logic carry; // SBC
    logic Shift; // ASR, ROR

    controller c(clk, reset, Instr[31:12], ALUFlags,
                PCWrite, MemWrite, RegWrite, IRWrite,
                AdrSrc, RegSrc, ALUSrcA, ALUSrcB, ResultSrc,
                ImmSrc, ALUControl, carry, Shift);
    datapath dp(clk, reset, Adr, WriteData, ReadData, Instr, ALUFlags,
                PCWrite, RegWrite, IRWrite,
                AdrSrc, RegSrc, ALUSrcA, ALUSrcB, ResultSrc,
                ImmSrc, ALUControl, carry, Shift);
endmodule

module controller(input logic clk,
                 input logic reset,
                 input logic [31:12] Instr,
                 input logic [3:0] ALUFlags,
                 output logic PCWrite,
                 output logic MemWrite,
                 output logic RegWrite,
                 output logic IRWrite,
                 output logic AdrSrc,
                 output logic [1:0] RegSrc,
                 output logic ALUSrcA,
                 output logic [1:0] ALUSrcB,
                 output logic [1:0] ResultSrc,
                 output logic [1:0] ImmSrc,
                 output logic [2:0] ALUControl, // SBC
                 output logic carry, // SBC
                 output logic Shift // ASR, ROR
                );

    logic [1:0] FlagW;
    logic PCS, NextPC, RegW, MemW;
    logic NoWrite; // TST

    decode dec(clk, reset, Instr[27:26], Instr[25:20], Instr[15:12],
               FlagW, PCS, NextPC, RegW, MemW,
               IRWrite, AdrSrc, ResultSrc,
               ALUSrcA, ALUSrcB, ImmSrc, RegSrc, ALUControl,
               NoWrite, // TST

```

```

        Shift); // ASR, ROR
    condlogic cl(clk, reset, Instr[31:28], ALUFlags,
        FlagW, PCS, NextPC, RegW, MemW,
        PCWrite, RegWrite, MemWrite,
        carry, // SBC
        NoWrite); // TST
endmodule

module decode(input logic clk, reset,
    input logic [1:0] Op,
    input logic [5:0] Funct,
    input logic [3:0] Rd,
    output logic [1:0] FlagW,
    output logic PCS, NextPC, RegW, MemW,
    output logic IRWrite, AdrSrc,
    output logic [1:0] ResultSrc,
    output logic ALUSrcA,
    output logic [1:0] ALUSrcB, ImmSrc, RegSrc,
    output logic [2:0] ALUControl, // SBC
    output logic NoWrite, // TST
    output logic Shift); // ASR, ROR

    logic Branch, ALUOp;

    // Main FSM
    mainfsm fsm(clk, reset, Op, Funct,
        IRWrite, AdrSrc,
        ALUSrcA, ALUSrcB, ResultSrc,
        NextPC, RegW, MemW, Branch, ALUOp);

    always_comb
    if (ALUOp) begin // which Data-processing Instr?
        case(Funct[4:1])
            4'b0100: begin ALUControl = 3'b000; // ADD
                Shift = 1'b0;
                NoWrite = 1'b0;
            end
            4'b0010: begin ALUControl = 3'b001; // SUB
                Shift = 1'b0;
                NoWrite = 1'b0;
            end
            4'b0000: begin ALUControl = 3'b010; // AND
                Shift = 1'b0;
                NoWrite = 1'b0;
            end
            4'b1100: begin ALUControl = 3'b011; // ORR
                Shift = 1'b0;
                NoWrite = 1'b0;
            end
            4'b1101: begin ALUControl = 3'b000; // ASR, ROR
                Shift = 1'b1;
                NoWrite = 1'b0;
            end
            4'b1000: begin ALUControl = 3'b010; // TST

```

```

        Shift = 1'b0;
        NoWrite = 1'b1;
    end
    4'b0110: begin ALUControl = 3'b101; // SBC
        Shift = 1'b0;
        NoWrite = 1'b0;
    end
    default: begin ALUControl = 3'bx;
        Shift = 1'bx;
        NoWrite = 1'bx;
    end
endcase

FlagW[1] = Funct[0]; // update N & Z flags if S bit is set
FlagW[0] = Funct[0] & (ALUControl[1:0] == 2'b00 |
    ALUControl[1:0] == 2'b01);

end else begin
    ALUControl = 3'b000; // add for non data-processing instructions
    FlagW = 2'b00; // don't update Flags
    Shift = 1'b0; // don't shift
    NoWrite = 1'b0; // write result
end

// PC Logic
assign PCS = ((Rd == 4'b1111) & RegW) | Branch;

// Instr Decoder
assign ImmSrc = Op;
assign RegSrc[0] = (Op == 2'b10); // read PC on Branch
assign RegSrc[1] = (Op == 2'b01); // read Rd on STR
endmodule

module mainfsm(input logic clk,
    input logic reset,
    input logic [1:0] Op,
    input logic [5:0] Funct,
    output logic IRWrite,
    output logic AdrSrc, ALUSrcA,
    output logic [1:0] ALUSrcB, ResultSrc,
    output logic NextPC, RegW, MemW, Branch, ALUOp);

typedef enum logic [3:0] {FETCH, DECODE, MEMADR, MEMRD, MEMWB,
    MEMWR, EXECUTER, EXECUTEI, ALUWB, BRANCH,
    UNKNOWN}

statetype;

statetype state, nextstate;
logic [11:0] controls;

// state register
always @(posedge clk or posedge reset)
    if (reset) state <= FETCH;
    else state <= nextstate;

```

```

// next state logic
always_comb
  casex(state)
    FETCH:                                nextstate = DECODE;
    DECODE: case(Op)
      2'b00:
        if (Funct[5]) nextstate = EXECUTEI;
        else           nextstate = EXECUTER;
      2'b01:           nextstate = MEMADR;
      2'b10:           nextstate = BRANCH;
      default:         nextstate = UNKNOWN;
    endcase
    EXECUTER:           nextstate = ALUWB;
    EXECUTEI:          nextstate = ALUWB;
    MEMADR:
      if (Funct[0])    nextstate = MEMRD;
      else             nextstate = MEMWR;
    MEMRD:             nextstate = MEMWB;
    default:           nextstate = FETCH;
  endcase

// state-dependent output logic
always_comb
  case(state)
    FETCH:    controls = 12'b10001_010_1100;
    DECODE:   controls = 12'b00000_010_1100;
    EXECUTER: controls = 12'b00000_000_0001;
    EXECUTEI: controls = 12'b00000_000_0011;
    ALUWB:    controls = 12'b00010_000_0000;
    MEMADR:   controls = 12'b00000_000_0010;
    MEMWR:    controls = 12'b00100_100_0000;
    MEMRD:    controls = 12'b00000_100_0000;
    MEMWB:    controls = 12'b00010_001_0000;
    BRANCH:   controls = 12'b01000_010_0010;
    default:  controls = 12'bxxxxx_xxx_xxxx;
  endcase

  assign {NextPC, Branch, MemW, RegW, IRWrite,
        AdrSrc, ResultSrc,
        ALUSrcA, ALUSrcB, ALUOp} = controls;
endmodule

module condlogic(input  logic      clk, reset,
                input  logic [3:0] Cond,
                input  logic [3:0] ALUFlags,
                input  logic [1:0] FlagW,
                input  logic      PCS, NextPC, RegW, MemW,
                output logic      PCWrite, RegWrite, MemWrite,
                output logic      carry, // SBC
                input  logic      NoWrite); // TST

  logic [1:0] FlagWrite;
  logic [3:0] Flags;
  logic      CondEx, CondExDelayed;

```

```

logic          NoWriteDelayed;    // TST

flopnr #(2)flagreg1(clk, reset, FlagWrite[1], ALUFlags[3:2],
Flags[3:2]);
flopnr #(2)flagreg0(clk, reset, FlagWrite[0], ALUFlags[1:0],
Flags[1:0]);

// write controls are conditional
condcheck cc(Cond, Flags, CondEx);
flopnr #(1)nowritereg(clk, reset, NoWrite, NoWriteDelayed);
flopnr #(1)condreg(clk, reset, CondEx, CondExDelayed);
assign FlagWrite = FlagW & {2{CondEx}};
assign RegWrite  = RegW  & CondExDelayed & ~NoWriteDelayed; // TST
assign MemWrite  = MemW  & CondExDelayed;
assign PCWrite   = (PCS  & CondExDelayed) | NextPC;

assign carry     = Flags[1]; // SBC
endmodule

module condcheck(input  logic [3:0] Cond,
                 input  logic [3:0] Flags,
                 output logic      CondEx);

logic neg, zero, carry, overflow, ge;

assign {neg, zero, carry, overflow} = Flags;
assign ge = (neg == overflow);

always_comb
case(Cond)
  4'b0000: CondEx = zero;           // EQ
  4'b0001: CondEx = ~zero;         // NE
  4'b0010: CondEx = carry;         // CS
  4'b0011: CondEx = ~carry;        // CC
  4'b0100: CondEx = neg;           // MI
  4'b0101: CondEx = ~neg;         // PL
  4'b0110: CondEx = overflow;     // VS
  4'b0111: CondEx = ~overflow;    // VC
  4'b1000: CondEx = carry & ~zero; // HI
  4'b1001: CondEx = ~(carry & ~zero); // LS
  4'b1010: CondEx = ge;           // GE
  4'b1011: CondEx = ~ge;         // LT
  4'b1100: CondEx = ~zero & ge;   // GT
  4'b1101: CondEx = ~(~zero & ge); // LE
  4'b1110: CondEx = 1'b1;        // Always
  default: CondEx = 1'bx;        // undefined
endcase
endmodule

module datapath(input  logic      clk, reset,
                output logic [31:0] Adr, WriteData,
                input  logic [31:0] ReadData,
                output logic [31:0] Instr,
                output logic [3:0]  ALUFlags,

```

```

        input  logic      PCWrite, RegWrite,
        input  logic      IRWrite,
        input  logic      AdrSrc,
        input  logic [1:0] RegSrc,
        input  logic      ALUSrcA,
        input  logic [1:0] ALUSrcB, ResultSrc,
        input  logic [1:0] ImmSrc,
        input  logic [2:0] ALUControl, // SBC
        input  logic      carry,      // SBC
        input  logic      Shift);     // ASR, ROR

logic [31:0] PCNext, PC;
logic [31:0] ExtImm, SrcA, SrcB, Result;
logic [31:0] Data, RD1, RD2, A, ALUResult, ALUOut;
logic [3:0] RA1, RA2;
logic [31:0] srcBshifted, ALUResultOut; // ASR, ROR

// next PC logic
flopnr #(32) pcreg(clk, reset, PCWrite, Result, PC);

// memory logic
mux2 #(32) adrmux(PC, ALUOut, AdrSrc, Adr);
flopnr #(32) ir(clk, reset, IRWrite, ReadData, Instr);
flopnr #(32) datareg(clk, reset, ReadData, Data);

// register file logic
mux2 #(4) ralmux(Instr[19:16], 4'b1111, RegSrc[0], RA1);
mux2 #(4) ra2mux(Instr[3:0], Instr[15:12], RegSrc[1], RA2);
regfile rf(clk, RegWrite, RA1, RA2,
           Instr[15:12], Result, Result,
           RD1, RD2);
flopnr #(32) srcareg(clk, reset, RD1, A);
flopnr #(32) wdreg(clk, reset, RD2, WriteData);
extend ext(Instr[23:0], ImmSrc, ExtImm);

// ALU logic
mux2 #(32) srcamux(A, PC, ALUSrcA, SrcA);
// ASR, ROR
mux3 #(32) srcbmux(srcBshifted, ExtImm, 32'd4, ALUSrcB, SrcB);
shifter sh(WriteData, Instr[11:7], Instr[6:5], srcBshifted);
alu alu(SrcA, SrcB, ALUControl, ALUResult, ALUFlags, carry);
mux2 #(32) alureultmux(ALUResult, SrcB, Shift, ALUResultOut);
flopnr #(32) aluoutreg(clk, reset, ALUResultOut, ALUOut);
mux3 #(32) resmux(ALUOut, Data, ALUResultOut, ResultSrc, Result);
endmodule

module regfile(input logic clk,
              input logic we3,
              input logic [3:0] ra1, ra2, wa3,
              input logic [31:0] wd3, r15,
              output logic [31:0] rd1, rd2);

logic [31:0] rf[14:0];

```

```

// three ported register file
// read two ports combinationally
// write third port on rising edge of clock
// register 15 reads PC+8 instead

always_ff @(posedge clk)
    if (we3) rf[wa3] <= wd3;

assign rd1 = (ra1 == 4'b1111) ? r15 : rf[ra1];
assign rd2 = (ra2 == 4'b1111) ? r15 : rf[ra2];
endmodule

module extend(input  logic [23:0] Instr,
              input  logic [1:0] ImmSrc,
              output logic [31:0] ExtImm);

always_comb
    case(ImmSrc)
        // 8-bit unsigned immediate
        2'b00: ExtImm = {24'b0, Instr[7:0]};
        // 12-bit unsigned immediate
        2'b01: ExtImm = {20'b0, Instr[11:0]};
        // 24-bit two's complement shifted branch
        2'b10: ExtImm = {{6{Instr[23]}}, Instr[23:0], 2'b00};
        default: ExtImm = 32'bx; // undefined
    endcase
endmodule

module adder #(parameter WIDTH=8)
    (input  logic [WIDTH-1:0] a, b,
     output logic [WIDTH-1:0] y);

    assign y = a + b;
endmodule

module flopenr #(parameter WIDTH = 8)
    (input  logic          clk, reset, en,
     input  logic [WIDTH-1:0] d,
     output logic [WIDTH-1:0] q);

always_ff @(posedge clk, posedge reset)
    if (reset) q <= 0;
    else if (en) q <= d;
endmodule

module flopr #(parameter WIDTH = 8)
    (input  logic          clk, reset,
     input  logic [WIDTH-1:0] d,
     output logic [WIDTH-1:0] q);

always_ff @(posedge clk, posedge reset)
    if (reset) q <= 0;
    else      q <= d;
endmodule

```



```

endmodule

module mux2 #(parameter WIDTH = 8)
    (input  logic [WIDTH-1:0] d0, d1,
     input  logic          s,
     output logic [WIDTH-1:0] y);

    assign y = s ? d1 : d0;
endmodule

module mux3 #(parameter WIDTH = 8)
    (input  logic [WIDTH-1:0] d0, d1, d2,
     input  logic [1:0]      s,
     output logic [WIDTH-1:0] y);

    assign y = s[1] ? d2 : (s[0] ? d1 : d0);
endmodule

module alu(input  logic [31:0] a, b,
           input  logic [2:0]  ALUControl, // SBC
           output logic [31:0] Result,
           output logic [3:0]  ALUFlags,
           input  logic        carry);    // SBC

    logic      neg, zero, carryout, overflow;
    logic [31:0] condinvb;
    logic [32:0] sum;
    logic      carryin;                // SBC                // SBC

    assign carryin = ALUControl[2] ? carry : ALUControl[0]; // SBC

    assign condinvb = ALUControl[0] ? ~b : b;
    assign sum = a + condinvb + carryin;    // SBC

    always_comb
        casex (ALUControl[1:0])
            2'b0?: Result = sum;
            2'b10: Result = a & b;
            2'b11: Result = a | b;
        endcase

    assign neg      = Result[31];
    assign zero     = (Result == 32'b0);
    assign carryout = (ALUControl[1] == 1'b0) & sum[32];
    assign overflow = (ALUControl[1] == 1'b0) & ~(a[31] ^ b[31] ^
        ALUControl[0]) & (a[31] ^ sum[31]);
    assign ALUFlags = {neg, zero, carryout, overflow};
endmodule

// shifter needed for ASR, ROR
module shifter(input  logic signed [31:0] a,
              input  logic          [ 4:0] shamt,

```

```

        input logic          [ 1:0] shtype,
        output logic signed [31:0] y);

always_comb
  case (shtype)
    2'b10: y = a >>> shamt;
    2'b11: y = (a >> shamt) | (a << (32-shamt));
    default: y = a;
  endcase
endmodule

VHDL
library IEEE;
use IEEE.STD_LOGIC_1164.all; use IEEE.NUMERIC_STD_UNSIGNED.all;
entity testbench is
end;

architecture test of testbench is
  component top
    port (clk, reset:          in  STD_LOGIC;
          WriteData, Adr:      out STD_LOGIC_VECTOR(31 downto 0);
          MemWrite:           out STD_LOGIC);
  end component;
  signal WriteData, DataAdr:    STD_LOGIC_VECTOR(31 downto 0);
  signal clk, reset, MemWrite: STD_LOGIC;
begin

  -- instantiate device to be tested
  dut: top port map (clk, reset, WriteData, DataAdr, MemWrite);

  -- Generate clock with 10 ns period
  process begin
    clk <= '1';
    wait for 5 ns;
    clk <= '0';
    wait for 5 ns;
  end process;

  -- Generate reset for first two clock cycles
  process begin
    reset <= '1';
    wait for 22 ns;
    reset <= '0';
    wait;
  end process;

  -- check that 7 gets written to address 84
  -- at end of program
  process (clk) begin
    if (clk'event and clk = '0' and MemWrite = '1') then
      if (to_integer(DataAdr) = 88 and
          to_integer(WriteData) = 32X"2FFFFFFE") then
        report "NO ERRORS: Simulation succeeded" severity failure;
      else

```

```

        report "Simulation failed" severity failure;
    end if;
end if;
end process;
end;

```

```

library IEEE;
use IEEE.STD_LOGIC_1164.all; use IEEE.NUMERIC_STD_UNSIGNED.all;
entity top is -- top-level design for testing
    port(clk, reset:          in    STD_LOGIC;
          WriteData, Adr:     buffer STD_LOGIC_VECTOR(31 downto 0);
          MemWrite:           buffer STD_LOGIC);
end;

```

```

architecture test of top is
    component arm
        port(clk, reset:          in    STD_LOGIC;
              MemWrite:          out   STD_LOGIC;
              Adr, WriteData:    out   STD_LOGIC_VECTOR(31 downto 0);
              ReadData:          in    STD_LOGIC_VECTOR(31 downto 0));
    end component;
    component mem
        port(clk, we:  in    STD_LOGIC;
              a, wd:  in    STD_LOGIC_VECTOR(31 downto 0);
              rd:     out   STD_LOGIC_VECTOR(31 downto 0));
    end component;
    signal ReadData: STD_LOGIC_VECTOR(31 downto 0);
begin
    -- instantiate processor and memories
    i_arm: arm port map(clk, reset, MemWrite, Adr,
                       WriteData, ReadData);
    i_mem: mem port map(clk, MemWrite, Adr,
                       WriteData, ReadData);
end;

```

```

library IEEE;
use IEEE.STD_LOGIC_1164.all; use STD.TEXTIO.all;
use IEEE.NUMERIC_STD_UNSIGNED.all;
entity mem is -- memory
    port(clk, we:  in    STD_LOGIC;
          a, wd:  in    STD_LOGIC_VECTOR(31 downto 0);
          rd:     out   STD_LOGIC_VECTOR(31 downto 0));
end;

```

```

architecture behave of mem is -- instruction and data memory
begin
    process is
        file mem_file: TEXT;
        variable L: line;
        variable ch: character;
        variable i, index, result: integer;

        type ramtype is array (63 downto 0) of

```

```

        STD_LOGIC_VECTOR(31 downto 0);
    variable ram: ramtype;
begin
    -- initialize memory from file
    for i in 0 to 63 loop -- set all contents low
        ram(i) := (others => '0');
    end loop;
    index := 0;
    FILE_OPEN(mem_file, "ex7.27_memfile.dat", READ_MODE);
    while not endfile(mem_file) loop
        readline(mem_file, L);
        result := 0;
        for i in 1 to 8 loop
            read(L, ch);
            if '0' <= ch and ch <= '9' then
                result := character'pos(ch) - character'pos('0');
            elsif 'a' <= ch and ch <= 'f' then
                result := character'pos(ch) - character'pos('a')+10;
            elsif 'A' <= ch and ch <= 'F' then
                result := character'pos(ch) - character'pos('A')+10;
            else report "Format error on line " & integer'image(index)
                severity error;
            end if;
            ram(index)(35-i*4 downto 32-i*4) :=
                to_std_logic_vector(result,4);
        end loop;
        index := index + 1;
    end loop;

    -- read or write memory
    loop
        if clk'event and clk = '1' then
            if (we = '1') then
                ram(to_integer(a(7 downto 2))) := wd;
            end if;
        end if;
        rd <= ram(to_integer(a(7 downto 2)));
        wait on clk, a;
    end loop;
end process;
end;

library IEEE; use IEEE.STD_LOGIC_1164.all;
entity arm is -- multicycle processor
    port(clk, reset:          in  STD_LOGIC;
         MemWrite:           out STD_LOGIC;
         Adr, WriteData:     out STD_LOGIC_VECTOR(31 downto 0);
         ReadData:           in  STD_LOGIC_VECTOR(31 downto 0));
end;

architecture struct of arm is
    component controller

```

```

port (clk, reset:          in  STD_LOGIC;
      Instr:              in  STD_LOGIC_VECTOR(31 downto 12);
      ALUFlags:           in  STD_LOGIC_VECTOR(3 downto 0);
      PCWrite:            out STD_LOGIC;
      MemWrite:           out STD_LOGIC;
      RegWrite:           out STD_LOGIC;
      IRWrite:            out STD_LOGIC;
      AdrSrc:             out STD_LOGIC;
      RegSrc:             out STD_LOGIC_VECTOR(1 downto 0);
      ALUSrcA:            out STD_LOGIC;
      ALUSrcB:            out STD_LOGIC_VECTOR(1 downto 0);
      ResultSrc:          out STD_LOGIC_VECTOR(1 downto 0);
      ImmSrc:             out STD_LOGIC_VECTOR(1 downto 0);
      ALUControl:         out STD_LOGIC_VECTOR(2 downto 0); -- SBC
      carry, Shift:       out STD_LOGIC); -- SBC, ASR, ROR

end component;
component datapath
  port (clk, reset:          in  STD_LOGIC;
        Adr:                out STD_LOGIC_VECTOR(31 downto 0);
        WriteData:          out STD_LOGIC_VECTOR(31 downto 0);
        ReadData:           in  STD_LOGIC_VECTOR(31 downto 0);
        Instr:              out STD_LOGIC_VECTOR(31 downto 0);
        ALUFlags:           out STD_LOGIC_VECTOR(3 downto 0);
        PCWrite:            in  STD_LOGIC;
        RegWrite:           in  STD_LOGIC;
        IRWrite:            in  STD_LOGIC;
        AdrSrc:             in  STD_LOGIC;
        RegSrc:             in  STD_LOGIC_VECTOR(1 downto 0);
        ALUSrcA:            in  STD_LOGIC;
        ALUSrcB:            in  STD_LOGIC_VECTOR(1 downto 0);
        ResultSrc:          in  STD_LOGIC_VECTOR(1 downto 0);
        ImmSrc:             in  STD_LOGIC_VECTOR(1 downto 0);
        ALUControl:         in  STD_LOGIC_VECTOR(2 downto 0); -- SBC
        carry, Shift:       in  STD_LOGIC); -- SBC, ASR, ROR
end component;
signal Instr: STD_LOGIC_VECTOR(31 downto 0);
signal ALUFlags: STD_LOGIC_VECTOR(3 downto 0);
signal PCWrite, RegWrite, IRWrite: STD_LOGIC;
signal AdrSrc, ALUSrcA: STD_LOGIC;
signal RegSrc, ALUSrcB: STD_LOGIC_VECTOR(1 downto 0);
signal ImmSrc, ResultSrc: STD_LOGIC_VECTOR(1 downto 0);
signal ALUControl: STD_LOGIC_VECTOR(2 downto 0); -- SBC
signal carry: STD_LOGIC; -- SBC
signal Shift: STD_LOGIC; -- ASR, ROR
begin
  cont: controller port map(clk, reset, Instr(31 downto 12),
                           ALUFlags, PCWrite, MemWrite, RegWrite,
                           IRWrite, AdrSrc, RegSrc, ALUSrcA,
                           ALUSrcB, ResultSrc, ImmSrc, ALUControl,
                           carry, Shift); -- SBC, ASR, ROR

  dp: datapath port map(clk, reset, Adr, WriteData, ReadData,
                       Instr, ALUFlags,

```

```

        PCWrite, RegWrite, IRWrite,
        AdrSrc, RegSrc, ALUSrcA, ALUSrcB, ResultSrc,
        ImmSrc, ALUControl,
        carry, Shift); -- SBC, ASR, ROR
end;

```

```

library IEEE; use IEEE.STD_LOGIC_1164.all;
entity controller is -- single cycle control decoder
    port (clk, reset:          in  STD_LOGIC;
          Instr:              in  STD_LOGIC_VECTOR(31 downto 12);
          ALUFlags:           in  STD_LOGIC_VECTOR(3 downto 0);
          PCWrite:            out STD_LOGIC;
          MemWrite:           out STD_LOGIC;
          RegWrite:           out STD_LOGIC;
          IRWrite:            out STD_LOGIC;
          AdrSrc:             out STD_LOGIC;
          RegSrc:             out STD_LOGIC_VECTOR(1 downto 0);
          ALUSrcA:            out STD_LOGIC;
          ALUSrcB:            out STD_LOGIC_VECTOR(1 downto 0);
          ResultSrc:          out STD_LOGIC_VECTOR(1 downto 0);
          ImmSrc:             out STD_LOGIC_VECTOR(1 downto 0);
          ALUControl:         out STD_LOGIC_VECTOR(2 downto 0); -- SBC
          carry, Shift:       out STD_LOGIC); -- SBC, ASR, ROR

```

```

end;
architecture struct of controller is
    component decoder
        port (clk, reset:          in  STD_LOGIC;
              Op:                 in  STD_LOGIC_VECTOR(1 downto 0);
              Funct:              in  STD_LOGIC_VECTOR(5 downto 0);
              Rd:                 in  STD_LOGIC_VECTOR(3 downto 0);
              FlagW:              out STD_LOGIC_VECTOR(1 downto 0);
              PCS, NextPC:        out STD_LOGIC;
              RegW, MemW:         out STD_LOGIC;
              IRWrite, AdrSrc:    out STD_LOGIC;
              ResultSrc:         out STD_LOGIC_VECTOR(1 downto 0);
              ALUSrcA:            out STD_LOGIC;
              ALUSrcB, ImmSrc:   out STD_LOGIC_VECTOR(1 downto 0);
              RegSrc:             out STD_LOGIC_VECTOR(1 downto 0);
              ALUControl:        out STD_LOGIC_VECTOR(2 downto 0); -- SBC
              NoWrite:            out STD_LOGIC; -- TST
              Shift:              out STD_LOGIC); -- ASR, ROR
    end component;
    component condlogic
        port (clk, reset:          in  STD_LOGIC;
              Cond:               in  STD_LOGIC_VECTOR(3 downto 0);
              ALUFlags:           in  STD_LOGIC_VECTOR(3 downto 0);
              FlagW:              in  STD_LOGIC_VECTOR(1 downto 0);
              PCS, NextPC:        in  STD_LOGIC;
              RegW, MemW:         in  STD_LOGIC;
              PCWrite, RegWrite:  out STD_LOGIC;
              MemWrite:           out STD_LOGIC;
              carry:              out STD_LOGIC); -- SBC

```

```

        NoWrite:          in STD_LOGIC); -- TST
    end component;
    signal FlagW: STD_LOGIC_VECTOR(1 downto 0);
    signal PCS, NextPC, RegW, MemW: STD_LOGIC;
    signal NoWrite: STD_LOGIC; -- TST
begin
    dec: decoder port map(clk, reset, Instr(27 downto 26), Instr(25 downto
20),
                        Instr(15 downto 12), FlagW, PCS,
                        NextPC, RegW, MemW,
                        IRWrite, AdrSrc, ResultSrc,
                        ALUSrcA, ALUSrcB, ImmSrc, RegSrc, ALUControl,
                        NoWrite, -- TST
                        Shift); -- ASR, ROR
    cl: condlogic port map(clk, reset, Instr(31 downto 28),
                        ALUFlags, FlagW, PCS, NextPC, RegW, MemW,
                        PCWrite, RegWrite, MemWrite,
                        carry, -- SBC
                        NoWrite); -- TST
end;

library IEEE; use IEEE.STD_LOGIC_1164.all;
entity decoder is -- main control decoder
    port(clk, reset:      in STD_LOGIC;
          Op:             in STD_LOGIC_VECTOR(1 downto 0);
          Funct:         in STD_LOGIC_VECTOR(5 downto 0);
          Rd:            in STD_LOGIC_VECTOR(3 downto 0);
          FlagW:         out STD_LOGIC_VECTOR(1 downto 0);
          PCS, NextPC:   out STD_LOGIC;
          RegW, MemW:    out STD_LOGIC;
          IRWrite, AdrSrc: out STD_LOGIC;
          ResultSrc:     out STD_LOGIC_VECTOR(1 downto 0);
          ALUSrcA:       out STD_LOGIC;
          ALUSrcB, ImmSrc: out STD_LOGIC_VECTOR(1 downto 0);
          RegSrc:        out STD_LOGIC_VECTOR(1 downto 0);
          ALUControl:    out STD_LOGIC_VECTOR(2 downto 0); -- SBC
          NoWrite:       out STD_LOGIC; -- TST
          Shift:         out STD_LOGIC); -- ASR, ROR
end;

architecture behave of decoder is
    component mainfsm
        port(clk, reset:      in STD_LOGIC;
              Op:             in STD_LOGIC_VECTOR(1 downto 0);
              Funct:         in STD_LOGIC_VECTOR(5 downto 0);
              IRWrite:       out STD_LOGIC;
              AdrSrc, ALUSrcA: out STD_LOGIC;
              ALUSrcB:       out STD_LOGIC_VECTOR(1 downto 0);
              ResultSrc:     out STD_LOGIC_VECTOR(1 downto 0);
              NextPC, RegW:   out STD_LOGIC;
              MemW, Branch:   out STD_LOGIC;
              ALUOp:         out STD_LOGIC);
    end component;
    signal Branch, ALUOp: STD_LOGIC;

```

```

begin
  -- Main FSM
  fsm: mainfsm port map(clk, reset, Op, Funct,
                        IRWrite, AdrSrc,
                        ALUSrcA, ALUSrcB, ResultSrc,
                        NextPC, RegW, MemW, Branch, ALUOp);

  process(all) begin -- ALU Decoder
    if (ALUOp) then
      case Funct(4 downto 1) is
        when "0100" => ALUControl <= "000"; -- ADD
                      NoWrite <= '0';
                      Shift <= '0';
        when "0010" => ALUControl <= "001"; -- SUB
                      NoWrite <= '0';
                      Shift <= '0';
        when "0000" => ALUControl <= "010"; -- AND
                      NoWrite <= '0';
                      Shift <= '0';
        when "1100" => ALUControl <= "011"; -- ORR
                      NoWrite <= '0';
                      Shift <= '0';
        when "1101" => ALUControl <= "010"; -- ASR, ROR
                      NoWrite <= '0';
                      Shift <= '1';
        when "1000" => ALUControl <= "010"; -- TST
                      NoWrite <= '1';
                      Shift <= '0';
        when "0110" => ALUControl <= "101"; -- SBC
                      NoWrite <= '0';
                      Shift <= '0';
        when others => ALUControl <= "----"; -- unimplemented
                      NoWrite <= '-';
                      Shift <= '-';

      end case;
      FlagW(1) <= Funct(0);
      FlagW(0) <= Funct(0) and (not ALUControl(1));
    else
      ALUControl <= "000";
      FlagW <= "00";
      Shift <= '0';
      NoWrite <= '0';
    end if;
  end process;

  -- PC Logic
  PCS <= ((and Rd) and RegW) or Branch;

  -- Instr Decoder
  ImmSrc <= Op;
  RegSrc(0) <= '1' when (Op = 2B"10") else '0';
  RegSrc(1) <= '1' when (Op = 2B"01") else '0';
end;

```



```

library IEEE; use IEEE.STD_LOGIC_1164.all;
entity mainfsm is
  port (clk, reset:      in  STD_LOGIC;
        Op:              in  STD_LOGIC_VECTOR(1 downto 0);
        Funct:           in  STD_LOGIC_VECTOR(5 downto 0);
        IRWrite:         out STD_LOGIC;
        AdrSrc, ALUSrcA: out STD_LOGIC;
        ALUSrcB:         out STD_LOGIC_VECTOR(1 downto 0);
        ResultSrc:       out STD_LOGIC_VECTOR(1 downto 0);
        NextPC, RegW:     out STD_LOGIC;
        MemW, Branch:     out STD_LOGIC;
        ALUOp:           out STD_LOGIC);
end;

architecture synth of mainfsm is
  type statetype is (FETCH, DECODE, MEMADR, MEMRD, MEMWB, MEMWR,
                    EXECUTER, EXECUTEI, ALUWB, BR, UNKNOWN);
  signal state, nextstate: statetype;
  signal controls: STD_LOGIC_VECTOR(11 downto 0);
begin
  --state register
  process(clk, reset) begin
    if reset then state <= FETCH;
    elsif rising_edge(clk) then
      state <= nextstate;
    end if;
  end process;

  -- next state logic
  process(all) begin
    case state is
      when FETCH =>      nextstate <= DECODE;
      when DECODE =>
        case Op is
          when "00" =>   nextstate <= ExecuteI when (Funct(5) = '1')
                        else EXECUTER;
          when "01" =>   nextstate <= MEMADR;
          when "10" =>   nextstate <= BR;
          when others => nextstate <= UNKNOWN;
        end case;
      when EXECUTER =>   nextstate <= ALUWB;
      when EXECUTEI =>   nextstate <= ALUWB;
      when MEMADR  =>   nextstate <= MEMRD when (Funct(0) = '1')
                        else MEMWR;
      when MEMRD   =>   nextstate <= MEMWB;
      when others  =>   nextstate <= FETCH;
    end case;
  end process;

  -- state-dependent output logic
  process(all) begin
    case state is
      when FETCH =>     controls <= 12B"100010101100";
    end case;
  end process;
end;

```

```

when DECODE => controls <= 12B"000000101100";
when EXECUTER => controls <= 12B"000000000001";
when EXECUTEI => controls <= 12B"000000000011";
when ALUWB => controls <= 12B"000100000000";
when MEMADR => controls <= 12B"000000000010";
when MEMWR => controls <= 12B"001001000000";
when MEMRD => controls <= 12B"000001000000";
when MEMWB => controls <= 12B"000100010000";
when BR => controls <= 12B"010000100010";
when others => controls <= "XXXXXXXXXXXX";
end case;
end process;

(NextPC, Branch, MemW, RegW, IRWrite,
AdrSrc, ResultSrc,
ALUSrcA, ALUSrcB, ALUOp) <= controls;
end;

library IEEE; use IEEE.STD_LOGIC_1164.all;
entity condlogic is -- Conditional logic
  port (clk, reset:      in  STD_LOGIC;
        Cond:           in  STD_LOGIC_VECTOR(3 downto 0);
        ALUFlags:       in  STD_LOGIC_VECTOR(3 downto 0);
        FlagW:          in  STD_LOGIC_VECTOR(1 downto 0);
        PCS, NextPC:    in  STD_LOGIC;
        RegW, MemW:     in  STD_LOGIC;
        PCWrite, RegWrite: out STD_LOGIC;
        MemWrite:       out  STD_LOGIC;
        carry:          out  STD_LOGIC; -- SBC
        NoWrite:        in  STD_LOGIC); -- TST
end;

architecture behave of condlogic is
  component condcheck
    port (Cond:           in  STD_LOGIC_VECTOR(3 downto 0);
          Flags:         in  STD_LOGIC_VECTOR(3 downto 0);
          CondEx:        out  STD_LOGIC);
  end component;
  component flopenr generic (width: integer);
    port (clk, reset, en: in  STD_LOGIC;
          d:             in  STD_LOGIC_VECTOR(width-1 downto 0);
          q:             out  STD_LOGIC_VECTOR(width-1 downto 0));
  end component;
  component flopr generic (width: integer);
    port (clk, reset: in  STD_LOGIC;
          d:          in  STD_LOGIC_VECTOR(width-1 downto 0);
          q:          out  STD_LOGIC_VECTOR(width-1 downto 0));
  end component;

  signal FlagWrite: STD_LOGIC_VECTOR(1 downto 0);
  signal Flags:     STD_LOGIC_VECTOR(3 downto 0);
  signal CondEx:    STD_LOGIC_VECTOR(0 downto 0);
  signal CondExDelayed: STD_LOGIC_VECTOR(0 downto 0);
  signal NoWritevect: STD_LOGIC_VECTOR(0 downto 0); -- TST

```

```

    signal NoWriteDelayed: STD_LOGIC_VECTOR(0 downto 0); -- TST
begin

    NoWritevect(0) <= NoWrite;
    flagreg1: flopenr generic map(2)
        port map(clk, reset, FlagWrite(1),
            ALUFlags(3 downto 2), Flags(3 downto 2));
    flagreg0: flopenr generic map(2)
        port map(clk, reset, FlagWrite(0),
            ALUFlags(1 downto 0), Flags(1 downto 0));
    cc: condcheck port map(Cond, Flags, CondEx(0));
    condreg: flopr generic map(1)
        port map(clk, reset, CondEx, CondExDelayed);
    nowritereg: flopr generic map(1)
        port map(clk, reset, NoWritevect, NoWriteDelayed);

    FlagWrite <= FlagW and (CondEx(0), CondEx(0));
    RegWrite <= RegW and CondExDelayed(0) and (not NoWriteDelayed(0)); --
TST
    MemWrite <= MemW and CondExDelayed(0);
    PCWrite <= (PCS and CondExDelayed(0)) or NextPC;
    carry <= Flags(1); -- SBC
end;

library IEEE; use IEEE.STD_LOGIC_1164.all;
entity condcheck is
    port(Cond:          in  STD_LOGIC_VECTOR(3 downto 0);
         Flags:        in  STD_LOGIC_VECTOR(3 downto 0);
         CondEx:       out STD_LOGIC);
end;

architecture behave of condcheck is
    signal neg, zero, carry, overflow, ge: STD_LOGIC;
begin
    (neg, zero, carry, overflow) <= Flags;
    ge <= (neg xnor overflow);

    process(all) begin -- Condition checking
        case Cond is
            when "0000" => CondEx <= zero;
            when "0001" => CondEx <= not zero;
            when "0010" => CondEx <= carry;
            when "0011" => CondEx <= not carry;
            when "0100" => CondEx <= neg;
            when "0101" => CondEx <= not neg;
            when "0110" => CondEx <= overflow;
            when "0111" => CondEx <= not overflow;
            when "1000" => CondEx <= carry and (not zero);
            when "1001" => CondEx <= not(carry and (not zero));
            when "1010" => CondEx <= ge;
            when "1011" => CondEx <= not ge;
            when "1100" => CondEx <= (not zero) and ge;
            when "1101" => CondEx <= not ((not zero) and ge);
        end case;
    end process;
end behave;

```

```

        when "1110" => CondEx <= '1';
        when others => CondEx <= '-';
    end case;
end process;
end;

library IEEE; use IEEE.STD_LOGIC_1164.all;
entity datapath is
    port (clk, reset:          in  STD_LOGIC;
          Adr:                out STD_LOGIC_VECTOR(31 downto 0);
          WriteData:          out STD_LOGIC_VECTOR(31 downto 0);
          ReadData:           in  STD_LOGIC_VECTOR(31 downto 0);
          Instr:              out STD_LOGIC_VECTOR(31 downto 0);
          ALUFlags:           out STD_LOGIC_VECTOR(3 downto 0);
          PCWrite:            in  STD_LOGIC;
          RegWrite:           in  STD_LOGIC;
          IRWrite:            in  STD_LOGIC;
          AdrSrc:             in  STD_LOGIC;
          RegSrc:             in  STD_LOGIC_VECTOR(1 downto 0);
          ALUSrcA:            in  STD_LOGIC;
          ALUSrcB:            in  STD_LOGIC_VECTOR(1 downto 0);
          ResultSrc:          in  STD_LOGIC_VECTOR(1 downto 0);
          ImmSrc:             in  STD_LOGIC_VECTOR(1 downto 0);
          ALUControl:         in  STD_LOGIC_VECTOR(2 downto 0); -- SBC
          carry, Shift:       in  STD_LOGIC); -- SBC, ASR, ROR
end;

architecture struct of datapath is
    component alu
        port (a, b:           in  STD_LOGIC_VECTOR(31 downto 0);
              ALUControl:    in  STD_LOGIC_VECTOR(2 downto 0); -- SBC
              Result:        buffer STD_LOGIC_VECTOR(31 downto 0);
              ALUFlags:      out STD_LOGIC_VECTOR(3 downto 0);
              carry:         in  STD_LOGIC); -- SBC
    end component;
    component regfile
        port (clk:           in  STD_LOGIC;
              we3:           in  STD_LOGIC;
              ral, ra2, wa3: in  STD_LOGIC_VECTOR(3 downto 0);
              wd3, r15:      in  STD_LOGIC_VECTOR(31 downto 0);
              rd1, rd2:      out STD_LOGIC_VECTOR(31 downto 0));
    end component;
    component adder
        port (a, b: in  STD_LOGIC_VECTOR(31 downto 0);
              y:   out STD_LOGIC_VECTOR(31 downto 0));
    end component;
    component extend
        port (Instr: in  STD_LOGIC_VECTOR(23 downto 0);
              ImmSrc: in  STD_LOGIC_VECTOR(1 downto 0);
              ExtImm: out STD_LOGIC_VECTOR(31 downto 0));
    end component;
    component flopenr generic (width: integer);
        port (clk, reset, en: in  STD_LOGIC;

```

```

        d:          in  STD_LOGIC_VECTOR(width-1 downto 0);
        q:          out STD_LOGIC_VECTOR(width-1 downto 0));
end component;
component flopr generic(width: integer);
port(clk, reset: in  STD_LOGIC;
      d:          in  STD_LOGIC_VECTOR(width-1 downto 0);
      q:          out STD_LOGIC_VECTOR(width-1 downto 0));
end component;
component mux2 generic(width: integer);
port(d0, d1: in  STD_LOGIC_VECTOR(width-1 downto 0);
      s:      in  STD_LOGIC;
      y:      out STD_LOGIC_VECTOR(width-1 downto 0));
end component;
component mux3 generic(width: integer);
port(d0, d1, d2: in  STD_LOGIC_VECTOR(width-1 downto 0);
      s:          in  STD_LOGIC_VECTOR(1 downto 0);
      y:          out STD_LOGIC_VECTOR(width-1 downto 0));
end component;
component shifter -- LSL
port(a:          in  STD_LOGIC_VECTOR(31 downto 0);
      shamt:     in  STD_LOGIC_VECTOR(4  downto 0);
      shtype:    in  STD_LOGIC_VECTOR(1  downto 0);
      y:          out STD_LOGIC_VECTOR(31 downto 0));
end component;

signal PCNext, PC: STD_LOGIC_VECTOR(31 downto 0);
signal ExtImm, SrcA, SrcB:          STD_LOGIC_VECTOR(31 downto 0);
signal Result:                     STD_LOGIC_VECTOR(31 downto 0);
signal Data, RD1, RD2, A:          STD_LOGIC_VECTOR(31 downto 0);
signal ALUResult, ALUOut:          STD_LOGIC_VECTOR(31 downto 0);
signal RA1, RA2:                   STD_LOGIC_VECTOR(3  downto 0);
signal srcBshifted, ALUResultOut: STD_LOGIC_VECTOR(31 downto 0); -- ASR,
ROR
begin
-- next PC logic
pcreg: flopenr generic map(32)
port map(clk, reset, PCWrite, Result, PC);

-- memory logic
adrmux: mux2 generic map(32)
port map(PC, ALUOut, AdrSrc, Adr);
ir: flopenr generic map(32)
port map(clk, reset, IRWrite, ReadData, Instr);
datareg: flopr generic map(32)
port map(clk, reset, ReadData, Data);

-- register file logic
ralmux: mux2 generic map (4)
port map(Instr(19 downto 16), "1111", RegSrc(0), RA1);
ra2mux: mux2 generic map (4) port map(Instr(3  downto 0),
Instr(15 downto 12), RegSrc(1), RA2);
rf: regfile port map(clk, RegWrite, RA1, RA2,
Instr(15 downto 12), Result, Result,
RD1, RD2);

```

```

srcareg: flopr generic map(32)
  port map(clk, reset, RD1, A);
wdreg: flopr generic map(32)
  port map(clk, reset, RD2, WriteData);
ext: extend port map(Instr(23 downto 0), ImmSrc, ExtImm);

-- ALU logic
srcamux: mux2 generic map(32)
  port map(A, PC, ALUSrcA, SrcA);

-- ASR, ROR
srcbmux: mux3 generic map (32)
  port map(srcBshifted, ExtImm, 32X"00000004", ALUSrcB, SrcB);
sh: shifter port map(WriteData, Instr(11 downto 7), Instr(6 downto 5),
srcBshifted);
i_alu: alu port map(SrcA, SrcB, ALUControl, ALUResult, ALUFlags, carry);
alureultmux: mux2 generic map(32)
  port map(ALUResult, SrcB, Shift, ALUResultOut);
aluoutreg: flopr generic map (32)
  port map(clk, reset, ALUResultOut, ALUOut);
resmux: mux3 generic map(32)
  port map(ALUOut, Data, ALUResultOut, ResultSrc, Result);
end;

library IEEE; use IEEE.STD_LOGIC_1164.all;
use IEEE.NUMERIC_STD_UNSIGNED.all;
entity regfile is -- three-port register file
  port(clk:          in  STD_LOGIC;
        we3:         in  STD_LOGIC;
        ra1, ra2, wa3: in  STD_LOGIC_VECTOR(3 downto 0);
        wd3, r15:    in  STD_LOGIC_VECTOR(31 downto 0);
        rd1, rd2:    out STD_LOGIC_VECTOR(31 downto 0));
end;

architecture behave of regfile is
  type ramtype is array (31 downto 0) of
    STD_LOGIC_VECTOR(31 downto 0);
  signal mem: ramtype;
begin
  process(clk) begin
    if rising_edge(clk) then
      if we3 = '1' then mem(to_integer(wa3)) <= wd3;
      end if;
    end if;
  end process;
  process(all) begin
    if (to_integer(ra1) = 15) then rd1 <= r15;
    else rd1 <= mem(to_integer(ra1));
    end if;
    if (to_integer(ra2) = 15) then rd2 <= r15;
    else rd2 <= mem(to_integer(ra2));
    end if;
  end process;
end;

```

```

library IEEE; use IEEE.STD_LOGIC_1164.all;
use IEEE.NUMERIC_STD_UNSIGNED.all;
entity adder is -- adder
  port(a, b: in  STD_LOGIC_VECTOR(31 downto 0);
        y:      out STD_LOGIC_VECTOR(31 downto 0));
end;

architecture behave of adder is
begin
  y <= a + b;
end;

library IEEE; use IEEE.STD_LOGIC_1164.all;
entity extend is
  port(Instr: in  STD_LOGIC_VECTOR(23 downto 0);
        ImmSrc: in  STD_LOGIC_VECTOR(1 downto 0);
        ExtImm: out STD_LOGIC_VECTOR(31 downto 0));
end;

architecture behave of extend is
begin
  process(all) begin
    case ImmSrc is
      when "00" => ExtImm <= (X"000000", Instr(7 downto 0));
      when "01" => ExtImm <= (X"00000", Instr(11 downto 0));
      when "10" => ExtImm <= (Instr(23), Instr(23), Instr(23),
        Instr(23), Instr(23), Instr(23), Instr(23 downto 0), "00");
      when others => ExtImm <= X"-----";
    end case;
  end process;
end;

library IEEE; use IEEE.STD_LOGIC_1164.all;
entity flopenr is -- flip-flop with enable and asynchronous reset
  generic(width: integer);
  port(clk, reset, en: in  STD_LOGIC;
        d:      in  STD_LOGIC_VECTOR(width-1 downto 0);
        q:      out STD_LOGIC_VECTOR(width-1 downto 0));
end;

architecture asynchronous of flopenr is
begin
  process(clk, reset) begin
    if reset then q <= (others => '0');
    elsif rising_edge(clk) then
      if en then
        q <= d;
      end if;
    end if;
  end process;
end;

library IEEE; use IEEE.STD_LOGIC_1164.all;

```

```

entity flopr is -- flip-flop with asynchronous reset
  generic(width: integer);
  port(clk, reset: in STD_LOGIC;
        d:          in  STD_LOGIC_VECTOR(width-1 downto 0);
        q:          out STD_LOGIC_VECTOR(width-1 downto 0));
end;

```

```

architecture asynchronous of flopr is
begin
  process(clk, reset) begin
    if reset then q <= (others => '0');
    elsif rising_edge(clk) then
      q <= d;
    end if;
  end process;
end;

```

```

library IEEE; use IEEE.STD_LOGIC_1164.all;
entity mux2 is -- two-input multiplexer
  generic(width: integer);
  port(d0, d1: in  STD_LOGIC_VECTOR(width-1 downto 0);
        s:      in  STD_LOGIC;
        y:      out STD_LOGIC_VECTOR(width-1 downto 0));
end;

```

```

architecture behave of mux2 is
begin
  y <= d1 when s else d0;
end;

```

```

library IEEE; use IEEE.STD_LOGIC_1164.all;
entity mux3 is -- three-input multiplexer
  generic(width: integer);
  port(d0, d1, d2: in  STD_LOGIC_VECTOR(width-1 downto 0);
        s:          in  STD_LOGIC_VECTOR(1 downto 0);
        y:          out STD_LOGIC_VECTOR(width-1 downto 0));
end;

```

```

architecture behave of mux3 is
begin
  process(all) begin
    case s is
      when "00" => y <= d0;
      when "01" => y <= d1;
      when "10" => y <= d2;
      when others => y <= d0;
    end case;
  end process;
end;

```

```

library IEEE; use IEEE.STD_LOGIC_1164.all;

```



```

use IEEE.NUMERIC_STD_UNSIGNED.all;
entity alu is
  port(a, b:          in  STD_LOGIC_VECTOR(31 downto 0);
        ALUControl: in  STD_LOGIC_VECTOR(2 downto 0); -- SBC
        Result:      buffer STD_LOGIC_VECTOR(31 downto 0);
        ALUFlags:    out STD_LOGIC_VECTOR(3 downto 0);
        carry:       in  STD_LOGIC); -- SBC
end;

architecture behave of alu is
  signal condinvb: STD_LOGIC_VECTOR(31 downto 0);
  signal sum:      STD_LOGIC_VECTOR(32 downto 0);
  signal neg, zero, carryout, overflow: STD_LOGIC;
  signal carryin: STD_LOGIC; -- SBC

begin
  carryin <= carry when ALUControl(2) else ALUControl(0);
  condinvb <= not b when ALUControl(0) else b;
  sum <= ('0', a) + ('0', condinvb) + carryin;

  process(all) begin
    case? ALUControl(1 downto 0) is
      when "0-" => result <= sum(31 downto 0);
      when "10" => result <= a and b;
      when "11" => result <= a or b;
      when others => result <= (others => '-');
    end case?;
  end process;

  neg <= Result(31);
  zero <= '1' when (Result = 0) else '0';
  carryout <= (not ALUControl(1)) and sum(32);
  overflow <= (not ALUControl(1)) and
    (not (a(31) xor b(31) xor ALUControl(0))) and
    (a(31) xor sum(31));
  ALUFlags <= (neg, zero, carryout, overflow);
end;

-- shifter needed for ASR, ROR
library IEEE; use IEEE.STD_LOGIC_1164.all;
use IEEE.NUMERIC_STD_UNSIGNED.all;
entity shifter is
  port(a:          in  STD_LOGIC_VECTOR(31 downto 0);
        shamt:     in  STD_LOGIC_VECTOR(4 downto 0);
        shtype:    in  STD_LOGIC_VECTOR(1 downto 0);
        y:         out STD_LOGIC_VECTOR(31 downto 0));
end;
architecture behave of shifter is
begin
  process (all) begin
    case shtype is
      when "10" => y <= TO_STDLOGICVECTOR(TO_BITVECTOR(a) sra
TO_INTEGER(shamt));

```

```

        when "11" => y <= ( (TO_STDLOGICVECTOR(TO_BITVECTOR(a) srl
TO_INTEGER(shamt))) or (TO_STDLOGICVECTOR(TO_BITVECTOR(a) sll (32-
TO_INTEGER(shamt)))) );
        when others => y <= a;
    end case;
end process;
end;

```

### Test ARM assembly

// If successful, it should write the value 0x2FFFFFFE to address 0x58

```

MAIN
    SUB R3, PC, PC           ; R3 = 0
    SUB R4, R3, #30         ; R4 = -30 (0xFFFFFFFFE2)
    ASR R5, R4, #1         ; R5 = -15 (0xFFFFFFFFF1)
    TST R4, R5             ; set flags based on R4 & R5: NZCV=1000
    ADDMIS R6, R4, R5      ; R6 = -30 + (-15)=-45 (0xFFFFFFFFD3) if N = 1
    (should happen)

                                ; also set flags: NZCV=1010
    SBCS R7, R5, R6        ; R7 = -15 - (-45) - 0 = 30 (0x1E)
                                ; also set flags: NZCV = 0010
    ADDS R3, R3, #25       ; R3 = 25, set flags: NZCV = 0000
    SBC R8, R7, R5         ; R8 = 30 - (-15) - 1 = 44 (0x2c)
    ROR R9, R4, #4        ; R9 = 0xFFFFFFFFE2 ROR 4 = 0x2FFFFFFE
    STR R9, [R8, #0x2c]    ; mem[0x30] <= 0x2FFFFFFE

;0x00 E04F300F SUB R3,PC,PC
;0x04 E243401E SUB R4,R3,#0x1E
;0x08 E1A050C4 ASR R5,R4,#1
;0x0C E1140005 TST R4,R5
;0x10 40946005 ADDMIS R6,R4,R5
;0x14 E0D57006 SBCS R7,R5,R6
;0x18 E2933019 ADDS R3,R3,#0x19
;0x1C E0C78005 SBC R8,R7,R5
;0x20 E1A09264 ROR R9,R4,#4
;0x24 E588902C STR R9,[R8,#0x2C

```

### ex7.27\_memfile.dat

```

E04F300F
E243401E
E1A050C4
E1140005
40946005
E0D57006
E2933019
E0C78005
E1A09264
E588902C

```

**Exercise 7.29**

In cycle 5, R0 is being written (by ADD) and registers R2 and R5 are being read (by ORR).

**Exercise 7.31**

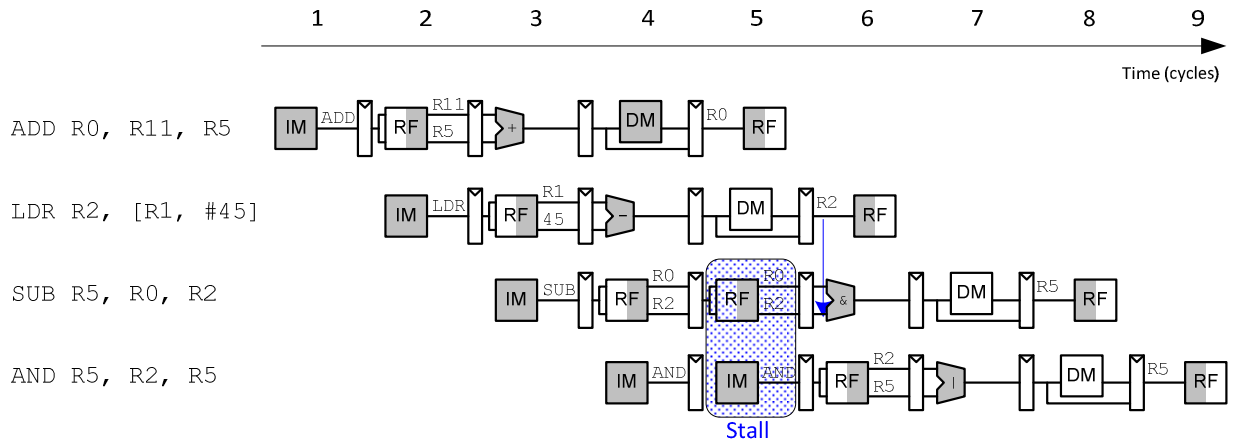

**Exercise 7.33**

**75 cycles** are required for the pipelined ARM processor to issue all of the instructions: 3 cycles for the first three MOV instructions, 7 cycles for each of the 10 loop iterations (5 for fetching instructions and 2 for the branch delay penalty), and 2 for the final CMP and BEQ that branches out of the loop.

The number of instructions fetched is  $3 + 10 \cdot 5 + 2 = 55$  instructions. Thus, CPI is  $75 \text{ c.c.} / 55 \text{ instr} = 1.36$ .

**Exercise 7.35**

Changes to the pipelined processor for the CMN instruction.

**ALU Decoder truth table**

ALUOp	Func <sub>t</sub> <sub>4:1</sub> (cmd)	Func <sub>t</sub> <sub>0</sub> (S)	Notes	ALUControl <sub>1:0</sub>	FlagW <sub>1:0</sub>	NoWrite
0	X	X	Not DP	00	00	0
1	0100	0	ADD	00	00	0
		1			11	0
	0010	0	SUB	01	00	0
		1			11	0
	0000	0	AND	10	00	0
		1			10	0

1100	0	ORR	11	00	0
	1			10	0
1011	1	CMN	00	11	1

**Datapath**

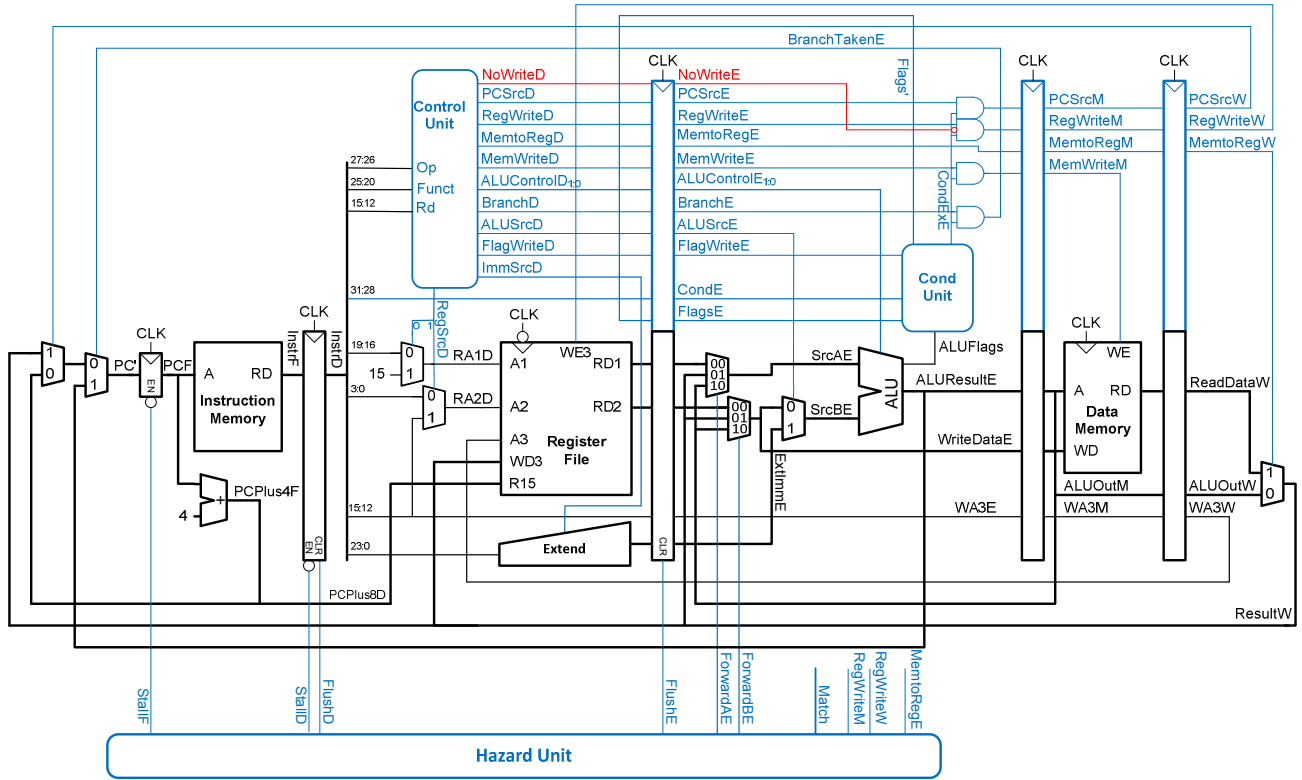

**Control**

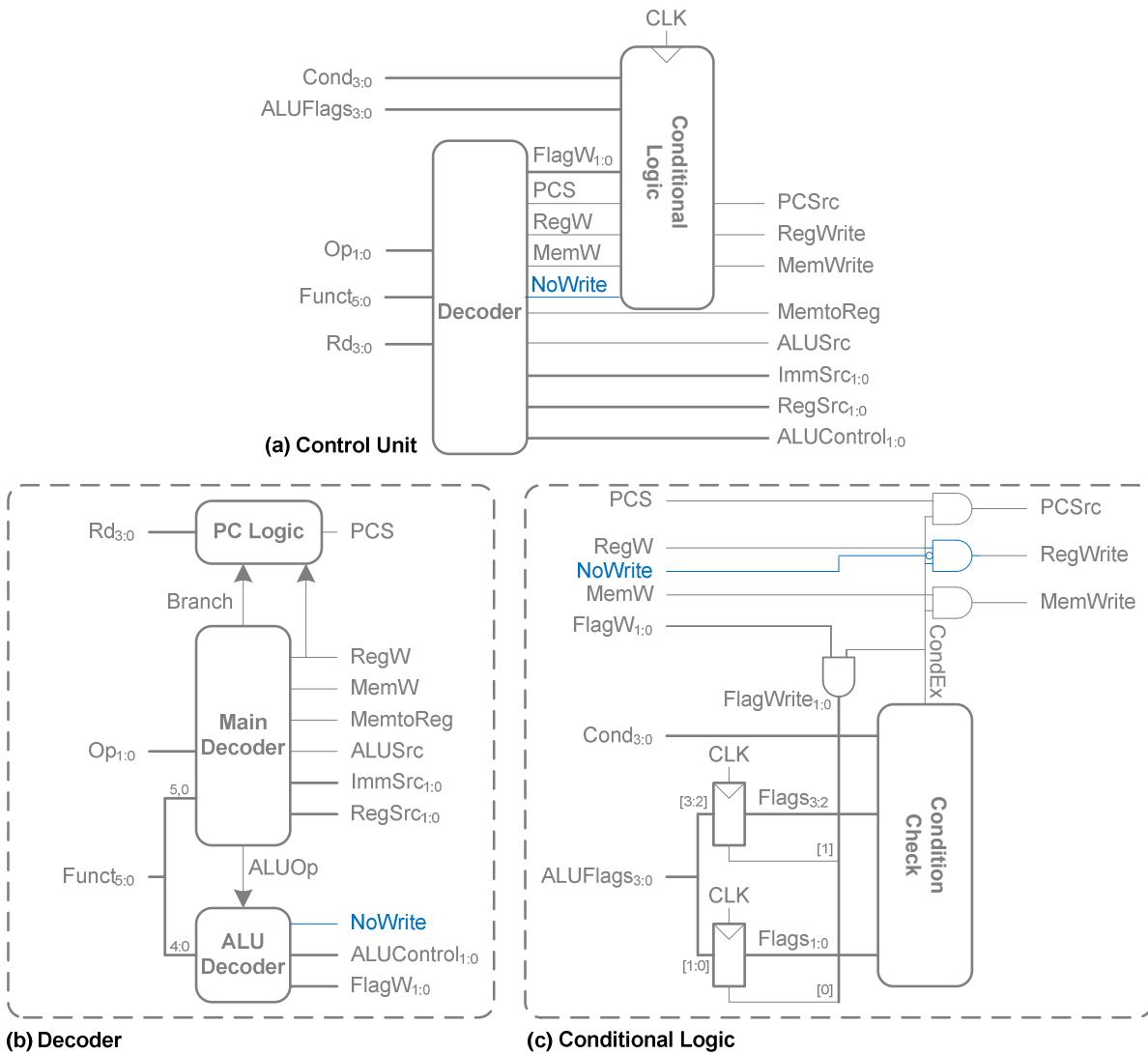

**Exercise 7.37**

She should work on the **register file** because it is the unit that's in the critical path (Decode stage) causing the cycle time ( $T_{c3}$ ) to be 300 ps. The next longest paths are 290 ps (for the Fetch stage and for the Memory stage). Reducing the register file read delay by 5 ps (to 95 ps) reduces the cycle time to 290 ps (see Equation 7.5). Reducing the delay any more would not improve performance any further. Thus,  $t_{RRead}$  should be reduced to **95 ps**, and the resulting cycle time,  $T_{c3}$ , is  $2(t_{RRead} + t_{setup}) = 2(95 + 50) \text{ ps} = \mathbf{290 \text{ ps}}$ .

**Exercise 7.39**

Suppose the ARM pipelined processor is divided into 10 stages of 400 ps each, including sequencing overhead. Assume the instruction mix of Example 7.7. Also assume that 50% of the loads are immediately followed by an instruction that uses the result, requiring six stalls, and that 30% of the branches are mispredicted. The target address of a branch instruction is not computed until the end of the second stage. Calculate the average CPI and execution time of computing 100 billion instructions from the SPECINT2000 benchmark for this 10-stage pipelined processor.

$$\text{CPI} = 0.25(1+0.5*6) + 0.1(1) + 0.13(1+0.3*1)+0.52(1) = 1.789 \approx \mathbf{1.8}$$

$$\text{Execution Time} = (100 \times 10^9 \text{ instructions})(1.789 \text{ cycles/instruction})(400 \times 10^{-12} \text{ s/cycle}) = 71.56 \text{ s} \\ \approx \mathbf{72 \text{ s}}$$

**Exercise 7.41****SystemVerilog**

```

module hazard(input  logic      clk, reset,
              input  logic      Match_1E_M, Match_1E_W, Match_2E_M,
              input  logic      Match_2E_W, Match_12D_E,
              input  logic      RegWriteM, RegWriteW,
              input  logic      BranchTakenE, MemtoRegE,
              input  logic      PCWrPendingF, PCSrcW,
              output logic [1:0] ForwardAE, ForwardBE,
              output logic      StallF, StallD,
              output logic      FlushD, FlushE);

    logic ldrStallD;

    // forwarding logic
    always_comb begin
        if (Match_1E_M & RegWriteM) ForwardAE = 2'b10;
        else if (Match_1E_W & RegWriteW) ForwardAE = 2'b01;
        else ForwardAE = 2'b00;

        if (Match_2E_M & RegWriteM) ForwardBE = 2'b10;
        else if (Match_2E_W & RegWriteW) ForwardBE = 2'b01;
        else ForwardBE = 2'b00;
    end

    // stalls and flushes
    // Load RAW
    // when an instruction reads a register loaded by the previous,
    // stall in the decode stage until it is ready
    // Branch hazard
    // When a branch is taken, flush the incorrectly fetched instrs
    // from decode and execute stages
    // PC Write Hazard

```

```
// When the PC might be written, stall all following instructions
// by stalling the fetch and flushing the decode stage
// when a stage stalls, stall all previous and flush next
```

```
assign ldrStallD = Match_12D_E & MemtoRegE;

assign StallD = ldrStallD;
assign StallF = ldrStallD | PCWrPendingF;
assign FlushE = ldrStallD | BranchTakenE;
assign FlushD = PCWrPendingF | PCSrcW | BranchTakenE;
```

```
endmodule
```

## VHDL

```
library IEEE; use IEEE.STD_LOGIC_1164.all;
entity hazard is
  port (clk, reset:          in  STD_LOGIC;
        Match_1E_M:         in  STD_LOGIC;
        Match_1E_W:         in  STD_LOGIC;
        Match_2E_M:         in  STD_LOGIC;
        Match_2E_W:         in  STD_LOGIC;
        Match_12D_E:        in  STD_LOGIC;
        RegWriteM:          in  STD_LOGIC;
        RegWriteW:          in  STD_LOGIC;
        BranchTakenE:       in  STD_LOGIC;
        MemtoRegE:          in  STD_LOGIC;
        PCWrPendingF:       in  STD_LOGIC;
        PCSrcW:             in  STD_LOGIC;
        ForwardAE:          out STD_LOGIC_VECTOR(1 downto 0);
        ForwardBE:          out STD_LOGIC_VECTOR(1 downto 0);
        StallF, StallD:     out STD_LOGIC;
        FlushD, FlushE:     out STD_LOGIC);
end;

architecture behave of hazard is
  signal ldrStallD: STD_LOGIC;
begin
  ForwardAE(1) <= '1' when (Match_1E_M and RegWriteM) else '0';
  ForwardAE(0) <= '1' when (Match_1E_W and RegWriteW and (not
    ForwardAE(1))) else '0';

  ForwardBE(1) <= '1' when (Match_2E_M and RegWriteM) else '0';
  ForwardBE(0) <= '1' when (Match_2E_W and RegWriteW and (not
    ForwardBE(1))) else '0';

  ldrStallD <= Match_12D_E and MemtoRegE;

  StallD <= ldrStallD;
  StallF <= ldrStallD or PCWrPendingF;
  FlushE <= ldrStallD or BranchTakenE;
  FlushD <= PCWrPendingF or PCSrcW or BranchTakenE;
end;
```

**Hazard Unit Schematic**

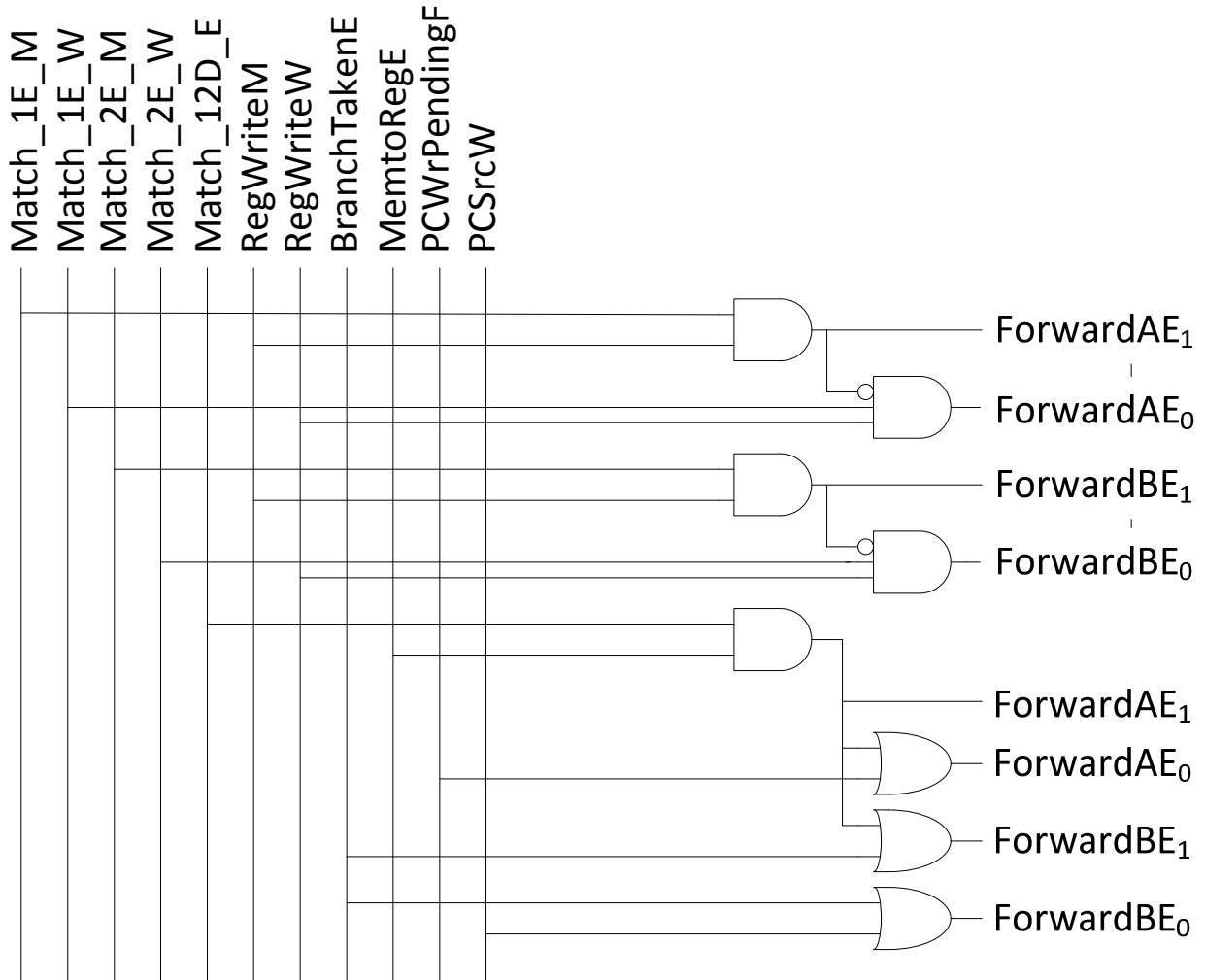

**Question 7.1**

A pipelined microprocessors with  $N$  stages offers an ideal speedup of  $N$  over nonpipelined microprocessor. This speedup comes at the cost of little extra hardware: pipeline registers and possibly a hazard unit. The disadvantage of a pipelined processor is added complexity, especially in dealing with data and control hazards.

**Question 7.3**

A hazard in a pipelined microprocessor occurs when the execution of an instruction depends on the result of a previously issued instruction that has not completed executing. Some options for dealing with hazards are:

- (1) to have the **compiler insert nops** to prevent dependencies,



**(2)** to have the **compiler reorder the code** to eliminate dependencies (inserting nops when this is impossible),

**(3)** to have the hardware **stall** (or **flush**) the pipeline when there is a dependency,

**(4)** to have the hardware **forward** results to earlier stages in the pipeline or stall when that is impossible.

**Options 1 and 2:** Advantages of the first two methods are that no added hardware is required, so area and, thus, cost and power is minimized. However, performance is not maximized in cases where nops are inserted.

**Option 3:** The advantage of having the hardware flush or stall the pipeline as needed is that the compiler can be simpler and, thus, likely faster to run and develop. Also, because there is no forwarding hardware, the added hardware is minimal. However, again, performance is not maximized in cases where forwarding could have been used instead of stalling.

**Option 4:** This option offers the greatest performance advantage but also costs the most hardware for forwarding, stalling, and flushing the pipeline as necessary because of dependencies.

**A combination of options 2 and 4** offers the greatest performance advantage at the cost of more hardware and a more sophisticated compiler.

# CHAPTER 8

## Exercise 8.1

---

Answers will vary.

**Temporal locality:** (1) making phone calls (if you called someone recently, you're likely to call them again soon). (2) using a textbook (if you used a textbook recently, you will likely use it again soon).

**Spatial locality:** (1) reading a magazine (if you looked at one page of the magazine, you're likely to look at next page soon). (2) walking to locations on campus - if a student is visiting a professor in the engineering department, she or he is likely to visit another professor in the engineering department soon.

## Exercise 8.3

---

Repeat data accesses to the following addresses:

0x0 0x10 0x20 0x30 0x40

The miss rate for the fully associative cache is: 100%. Miss rate for the direct-mapped cache is  $2/5 = 40\%$ .

## Exercise 8.5

---

(a) Increasing block size will increase the cache's ability to take advantage of spatial locality.

This will reduce the miss rate for applications with spatial locality. However, it also decreases the number of locations to map an address, possibly increasing conflict misses. Also, the miss penalty (the amount of time it takes to fetch the cache block from memory) increases.

(b) Increasing the associativity increases the amount of necessary hardware but in most cases decreases the miss rate. Associativities above 8 usually show only incremental decreases in miss rate.

(c) Increasing the cache size will decrease capacity misses and could decrease conflict misses. It could also, however, increase access time.

**Exercise 8.7**

---

(a) **False.**

Counterexample: A 2-word cache with block size of 1 word and access pattern:

0 4 8

This has a 50% miss rate with a direct-mapped cache, and a 100% miss rate with a 2-way set associative cache.

(b) **True.**

The 16KB cache is a superset of the 8KB cache. (Note: it's possible that they have the same miss rate.)

(c) **Usually true.**

Instruction memory accesses display great spatial locality, so a large block size reduces the miss rate.

**Exercise 8.9**

---

The figure below shows where each address maps for each cache configuration.

Set 15	7C		
	78		
	74		
	70		
	20		
Set 7	9C 1C	7C 9C 1C	78-7C
	98 18	78 98 18	70-74
	94 14	74 94 14	
	90 10	70 90 10	20-24
	4C 8C C	4C 8C C	98-9C 18-1C
	48 88 8	48 88 8	90-94 10-14
	44 84 4	44 84 4	48-4C 88-8C 8-C
Set 0	40 80 0	40 80 0 20	40-44 80-84 0-4

(a) Direct Mapped                      (c) 2-way assoc                      (d) direct mapped b=2

(a) **80% miss rate.** Addresses 70-7C and 20 use unique cache blocks and are not removed once placed into the cache. Miss rate is  $20/25 = 80\%$ .

(b) **100% miss rate.** A repeated sequence of length greater than the cache size produces no hits for a fully-associative cache using LRU.

(c) **100% miss rate.** The repeated sequence makes at least three accesses to each set during each pass. Using LRU replacement, each value must be replaced each pass through.

(d) **40% miss rate.** Data words from consecutive locations are stored in each cache block. The larger block size is advantageous since accesses in the given sequence are made primarily to consecutive word addresses. A block size of two cuts the number of block fetches in half since two words are obtained per block fetch. The address of the second word in the block will always hit in this type of scheme (e.g. address 44 of the 40-44 address pair). Thus, the second consecutive word accesses always hit: 44, 4C, 74, 7C, 84, 8C, 94, 9C, 4, C, 14, 1C. Tracing block accesses (see Figure 8.1) shows that three of the eight blocks (70-74, 78-7C, 20-24) also remain in memory. Thus, the hit rate is:  $15/25 = 60\%$  and miss rate is 40%.

**Exercise 8.11**

---

- (a) 128
- (b) 100%
- (c) ii

**Exercise 8.13**

---

(a)

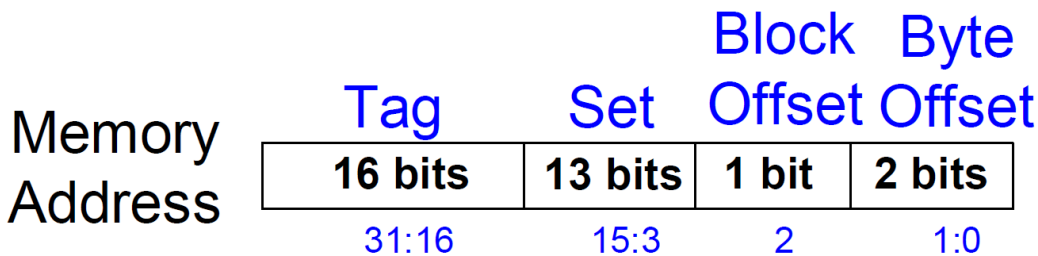

(b) Each tag is 16 bits. There are  $32\text{Kwords} / (2 \text{ words / block}) = 16\text{K}$  blocks and each block needs a tag:  $16 \times 16\text{K} = 218 = \mathbf{256 \text{ Kbits}}$  of tags.

(c) Each cache block requires: 2 status bits, 16 bits of tag, and 64 data bits, thus each set is  $2 \times 82 \text{ bits} = \mathbf{164 \text{ bits}}$ .

(d) See figure below. The design must use enough RAM chips to handle both the total capacity and the number of bits that must be read on each cycle. For the data, the SRAM must provide a capacity of 128 KB and must read 64 bits per cycle (one 32-bit word from each way). Thus the design needs at least  $128\text{KB} / (8\text{KB}/\text{RAM}) = 16 \text{ RAMs}$  to hold the data and  $64 \text{ bits} / (4 \text{ pins}/\text{RAM}) = 16 \text{ RAMs}$  to supply the number of bits. These are equal, so the design needs exactly 16 RAMs for the data.

For the tags, the total capacity is 32 KB, from which 32 bits (two 16-bit tags) must be read each cycle. Therefore, only 4 RAMs are necessary to meet the capacity, but 8 RAMs are needed to supply 32 bits per cycle. Therefore, the design will need 8 RAMs, each of which is being used at half capacity.

With 8K sets, the status bits require another  $8K \times 4\text{-bit}$  RAM. We use a  $16K \times 4\text{-bit}$  RAM, using only half of the entries.

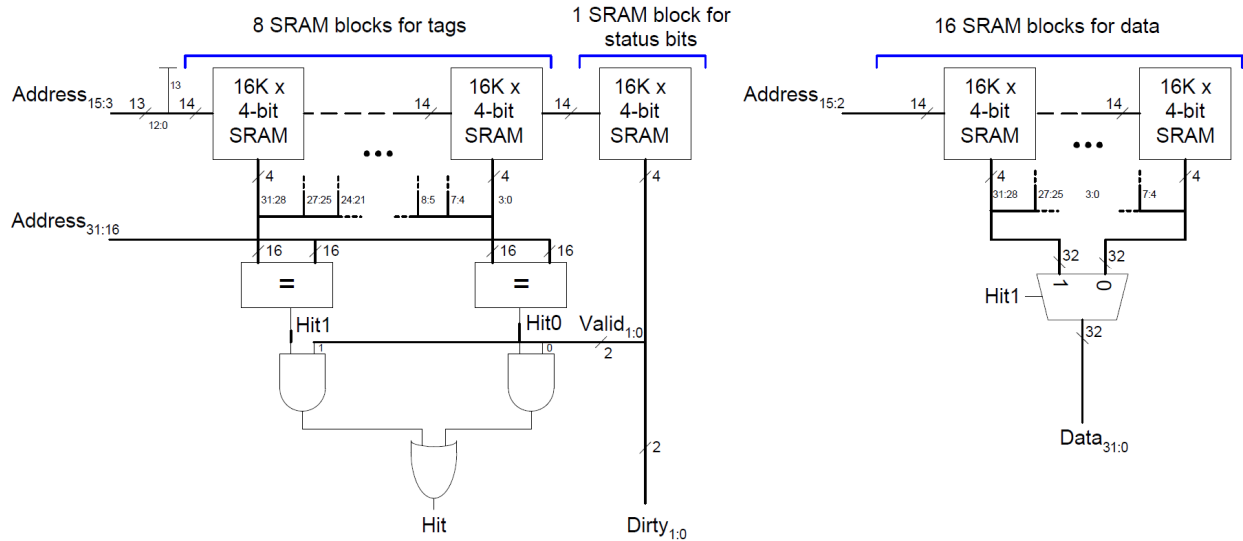

Bits 15:2 of the address select the word within a set and block. Bits 15-3 select the set. Bits 31:16 of the address are matched against the tags to find a hit in one (or none) of the two blocks with each set.

**Exercise 8.15**

(a) **FIFO:** FIFO replacement approximates LRU replacement by discarding data that has been in the cache longest (and is thus least likely to be used again). A FIFO cache can be stored as a queue, so the cache need not keep track of the least recently used way in an N-way set-associative cache. It simply loads a new cache block into the next way upon a new access. FIFO replacement doesn't work well when the least recently used data is not also the data fetched longest ago.

**Random:** Random replacement requires less overhead (storage and hardware to update status bits). However, a random replacement policy might randomly evict recently used data. In practice random replacement works quite well.

(b) FIFO replacement would work well for an application that accesses a first set of data, then the second set, then the first set again. It then accesses a third set of data and finally goes back to access the second set of data. In this case, FIFO would replace the first set with the third set, but LRU would replace the second set. The LRU replacement would require the cache to pull in the second set of data twice.

### Exercise 8.17

---

(a)  $AMAT = t_{\text{cache}} + MR_{\text{cache}} t_{\text{MM}}$

With a cycle time of  $1/1 \text{ GHz} = 1 \text{ ns}$ ,

$$AMAT = 1 \text{ ns} + 0.15(200 \text{ ns}) = \mathbf{31 \text{ ns}}$$

(b)  $CPI = 31 + 4 = \mathbf{35 \text{ cycles}}$  (for a load)  
 $CPI = 31 + 3 = \mathbf{34 \text{ cycles}}$  (for a store)

(c) Average CPI =  $(0.11 + 0.02)(3) + (0.52)(4) + (0.1)(34) + (0.25)(35) = \mathbf{14.6}$

(d) Average CPI =  $14.6 + 0.1(200) = \mathbf{34.6}$

### Exercise 8.19

---

From Figure 8.4, \$1 million will buy about  $(\$1 \text{ million} / (\$0.05/\text{GB})) = 20 \text{ million GB}$  of hard disk:

$$20 \text{ million GB} \approx 2^{25} \times 2^{30} \text{ bytes} = 2^{55} \text{ bytes} = 2^5 \text{ petabytes} = \mathbf{32 \text{ petabytes}}$$

\$1 million will buy about  $(\$1,000,000 / (\$7/\text{GB})) \approx 143,000 \text{ GB}$  of DRAM.

$$143,000 \text{ GB} \approx 2^7 \times 2^{10} \times 2^{30} = 2^{47} \text{ bytes} = 2^7 \text{ terabytes} = \mathbf{128 \text{ terabytes}}$$

Thus, the system would need **47 bits** for the physical address and **55 bits** for the virtual address.

### Exercise 8.21

---

(a) **31 bits**

(b)  $2^{50}/2^{12} = 2^{38}$  **virtual pages**

(c)  $2 \text{ GB} / 4 \text{ KB} = 2^{31}/2^{12} = 2^{19}$  **physical pages**

(d) virtual page number: **38 bits**; physical page number = **19 bits**

(e)  $2^{38}$  page table entries (one for each virtual page).

(f) Each entry uses 19 bits of physical page number and 2 bits of status information. Thus, **3 bytes** are needed for each entry (rounding 21 bits up to the nearest number of bytes).

(h) The total table size is  **$3 \times 2^{38}$  bytes**.

**Exercise 8.23**

(a) 1 valid bit + 19 data bits (PPN) + 38 tag bits (VPN) x 128 entries = 58 x 128 bits = **7424 bits**

(b)

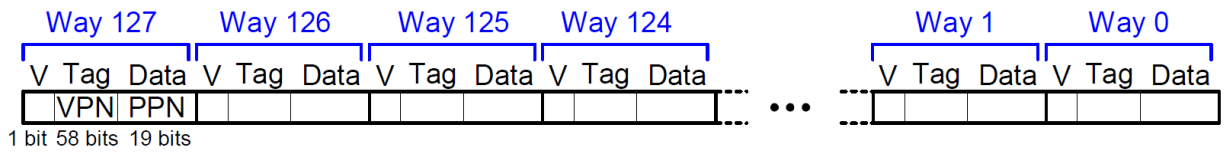

(c) 128 x 58-bit SRAM

**Exercise 8.25**

(a) Each entry in the page table has 2 status bits (V and D), and a physical page number (22-16 = 6 bits). The page table has  $2^{25-16} = 2^9$  entries.

Thus, the total page table size is  $2^9 \times 8$  bits = **4096 bits**

(b) This would increase the virtual page number to 25 - 14 = 11 bits, and the physical page number to 22 - 14 = 8 bits. This would increase the page table size to:

$$2^{11} \times 10 \text{ bits} = \mathbf{20480 \text{ bits}}$$

This increases the page table by 5 times, wasted valuable hardware to store the extra page table bits.

(c) Yes, this is possible. In order for concurrent access to take place, the number of set + block offset + byte offset bits must be less than the page offset bits.

(d) It is impossible to perform the tag comparison in the on-chip cache concurrently with the page table access because the upper (most significant) bits of the physical address are unknown until after the page table lookup (address translation) completes.

**Exercise 8.27**

(a)  $2^{32}$  bytes = 4 gigabytes

(b) The amount of the hard disk devoted to virtual memory determines how many applications can run and how much virtual memory can be devoted to each application.

(c) The amount of physical memory affects how many physical pages can be accessed at once. With a small main memory, if many applications run at once or a single application accesses

addresses from many different pages, thrashing can occur. This can make the applications dreadfully slow.

### Question 8.1

---

Caches are categorized based on the number of blocks ( $B$ ) in a set. In a direct-mapped cache, each set contains exactly one block, so the cache has  $S = B$  sets. Thus a particular main memory address maps to a unique block in the cache. In an  $N$ -way set associative cache, each set contains  $N$  blocks. The address still maps to a unique set, with  $S = B / N$  sets. But the data from that address can go in any of the  $N$  blocks in the set. A fully associative cache has only  $S = 1$  set. Data can go in any of the  $B$  blocks in the set. Hence, a fully associative cache is another name for a  $B$ -way set associative cache.

A **direct mapped cache** performs better than the other two when the data access pattern is to sequential cache blocks in memory with a repeat length one greater than the number of blocks in the cache.

An  **$N$ -way set-associative cache** performs better than the other two when  $N$  sequential block accesses map to the same set in the set-associative and direct-mapped caches. The last set has  $N+1$  blocks that map to it. This access pattern then repeats.

In the direct-mapped cache, the accesses to the same set conflict, causing a 100% miss rate. But in the set-associative cache all accesses (except the last one) don't conflict. Because the number of block accesses in the repeated pattern is one more than the number of blocks in the cache, the fully associative cache also has a 100% miss rate.

A **fully associative cache** performs better than the other two when the direct-mapped and set-associative accesses conflict and the fully associative accesses don't. Thus, the repeated pattern must access at most  $B$  blocks that map to conflicting sets in the direct and set-associative caches.

### Question 8.3

---

The advantages of using a virtual memory system are the illusion of a larger memory without the expense of expanding the physical memory, easy relocation of programs and data, and protection between concurrently running processes. The disadvantages are a more complex



memory system and the sacrifice of some physical and possibly virtual memory to store the page table.