







**Digital Design &
Computer Architecture**

Sarah Harris & David Harris

**Chapter 5:
Digital Building Blocks**

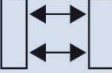
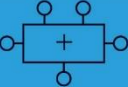
Chapter 5 :: Topics

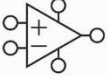
- **Introduction**
- **Arithmetic Circuits**
- **Number Systems**
- **Sequential Building Blocks**
- **Memory Arrays**
- **Logic Arrays**

Application Software	
Operating Systems	
Architecture	
Micro-architecture	
Logic	
Digital Circuits	
Analog Circuits	
Devices	
Physics	

Introduction

- **Digital building blocks:**
 - Gates, multiplexers, decoders, registers, arithmetic circuits, counters, memory arrays, logic arrays
- **Building blocks demonstrate hierarchy, modularity, and regularity:**
 - Hierarchy of simpler components
 - Well-defined interfaces and functions
 - Regular structure easily extends to different sizes
- **We'll use these building blocks in Chapter 7 to build a microprocessor**

Chapter 5: Digital Building Blocks

Adders

1-Bit Adders

Half Adder

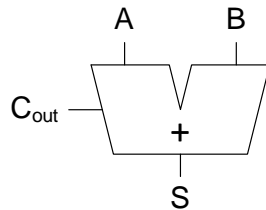

A	B	C_{out}	S
0	0		
0	1		
1	0		
1	1		

$$S = A \oplus B$$

$$C_{out} = A \cdot B$$

Full Adder

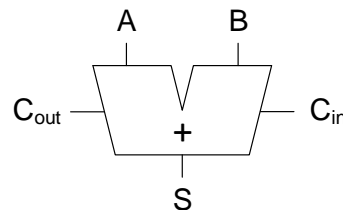

C_{in}	A	B	C_{out}	S
0	0	0		
0	0	1		
0	1	0		
0	1	1		
1	0	0		
1	0	1		
1	1	0		
1	1	1		

$$S = A \oplus B \oplus C_{in}$$

$$C_{out} = A \cdot B + C_{in} \cdot (A \oplus B)$$

Multibit Adders: CPAs

- Types of carry propagate adders (CPAs):
 - **Ripple-carry** (slow)
 - **Carry-lookahead** (fast)
 - **Prefix** (faster)
- Carry-lookahead and prefix adders faster for large adders but require more hardware

Symbol

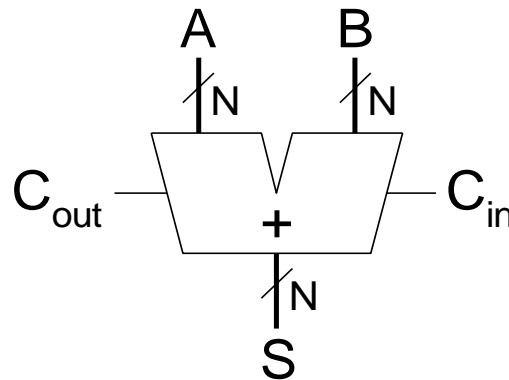

Chapter 5: Digital Building Blocks

Ripple Carry Addition

Ripple-Carry Adder

- Chain 1-bit adders together
- Carry ripples through entire chain
- Disadvantage: **slow**

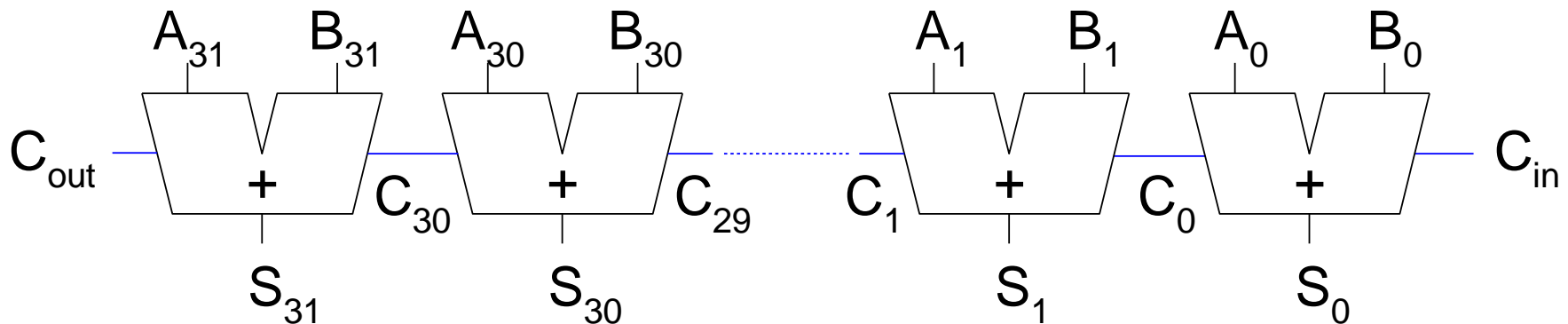

Ripple-Carry Adder Delay

$$t_{\text{ripple}} =$$

where t_{FA} is the delay of a 1-bit full adder

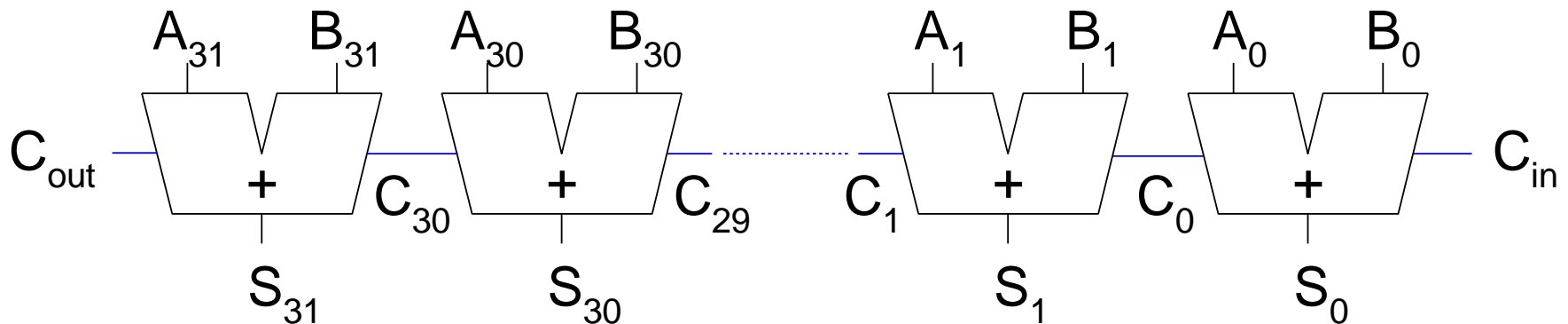

Chapter 5: Digital Building Blocks

Carry Lookahead Addition

Carry-Lookahead Adder

Compute C_{out} for k -bit blocks using *generate* and *propagate* signals

Some definitions:

- Column i produces a carry out by either **generating** a carry out or **propagating** a carry in to the carry out
- Calculate generate (G_i) and propagate (P_i) signals for each column:
 - **Generate:** Column i will generate a carry out if A_i and B_i are both 1.

$$G_i = A_i B_i$$

- **Propagate:** Column i will propagate a carry in to the carry out if A_i or B_i is 1.

$$P_i = A_i + B_i$$

- **Carry out:** The carry out of column i (C_i) is:

$$C_i = A_i B_i + (A_i + B_i) C_{i-1} = G_i + P_i C_{i-1}$$

Propagate and Generate Signals

Examples: Column propagate and generate signals:

Column propagate: $P_i = A_i + B_i$

Column generate: $G_i = A_i B_i$

$$\begin{array}{r} 1011 \\ + 0110 \\ \hline \end{array} \quad \begin{array}{l} A_{3:0} \\ B_{3:0} \end{array}$$

$$\begin{array}{r} 1011 \\ + 1001 \\ \hline \end{array} \quad \begin{array}{l} A_{3:0} \\ B_{3:0} \end{array}$$

Block Propagate and Generate

Now use column Propagate and Generate signals to compute **Block Propagate** and **Block Generate** signals for k-bit blocks, i.e.:

- Compute if a **k-bit group** will **propagate** a carry in (of the block) to the carry out (of the block)
- Compute if a **k-bit group** will **generate** a carry out (of the block)

Block Propagate and Generate

- **Example: 4-bit blocks**

- **Block propagate signal: $P_{3:0}$** (single-bit signal)

- A carry-in would propagate through all 4 bits of the block:

$$P_{3:0} = P_3 P_2 P_1 P_0$$

- **Examples:**

$$\begin{array}{r} 1011 \\ + 0100 \\ \hline \end{array}$$

$$\begin{array}{r} 1011 \\ + 0001 \\ \hline \end{array}$$

Block Propagate and Generate

- **Example: 4-bit blocks**

- **Block propagate signal: $P_{3:0}$** (single-bit signal)

- A carry-in would propagate through all 4 bits of the block:

$$P_{3:0} = P_3 P_2 P_1 P_0$$

- **Block generate signal: $G_{3:0}$** (single-bit signal)

- A carry is generated:

- in column 3, **or**
- in column 2 and propagated through column 3, **or**
- in column 1 and propagated through columns 2 and 3, **or**
- in column 0 and propagated through columns 1-3

$$G_{3:0} = G_3 + G_2 P_3 + G_1 P_2 P_3 + G_0 P_1 P_2 P_3$$

$$G_{3:0} = G_3 + P_3 [G_2 + P_2 (G_1 + P_1 G_0)]$$

Block Propagate and Generate

- **Example: 4-bit blocks**

- **Block generate signal: $G_{3:0}$** (single-bit signal)

- A carry is: generated in column 3, **or** generated in column 2 and propagated through column 3, **or** ...

$$G_{3:0} = G_3 + G_2P_3 + G_1P_2P_3 + G_0P_1P_2P_3$$

$$\begin{array}{r} 1001 \\ + 1100 \\ \hline \end{array}$$

$$\begin{array}{r} 1110 \\ + 0100 \\ \hline \end{array}$$

$$\begin{array}{r} 0110 \\ + 0010 \\ \hline \end{array}$$

Block Propagate and Generate

- **Example: 4-bit blocks**

- **Block propagate signal: $P_{3:0}$** (single-bit signal)

- A carry-in would propagate through all 4 bits of the block:

$$P_{3:0} = P_3 P_2 P_1 P_0$$

- **Block generate signal: $G_{3:0}$** (single-bit signal)

- A carry is generated:

- in column 3, **or**
- in column 2 and propagated through column 3, **or**
- in column 1 and propagated through columns 2 and 3, **or**
- in column 0 and propagated through columns 1-3

$$G_{3:0} = G_3 + G_2 P_3 + G_1 P_2 P_3 + G_0 P_1 P_2 P_3$$

$$G_{3:0} = G_3 + P_3 [G_2 + P_2 (G_1 + P_1 G_0)]$$

$$C_3 = G_{3:0} + P_{3:0} C_{-1}$$

Block Propagate and Generate

- **Example:** Block propagate and generate signals for 4-bit blocks ($P_{3:0}$ and $G_{3:0}$):

$$P_{3:0} = P_3 P_2 P_1 P_0$$

$$G_{3:0} = G_3 + P_3 (G_2 + P_2 (G_1 + P_1 G_0))$$

$$C_3 = G_{3:0} + P_{3:0} C_{-1}$$

32-bit CLA with 4-bit Blocks

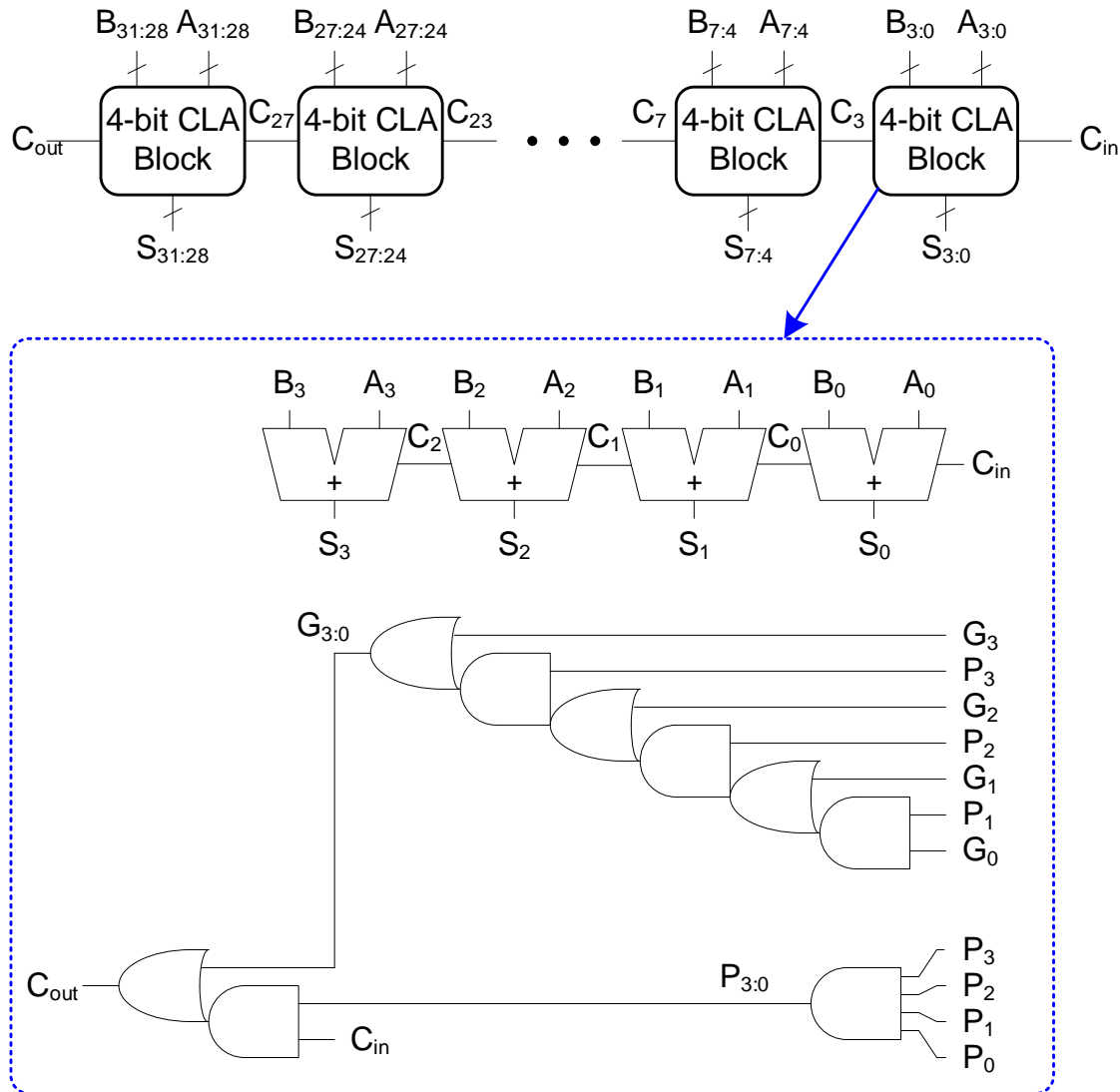

Carry-Lookahead Addition

- **Step 1:** Compute G_i and P_i for all columns
- **Step 2:** Compute G and P for k -bit blocks
- **Step 3:** C_{in} propagates through each k -bit propagate/generate logic (meanwhile computing sums)
- **Step 4:** Compute sum for most significant k -bit block

Carry-Lookahead Addition

- **Step 1:** Compute G_i and P_i for all columns

$$G_i = A_i B_i$$

$$P_i = A_i + B_i$$

Carry-Lookahead Addition

- **Step 1:** Compute G_i and P_i for all columns
- **Step 2:** Compute G and P for k -bit blocks

$$P_{3:0} = P_3 P_2 P_1 P_0$$

$$G_{3:0} = G_3 + P_3 (G_2 + P_2 (G_1 + P_1 G_0))$$

Carry-Lookahead Addition

- **Step 1:** Compute G_i and P_i for all columns
- **Step 2:** Compute G and P for k -bit blocks
- **Step 3:** C_{in} propagates through each k -bit propagate/generate logic (meanwhile computing sums)

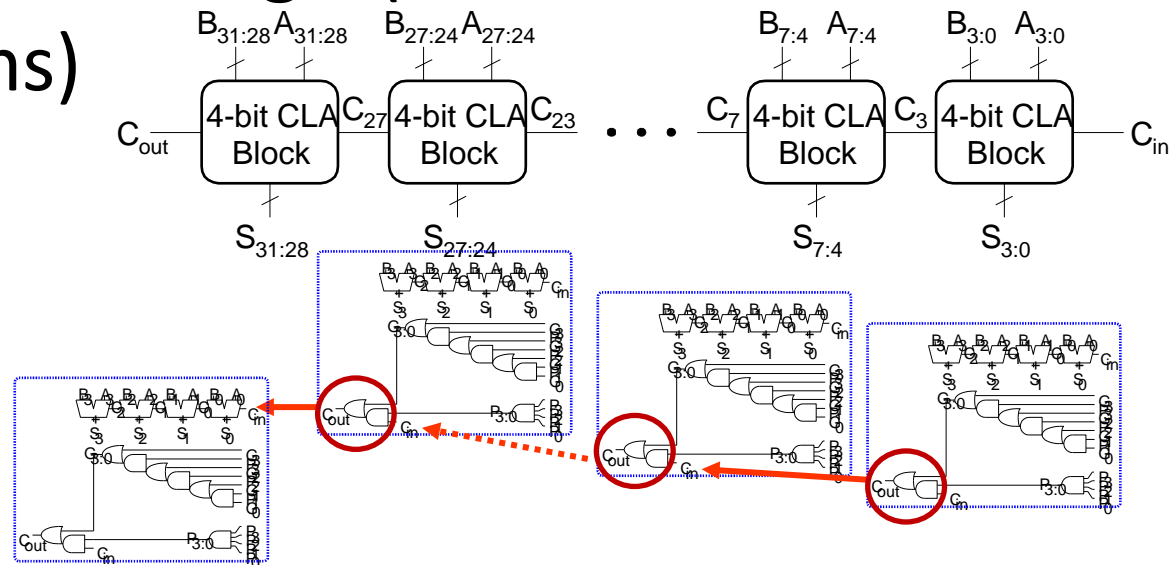

Carry-Lookahead Addition

- **Step 1:** Compute G_i and P_i for all columns
- **Step 2:** Compute G and P for k -bit blocks
- **Step 3:** C_{in} propagates through each k -bit propagate/generate logic (meanwhile computing sums)
- **Step 4:** Compute sum for most significant k -bit block

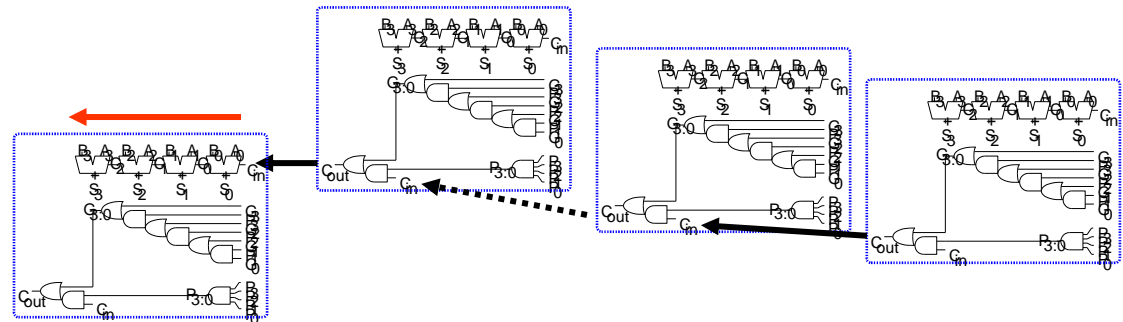

32-bit CLA with 4-bit Blocks

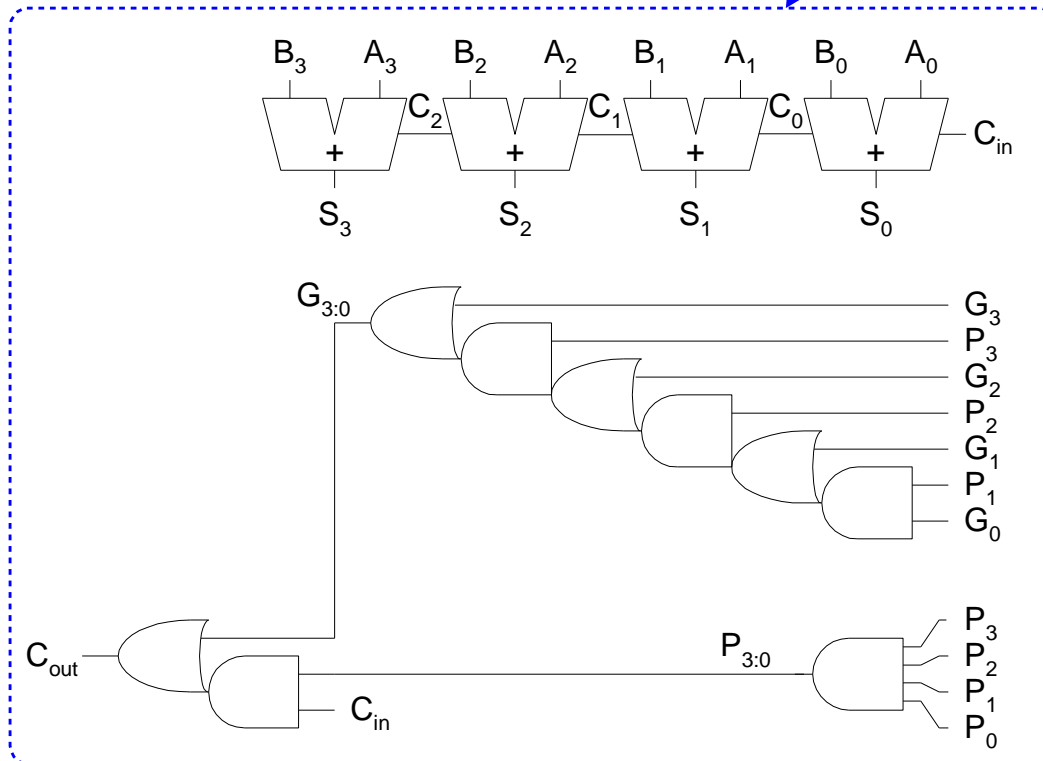
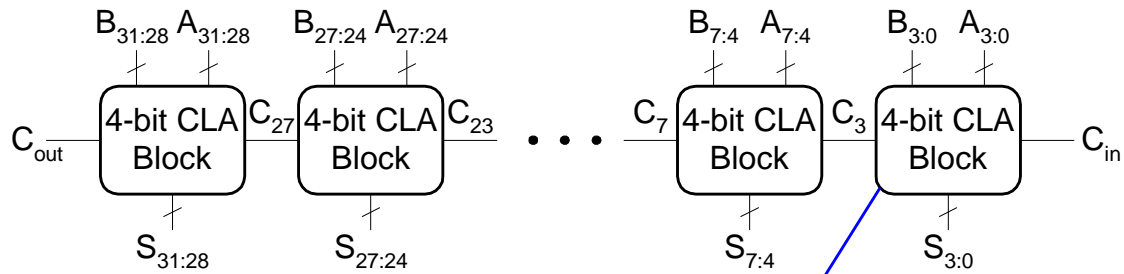

Carry-Lookahead Adder Delay

For N -bit CLA with k -bit blocks:

$$t_{CLA} = t_{pg} + t_{pg_block} + (N/k - 1)t_{AND_OR} + kt_{FA}$$

- t_{pg} : delay to generate all P_i, G_i
- t_{pg_block} : delay to generate all $P_{i:j}, G_{i:j}$
- t_{AND_OR} : delay from C_{in} to C_{out} of final AND/OR gate in k -bit CLA block

An N -bit carry-lookahead adder is generally much faster than a ripple-carry adder for $N > 16$

Chapter 5: Digital Building Blocks

Prefix

Addition

Prefix Adder

- Computes carry in (C_{i-1}) for each column, then computes sum:

$$S_i = (A_i \oplus B_i) \oplus C_{i-1}$$

- It computes C_{i-1} by:
 - Computing G and P for 1-, 2-, 4-, 8-bit blocks, etc. until all G_i (carry in) known
 - $G_i = C_i$
- $\log_2 N$ stages

Prefix Adder

- Carry out either *generated* in a column or *propagated* from a previous column.
- Column -1 holds C_{in} , so

$$G_{-1} = C_{in}, P_{-1} = X \text{ (not used)}$$

- Carry in to column i = carry out of column $i-1$:

$$C_{i-1} = G_{i-1:-1}$$

$G_{i-1:-1}$: generate signal spanning columns $i-1$ to -1

- Sum equation:

$$S_i = (A_i \oplus B_i) \oplus G_{i-1:-1}$$

- **Goal:** Quickly compute $G_{0:-1}, G_{1:-1}, G_{2:-1}, G_{3:-1}, G_{4:-1}, G_{5:-1}, \dots$
(called *prefixes*) (= $C_0, C_1, C_2, C_3, C_4, C_5, \dots$)

Prefix Adder

- Generate and propagate signals for a block spanning bits $i:j$

$$G_{i:j} = G_{i:k} + P_{i:k} G_{k-1:j}$$

$$P_{i:j} = P_{i:k} P_{k-1:j}$$

- In words:
 - **Generate:** block $i:j$ will generate a carry if:
 - **upper part** ($i:k$) generates a carry ($G_{i:k}$) **or**
 - upper part ($i:k$) propagates a carry ($P_{i:k}$) generated in lower part ($k-1:j$) ($G_{k-1:j}$)
 - **Propagate:** block $i:j$ will propagate a carry if *both* the upper and lower parts propagate the carry ($P_{i:k}$ **AND** $P_{k-1:j}$)

Prefix Adder Example

Step 1. Calculate P's and G's for **1-bit block**

Step 2. Calculate P's and G's for **2-bit blocks**

Step 3. Calculate P's and G's for **4-bit blocks**

Step 4. Continue to calculate P's and G's for larger blocks (8-bit, 16-bit, etc.)

Step 5. Use prefixes to calculate sums

Prefix Adder Schematic

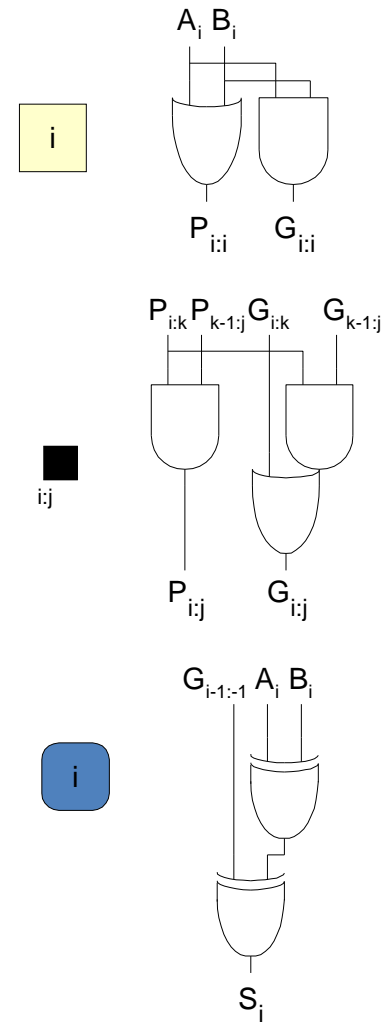
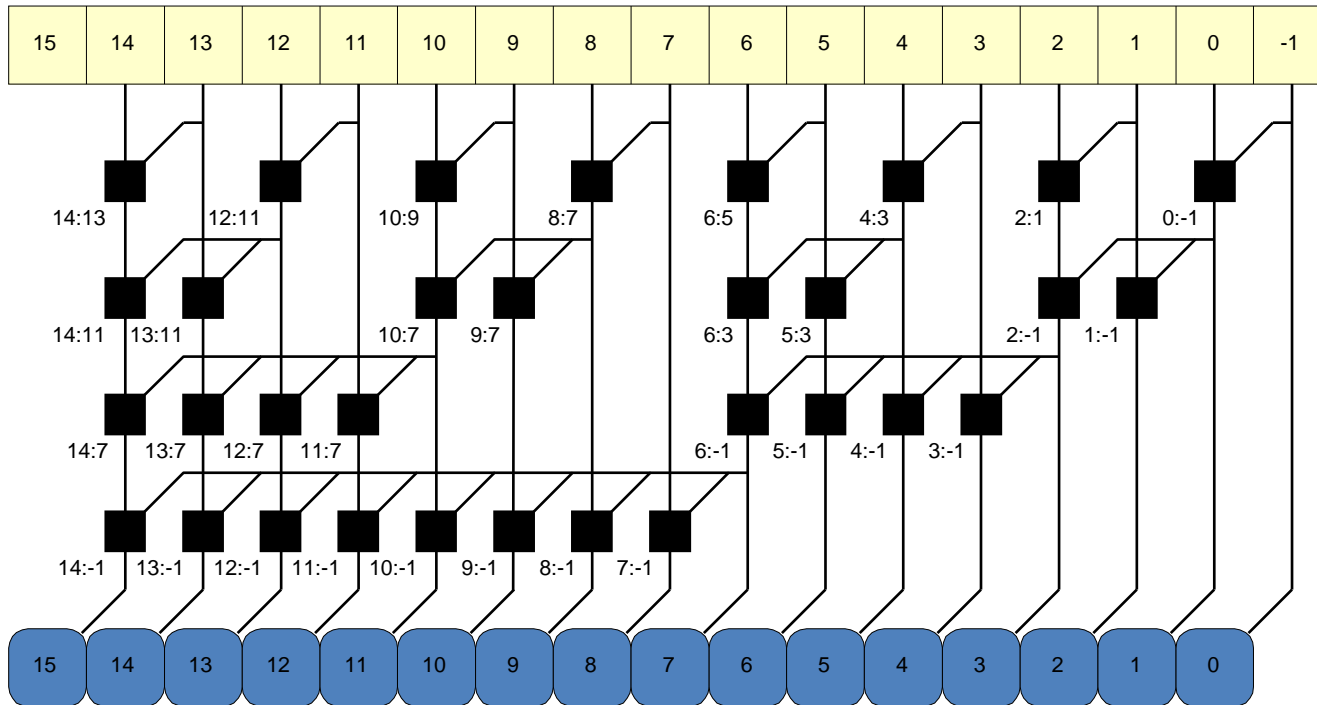

Prefix Adder Delay

$$t_{PA} = t_{pg} + \log_2 N (t_{pg_prefix}) + t_{XOR}$$

t_{pg} : delay to produce P_i, G_i (AND or OR gate)

t_{pg_prefix} : delay of black prefix cell (AND-OR gate)

Adder Delay Comparisons

Compare the delay of: 32-bit ripple-carry, CLA, and prefix adders

- CLA has 4-bit blocks
- 2-input gate delay = 100 ps; full adder delay = 300 ps

t_{ripple}

t_{CLA}

t_{PA}

Chapter 5: Digital Building Blocks

Subtractors & Comparators

Subtractor

$$A - B = A + \bar{B} + 1$$

Symbol

Implementation

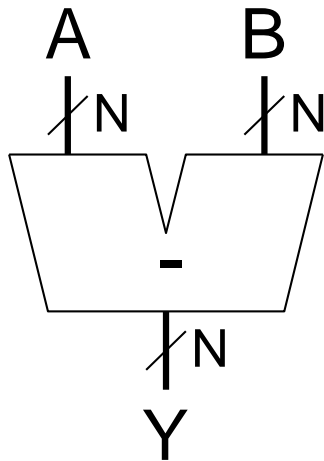

Comparator: Equality

Symbol

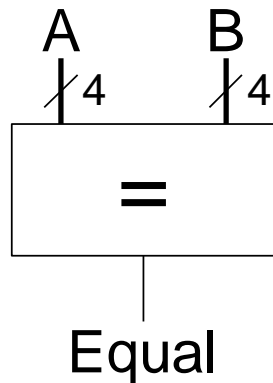

Implementation

Comparator: Signed Less Than

$A < B$ if $A - B$ is negative

Beware of overflow

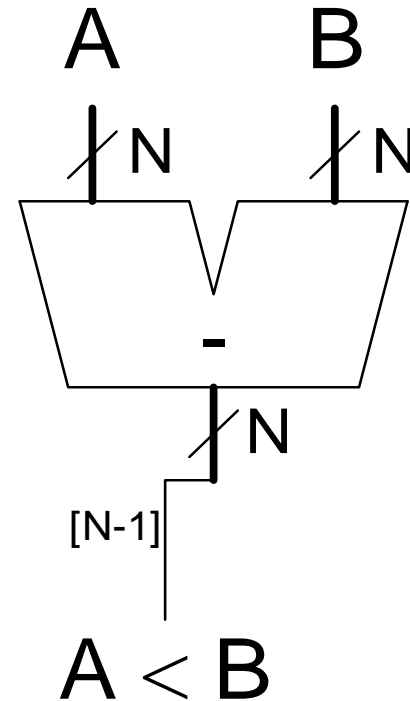

Chapter 5: Digital Building Blocks

ALU:

Arithmetic Logic Unit

ALU: Arithmetic Logic Unit

ALU should perform:

- Addition
- Subtraction
- AND
- OR

ALU: Arithmetic Logic Unit

ALUControl _{1:0}	Function
00	Add
01	Subtract
10	AND
11	OR

Example: Perform A OR B

$ALUControl_{1:0} = 11$

Result = A OR B

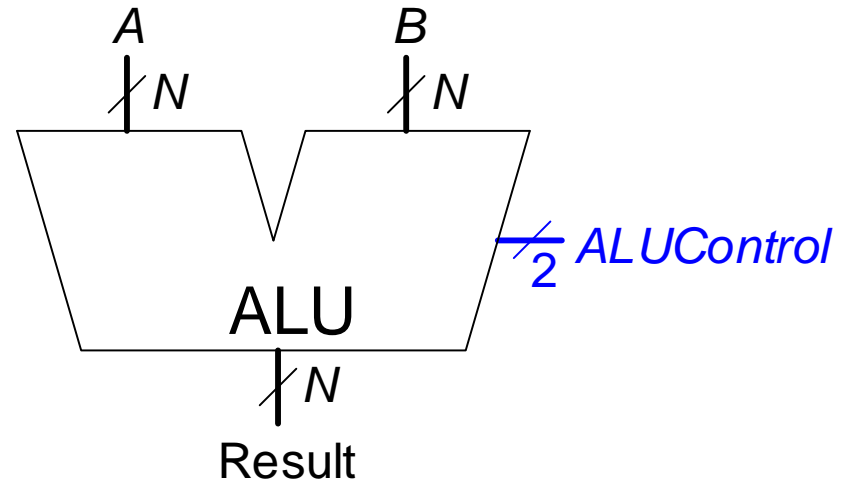

ALU: Arithmetic Logic Unit

ALUControl _{1:0}	Function
00	Add
01	Subtract
10	AND
11	OR

Example: Perform A OR B

$ALUControl_{1:0} = 11$

Mux selects output of OR gate as *Result*,

so:

$$Result = A OR B$$

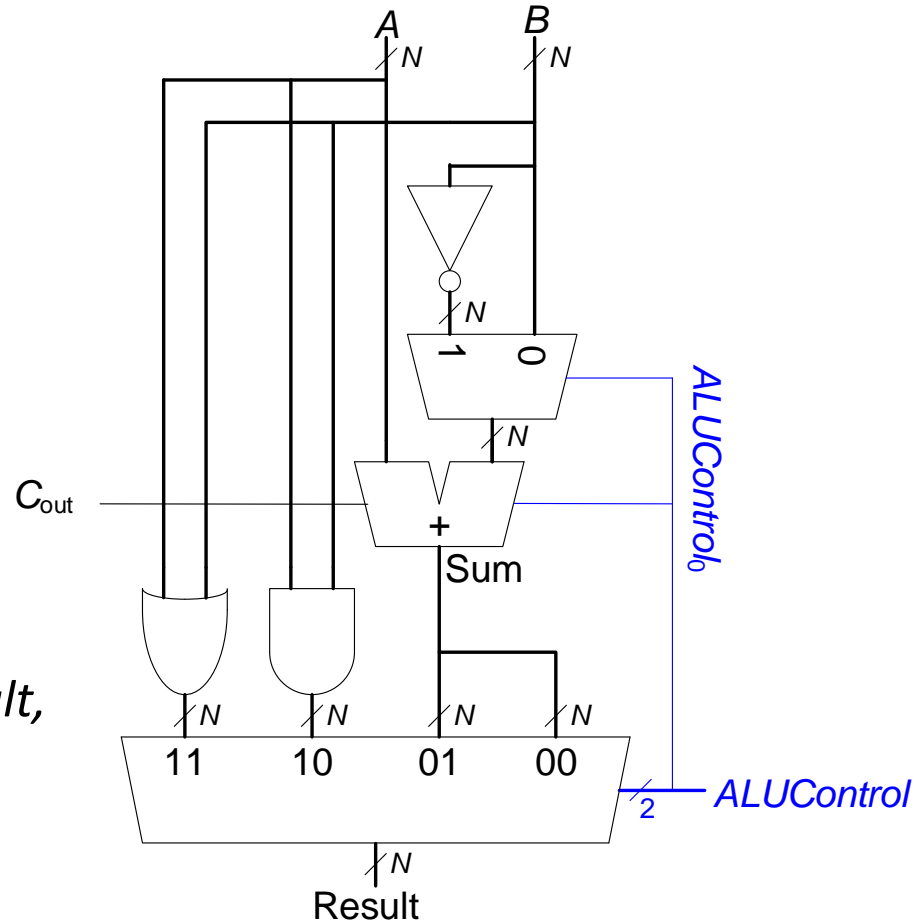

ALU: Arithmetic Logic Unit

ALUControl _{1:0}	Function
00	Add
01	Subtract
10	AND
11	OR

Example: Perform $A + B$

$ALUControl_{1:0} = 00$

$ALUControl_0 = 0$, so:

C_{in} to adder = 0

2nd input to adder is B

Mux selects *Sum* as *Result*, so

Result = $A + B$

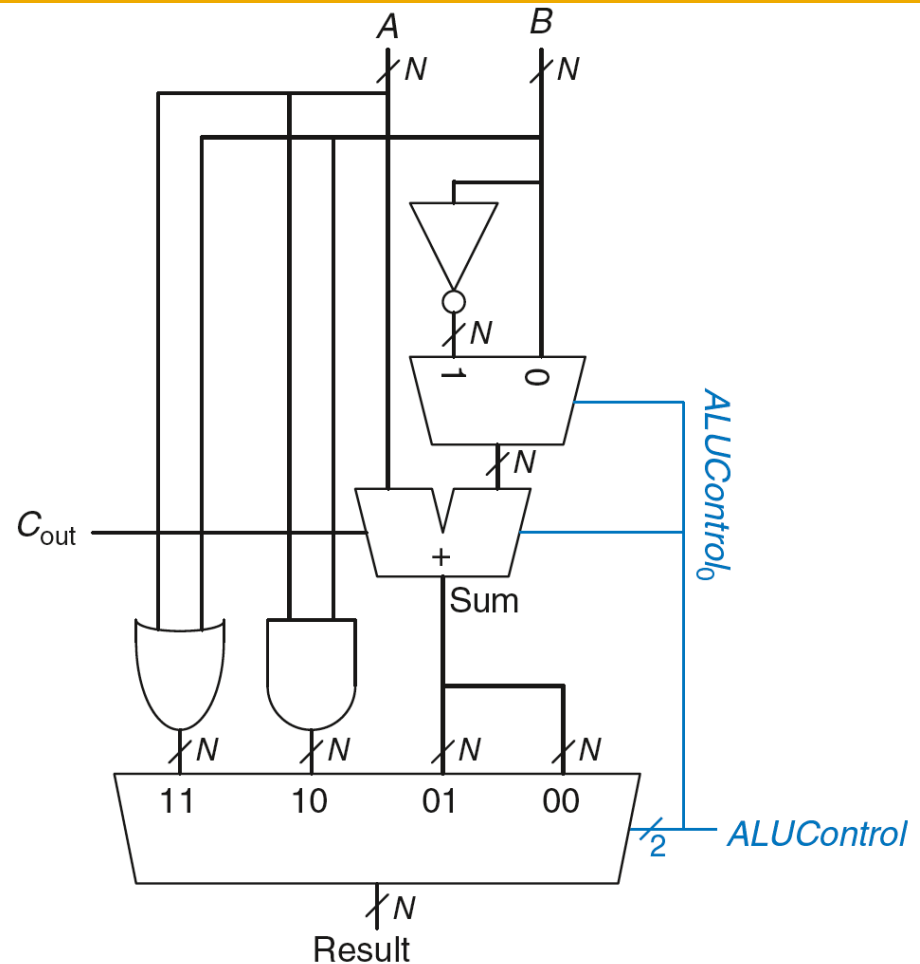

ALU with Status Flags

Flag	Description
<i>N</i>	Result is N egative
<i>Z</i>	Result is Z ero
<i>C</i>	Adder produces C arry out
<i>V</i>	Adder o verflowed

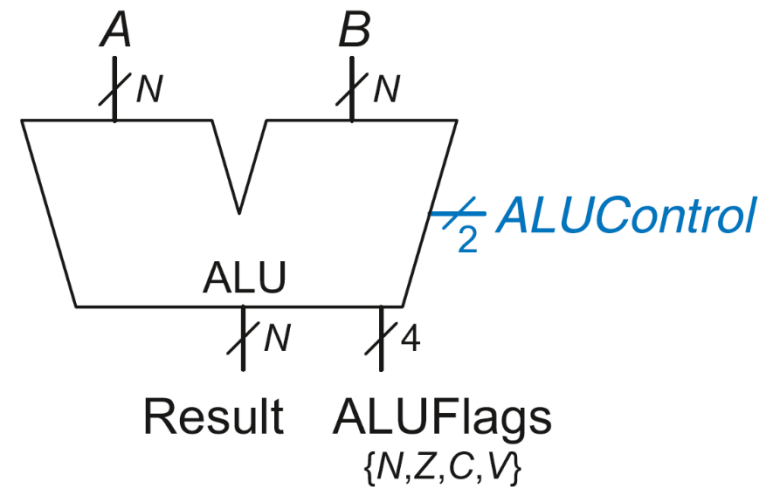

ALU with Status Flags

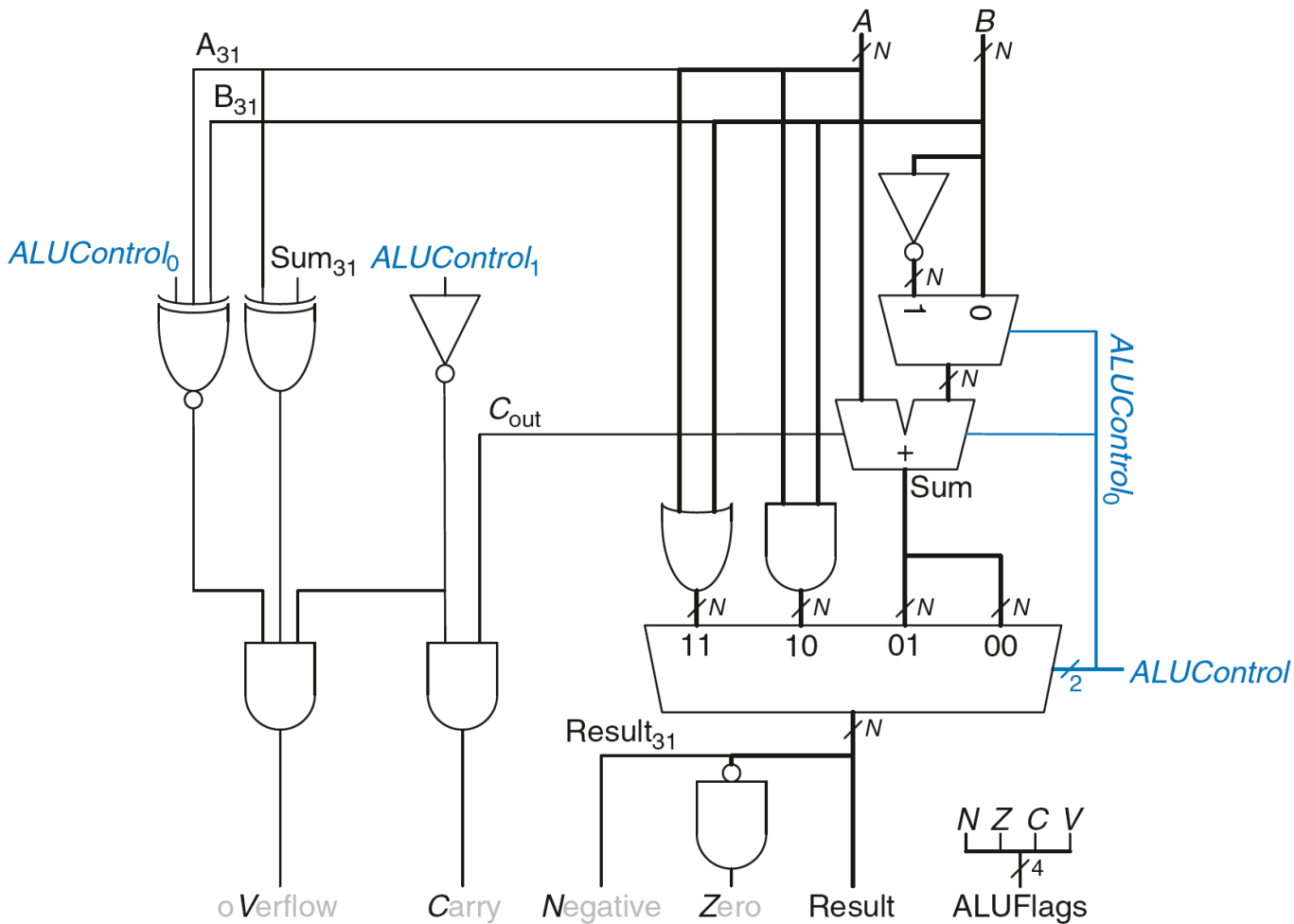

ALU with Status Flags: **N**egative

N = 1 if:

Result is negative

So, N is connected to most significant bit of *Result*.

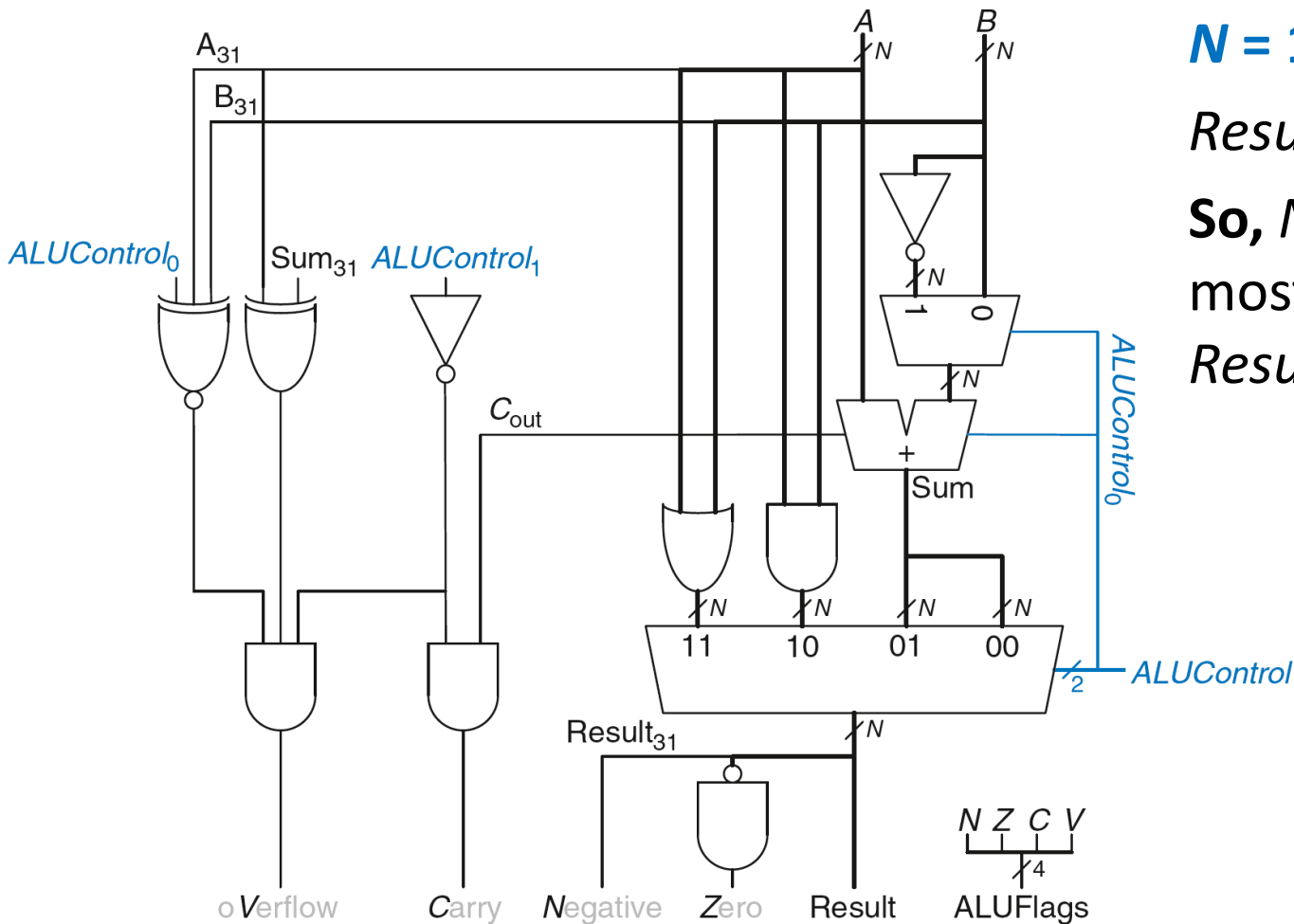

ALU with Status Flags: **Z**ero

Z = 1 if:

all of the bits of *Result*
are 0

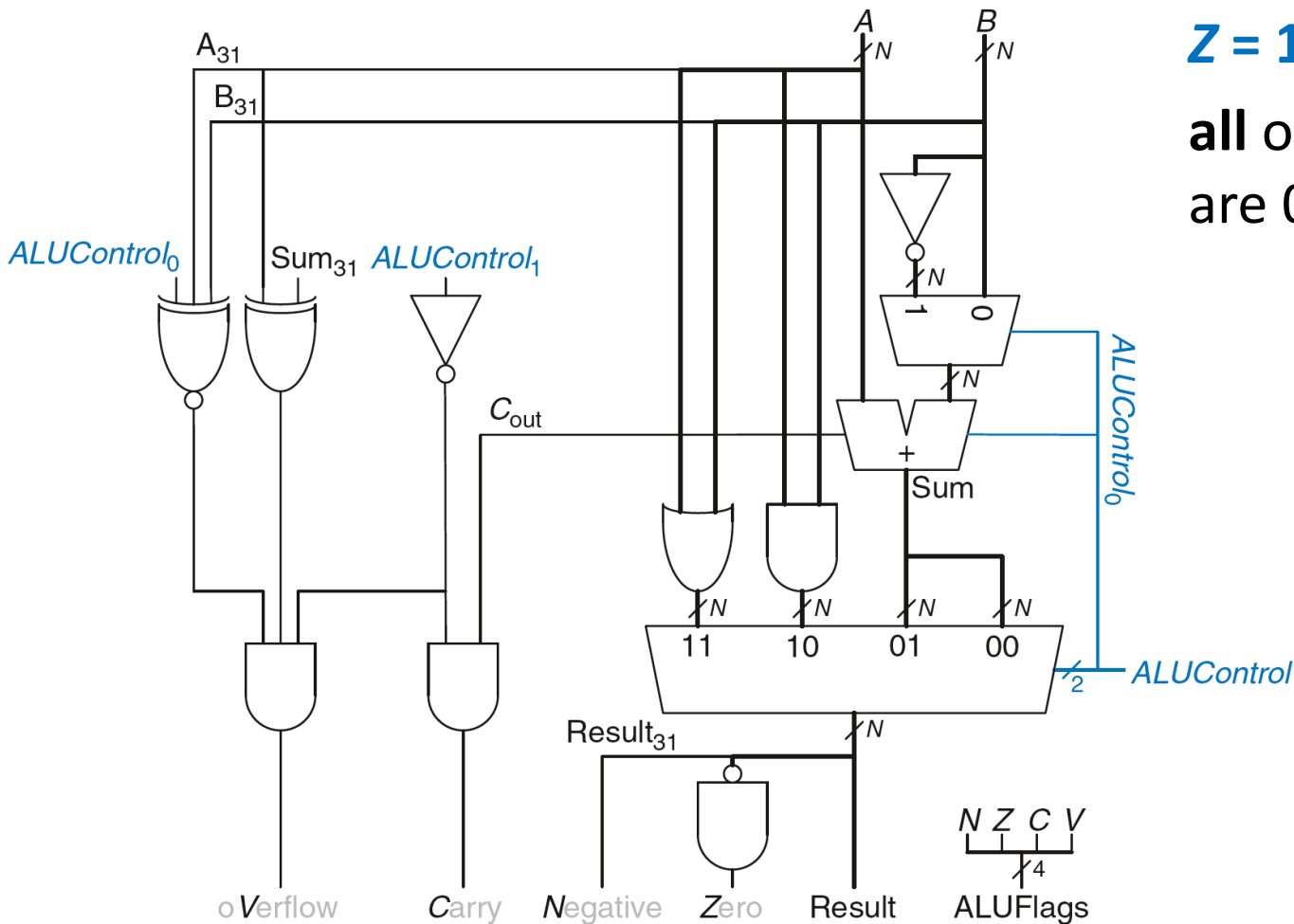

ALU with Status Flags: Carry

$C = 1$ if:

C_{out} of Adder is 1

AND

ALU is adding or subtracting (ALUControl is 00 or 01)

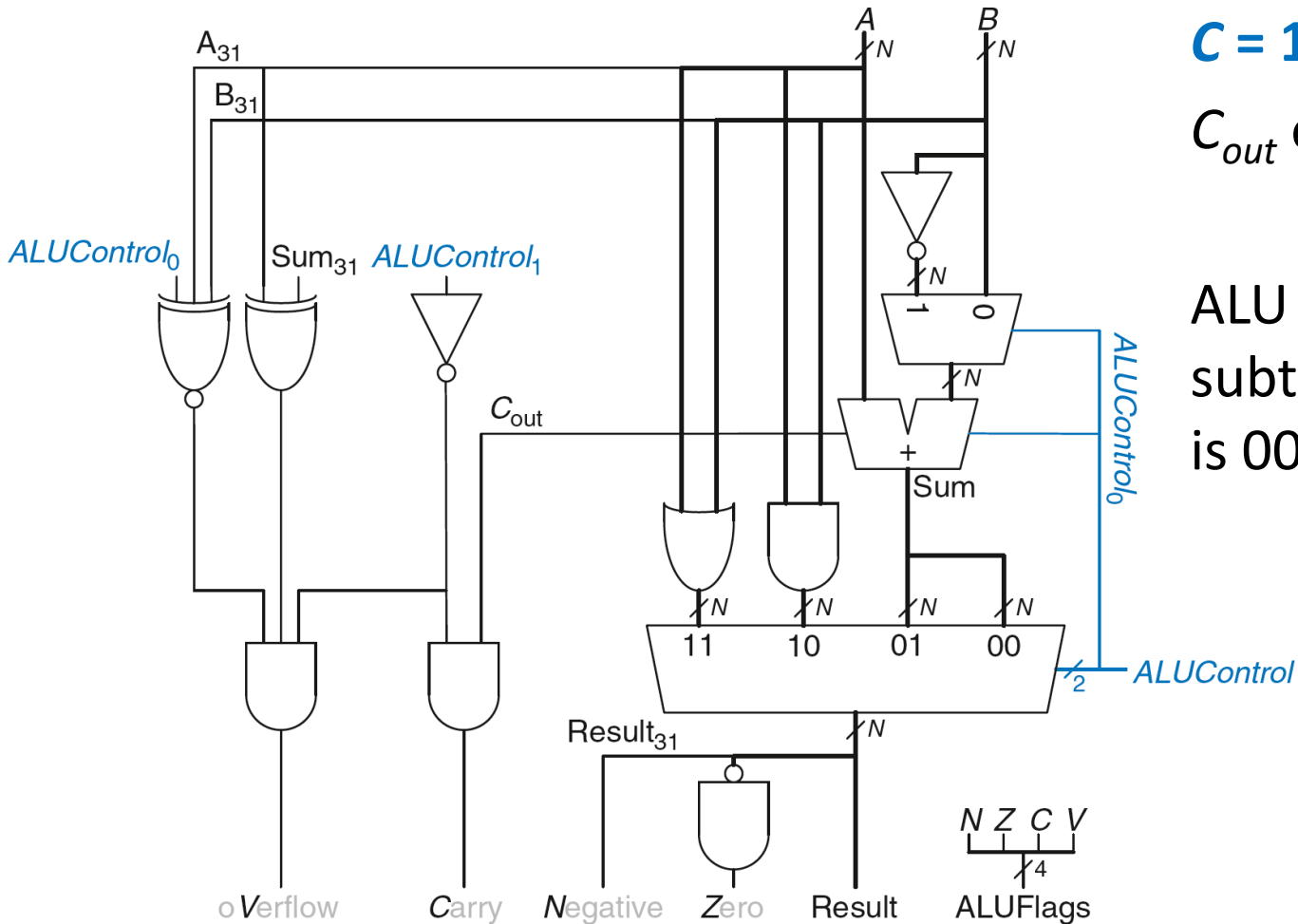

ALU with Status Flags: oVerflow

$V = 1$ if:

The addition of 2 **same-signed numbers** produces a result with the **opposite sign**

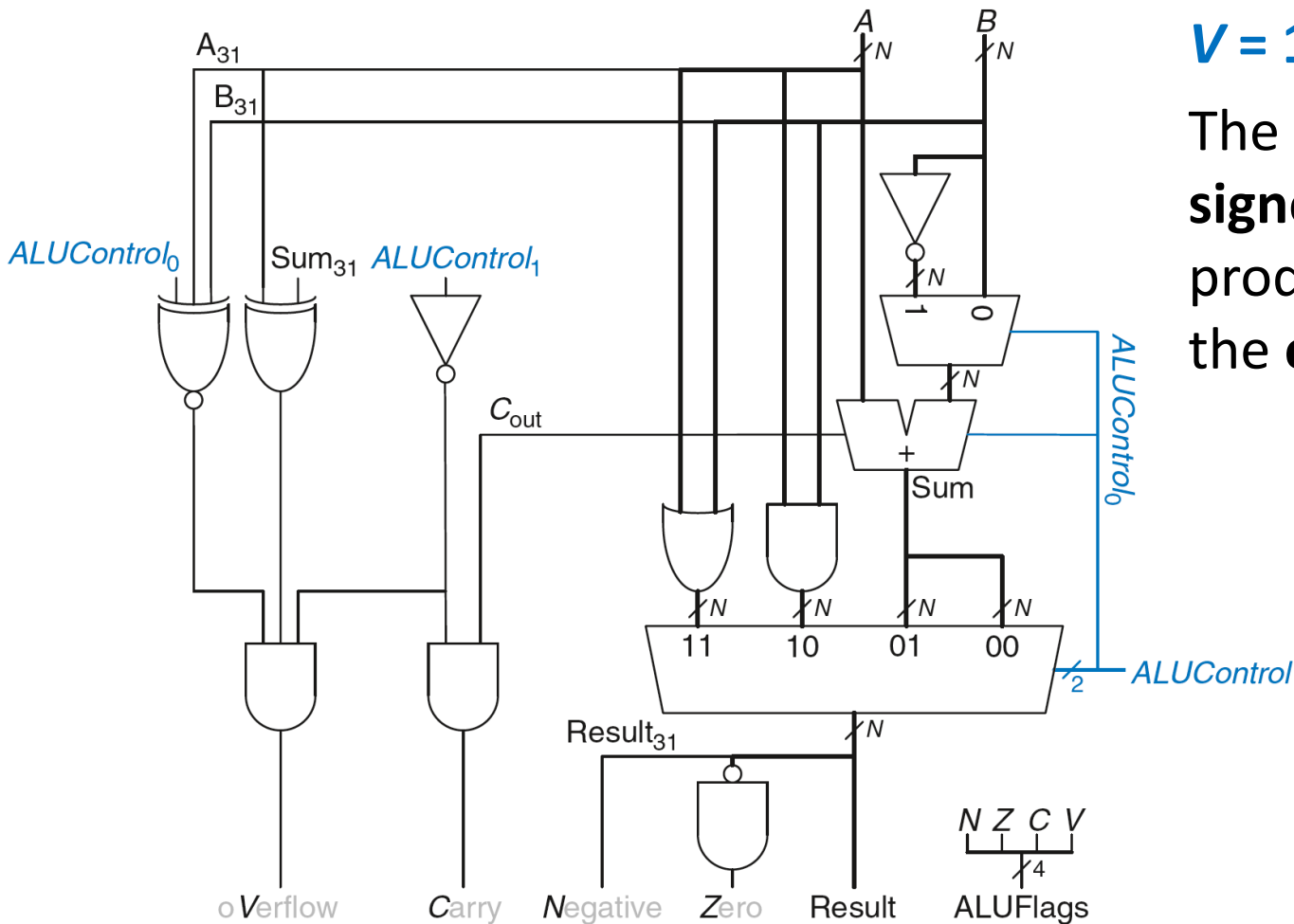

ALU with Status Flags: overflow

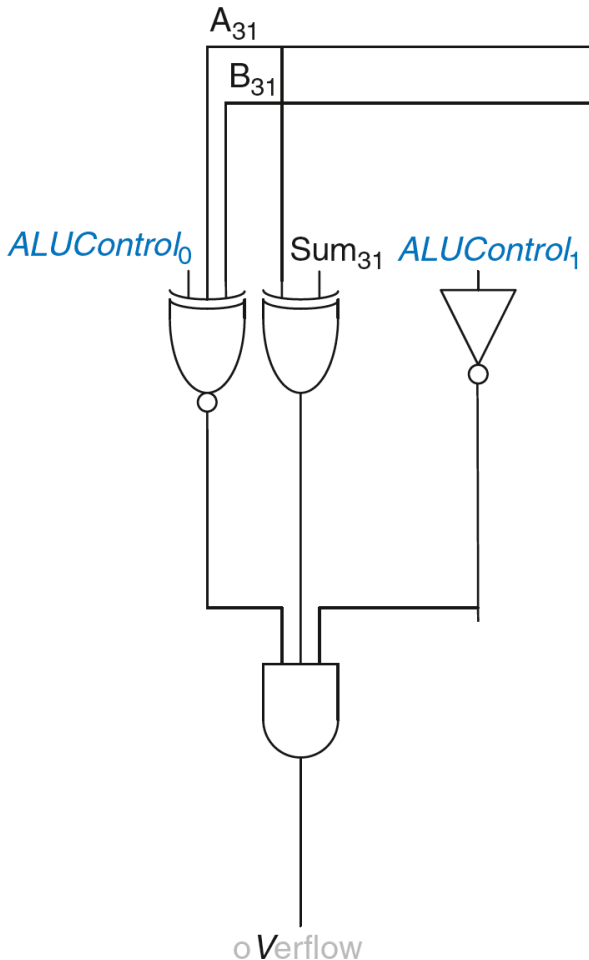

$V = 1$ if:

ALU is performing addition or subtraction
($ALUControl_1 = 0$)

AND

A and Sum have opposite signs

AND

A and B have same signs for addition
($ALUControl_0 = 0$)

OR

A and B have different signs for subtraction
($ALUControl_0 = 1$)

Comparison based on Flags

Compare by subtracting and checking flags

Different for signed and unsigned

Comparison	Signed	Unsigned
==	Z	Z
!=	$\sim Z$	$\sim Z$
<	$N \wedge V$	$\sim C$
<=	$Z \mid (N \wedge V)$	$Z \mid \sim C$
>	$\sim Z \ \& \ \sim(N \wedge V)$	$\sim Z \ \& \ C$
>=	$\sim(N \wedge V)$	C

Other ALU Operations

- **Set Less Than** (also called Set if Less Than)
 - **Sets lsb** of result **if $A < B$**
 - Result = 0000...001 if $A < B$
 - Result = 0000...000 otherwise
 - Comes in signed and unsigned flavors
- **XOR**
 - Result = $A \text{ XOR } B$

Extending ALU: SLT

ALUControl _{2:0}	Function
00	add
01	subtract
10	and
11	or
	SLT

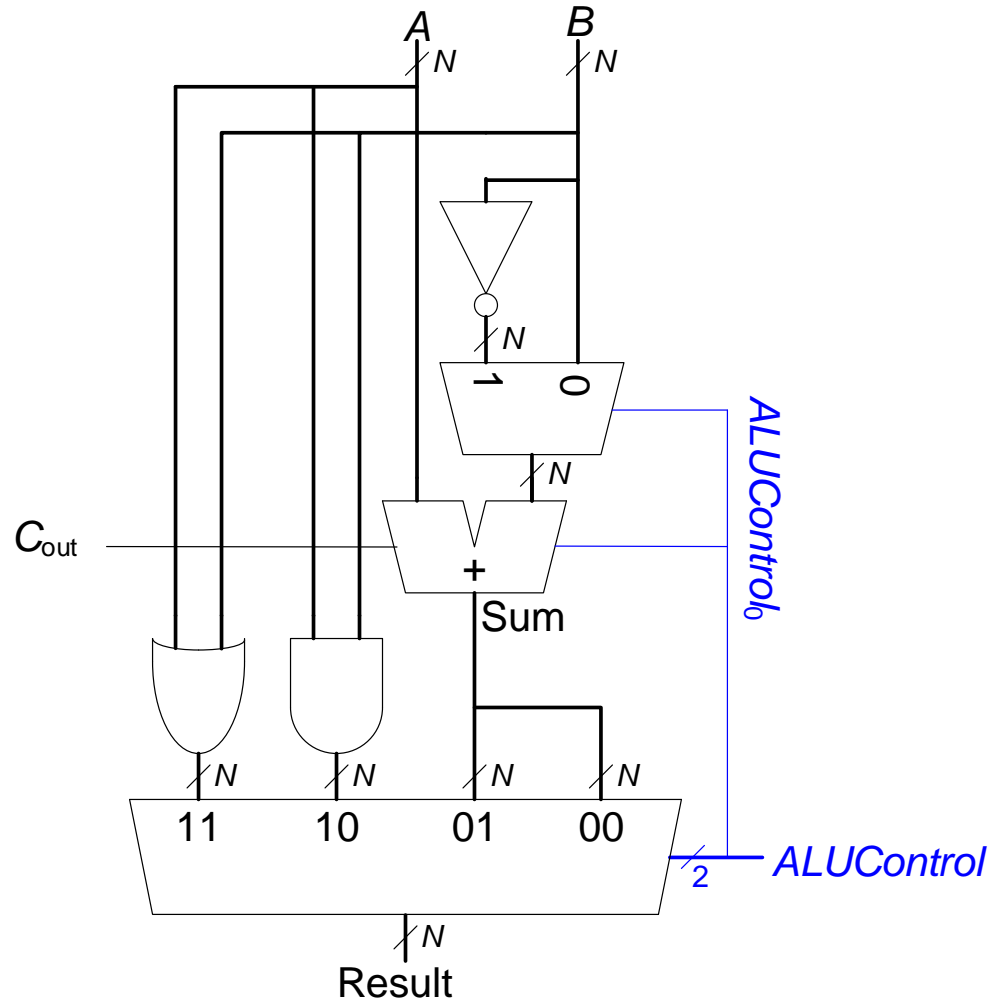

Fixing Overflow Error in SLT Logic

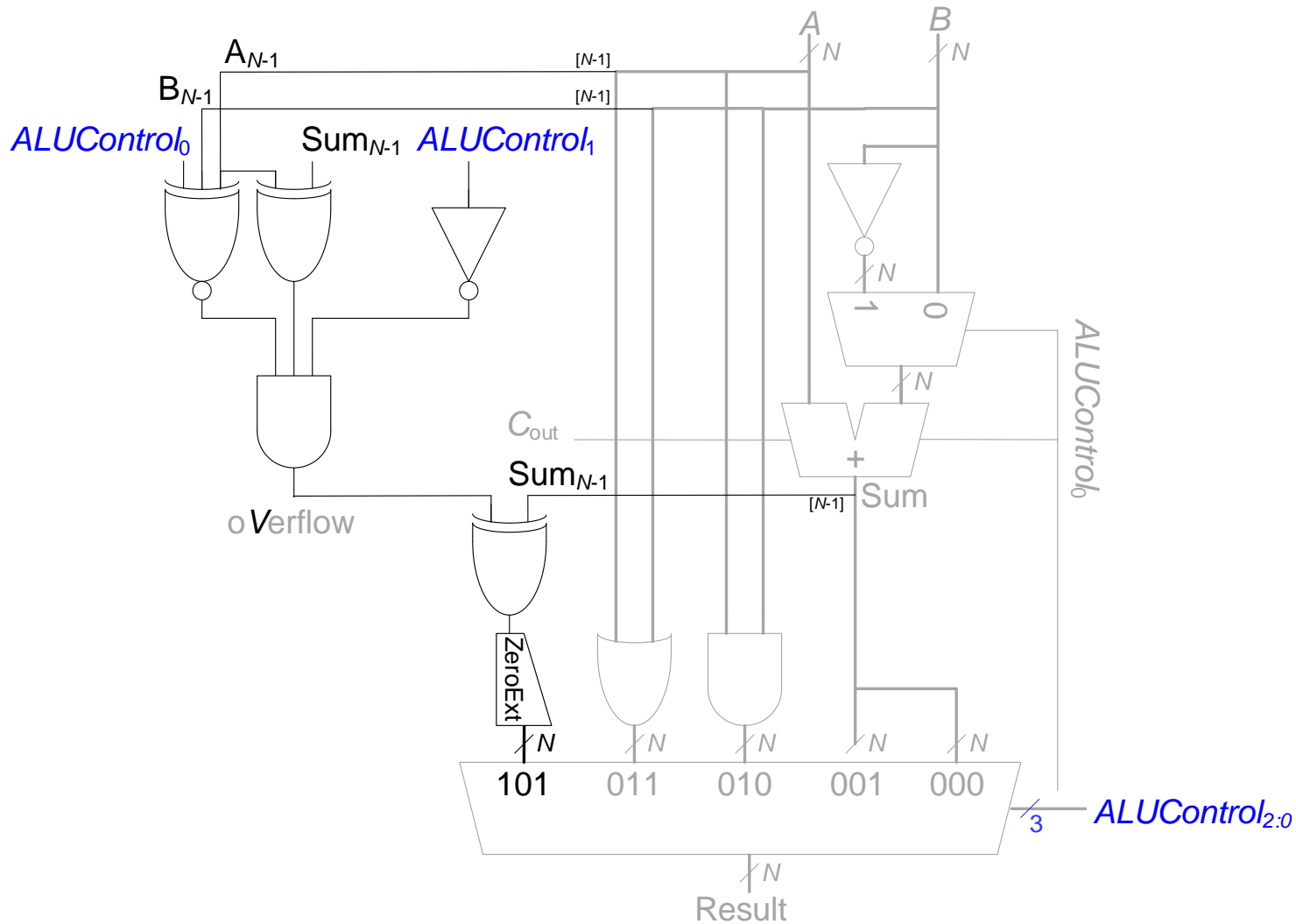

Chapter 5: Digital Building Blocks

Shifters, Multipliers, & Dividers

Shifters

Logical shifter: shifts value to left or right and fills empty spaces with 0's

- Ex: 11001 >> 2 =
- Ex: 11001 << 2 =

Arithmetic shifter: same as logical shifter, but on right shift, fills empty spaces with the old most significant bit (msb)

- Ex: 11001 >>> 2 =
- Ex: 11001 <<< 2 =

Rotator: rotates bits in a circle, such that bits shifted off one end are shifted into the other end

- Ex: 11001 ROR 2 =
- Ex: 11001 ROL 2 =

Shifter Design

Shift Left

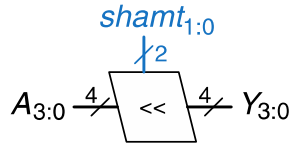

Logical Shift Right

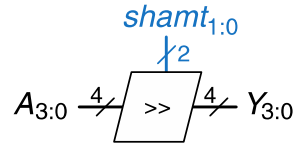

Arithmetic Shift Right

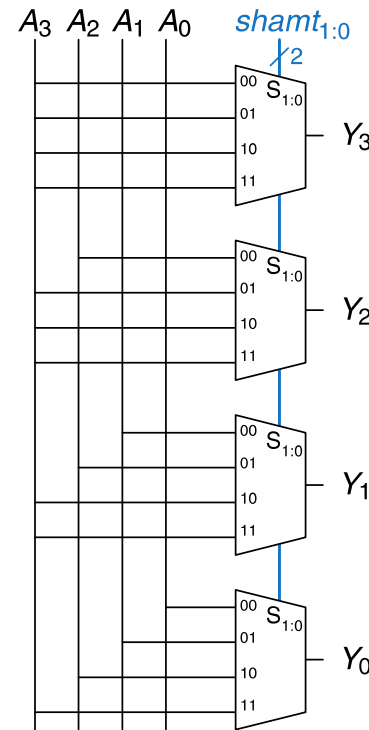
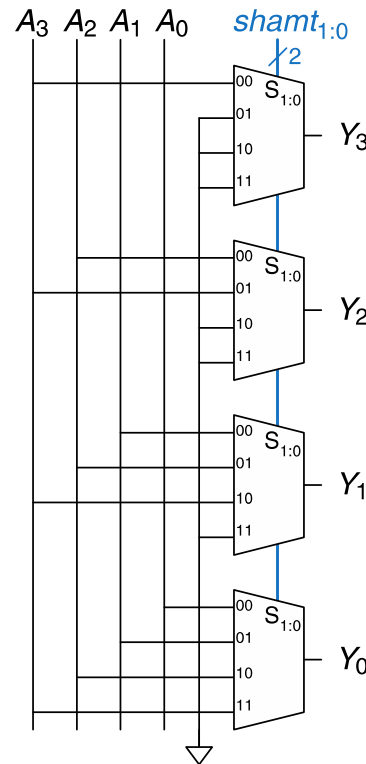
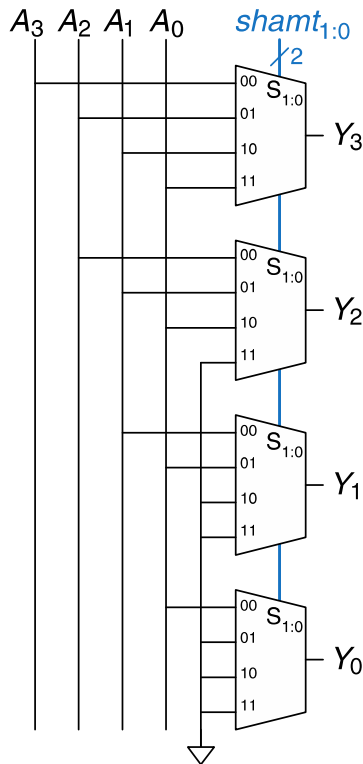
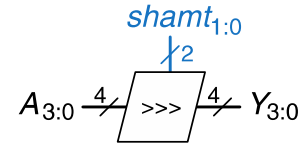

Shifters as Multipliers and Dividers

- $A \ll N = A \times 2^N$
- $A \gg N = A \div 2^N$

Multipliers

- **Partial products** formed by multiplying a single digit of the multiplier with multiplicand
- **Shifted** partial products **summed** to form result

Decimal

$$\begin{array}{r} 230 \\ \times 42 \\ \hline 460 \\ + 920 \\ \hline 9660 \end{array}$$

$$230 \times 42 = 9660$$

Binary

multiplicand	0101
multiplier	x 0111
partial products	<hr/> 0101 0101 0101 + 0000
result	<hr/> 0100011

$$5 \times 7 = 35$$

4 x 4 Multiplier

$$\begin{array}{r}
 \\
 \\
 \\
 \\
 + \\
 \hline
 P_7
 \end{array}$$

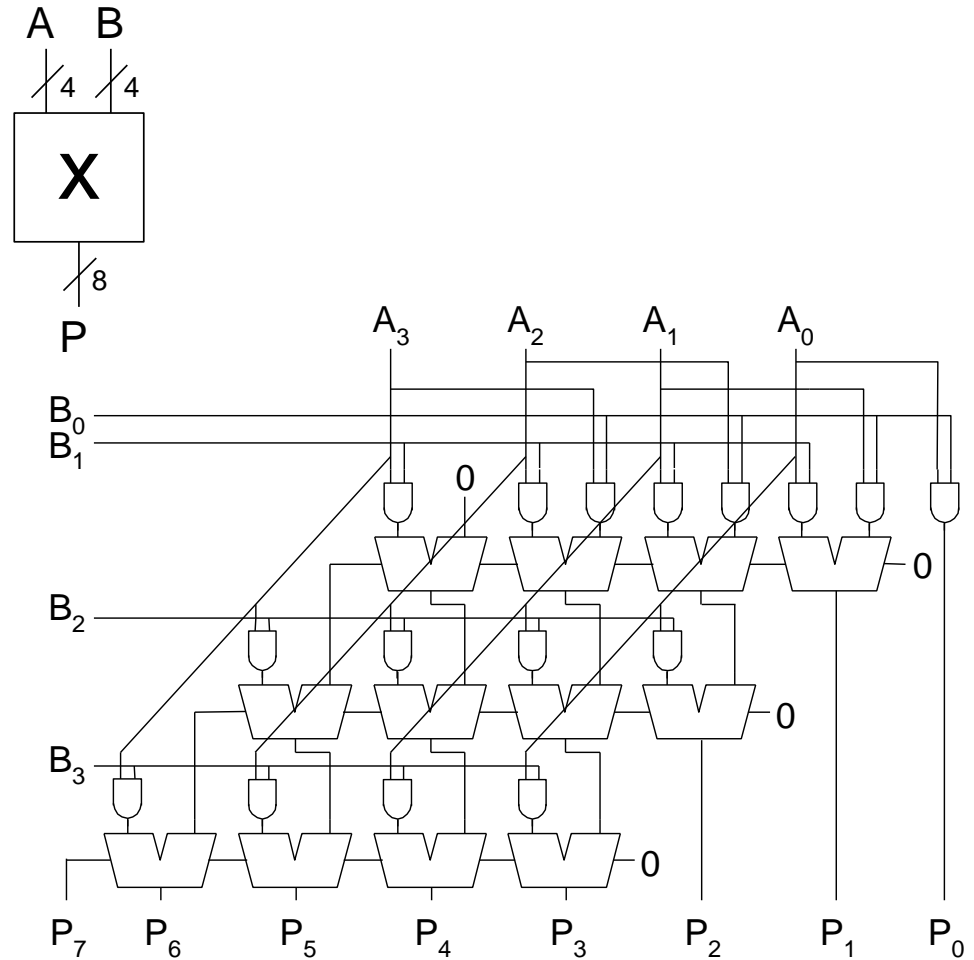

Dividers

$$A/B = Q + R/B$$

Decimal Example: $2584/15 = 172 \text{ R}4$

Long-Hand:

$$\begin{array}{r} 172 \text{ R}4 \\ 15 \overline{) 2584} \\ \underline{-15} \\ 108 \\ \underline{-105} \\ 34 \\ \underline{-30} \\ 4 \end{array}$$

Long-Hand Revisited:

$$\begin{array}{r} 0002 \\ - 15 \\ \hline -13 \end{array} \quad \begin{array}{r} 0 \\ \hline 3 \end{array}$$
$$\begin{array}{r} 0025 \\ - 15 \\ \hline 10 \end{array} \quad \begin{array}{r} 0 1 \\ \hline 3 \end{array}$$
$$\begin{array}{r} 0108 \\ - 105 \\ \hline 3 \end{array} \quad \begin{array}{r} 0 1 7 \\ \hline 3 \end{array}$$
$$\begin{array}{r} 0034 \\ - 30 \\ \hline 4 \end{array} \quad \begin{array}{r} 0 1 7 2 \\ \hline 3 \end{array}$$

Dividers

$$A/B = Q + R/B$$

Decimal: 2584/15 = 172 R4 **Binary:** 1101/0010 = 0110 R1

$$\begin{array}{r} 0002 \\ - 15 \\ \hline -13 \end{array}$$

$$\begin{array}{cccc} 0 & & & \\ \hline 3 & 2 & 1 & 0 \end{array}$$

$$\begin{array}{r} 0001 \\ - 0010 \\ \hline 1111 \end{array}$$

$$\begin{array}{cccc} 0 & & & \\ \hline 3 & 2 & 1 & 0 \end{array}$$

$$\begin{array}{r} 0025 \\ - 15 \\ \hline 10 \end{array}$$

$$\begin{array}{cccc} 0 & 1 & & \\ \hline 3 & 2 & 1 & 0 \end{array}$$

$$\begin{array}{r} 0011 \\ - 0010 \\ \hline 0001 \end{array}$$

$$\begin{array}{cccc} 0 & 1 & & \\ \hline 3 & 2 & 1 & 0 \end{array}$$

$$\begin{array}{r} 0108 \\ - 105 \\ \hline 3 \end{array}$$

$$\begin{array}{cccc} 0 & 1 & 7 & \\ \hline 3 & 2 & 1 & 0 \end{array}$$

$$\begin{array}{r} 0010 \\ - 0010 \\ \hline 0000 \end{array}$$

$$\begin{array}{cccc} 0 & 1 & 1 & \\ \hline 3 & 2 & 1 & 0 \end{array}$$

$$\begin{array}{r} 0034 \\ - 30 \\ \hline 4 \end{array}$$

$$\begin{array}{cccc} 0 & 1 & 7 & 2 \\ \hline 3 & 2 & 1 & 0 \end{array}$$

$$\begin{array}{r} 0001 \\ - 0010 \\ \hline 1111 \end{array}$$

$$\begin{array}{cccc} 0 & 1 & 1 & 0 \\ \hline 3 & 2 & 1 & 0 \end{array} \text{ R1}$$

Dividers

$$A/B = Q + R/B$$

$$R' = 0$$

for $i = N-1$ to 0

$$R = \{R' \ll 1, A_i\}$$

$$D = R - B$$

if $D < 0$, $Q_i = 0$; $R' = R$

else $Q_i = 1$; $R' = D$

$$R = R'$$

Binary: 1101/10 = 0110 R1

$\begin{array}{r} 0001 \\ -0010 \\ \hline 1111 \end{array}$	$\begin{array}{r} 0 \\ \hline 3 \quad 2 \quad 1 \quad 0 \end{array}$
$\begin{array}{r} 0011 \\ -0010 \\ \hline 0001 \end{array}$	$\begin{array}{r} 0 \quad 1 \\ \hline 3 \quad 2 \quad 1 \quad 0 \end{array}$
$\begin{array}{r} 0010 \\ -0010 \\ \hline 0000 \end{array}$	$\begin{array}{r} 0 \quad 1 \quad 1 \\ \hline 3 \quad 2 \quad 1 \quad 0 \end{array}$
$\begin{array}{r} 0001 \\ -0010 \\ \hline 1111 \end{array}$	$\begin{array}{r} 0 \quad 1 \quad 1 \quad 0 \\ \hline 3 \quad 2 \quad 1 \quad 0 \end{array} \text{ R1}$

4 x 4 Divider

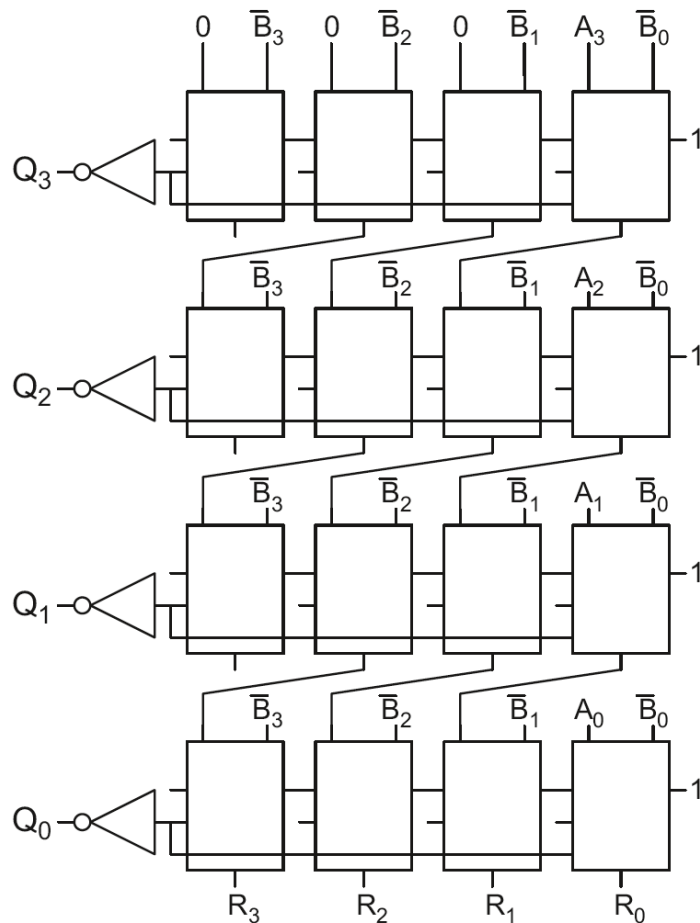

Legend

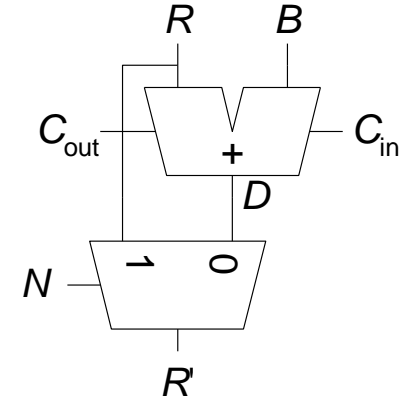
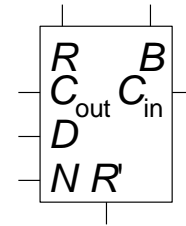

Division: $A/B = Q + R/B$

$R' = 0$

for $i = N-1$ to 0

$R = \{R' \ll 1, A_i\}$

$D = R - B$

if $D < 0$, $Q_i=0$, $R' = R$

else $Q_i=1$, $R' = D$

$R=R'$

Each row computes one iteration of the division algorithm.

4 x 4 Divider

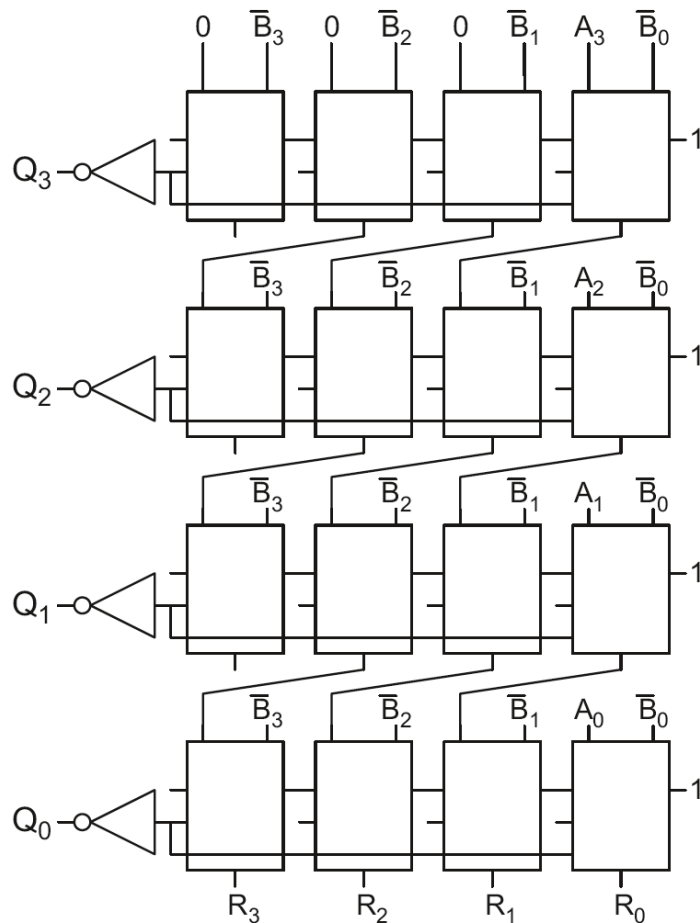

Legend

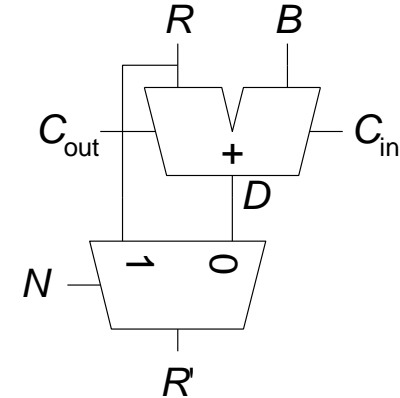
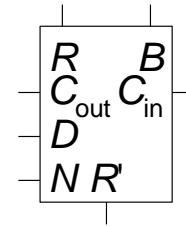

$$\begin{array}{r} 0001 \\ -0010 \\ \hline 1111 \end{array} \quad \begin{array}{r} 0 \\ \hline 3 \quad 2 \quad 1 \quad 0 \end{array}$$

$$\begin{array}{r} 0011 \\ -0010 \\ \hline 0001 \end{array} \quad \begin{array}{r} 0 \quad 1 \\ \hline 3 \quad 2 \quad 1 \quad 0 \end{array}$$

$$\begin{array}{r} 0010 \\ -0010 \\ \hline 0000 \end{array} \quad \begin{array}{r} 0 \quad 1 \quad 1 \\ \hline 3 \quad 2 \quad 1 \quad 0 \end{array}$$

$$\begin{array}{r} 0001 \\ -0010 \\ \hline 1111 \end{array} \quad \begin{array}{r} 0 \quad 1 \quad 1 \quad 0 \\ \hline 3 \quad 2 \quad 1 \quad 0 \end{array} \quad R1$$

Each row computes one iteration of the division algorithm.

Chapter 5: Digital Building Blocks

Fixed-Point Numbers

Number Systems

Numbers we can represent using binary representations

- **Positive numbers**
 - Unsigned binary
- **Negative numbers**
 - Two's complement
 - Sign/magnitude numbers

What about **fractions**?

Numbers with Fractions

Two common notations:

- **Fixed-point:** binary point fixed
- **Floating-point:** binary point floats to the right of the most significant 1

Fixed-Point Numbers

- 6.75 using 4 integer bits and 4 fraction bits:

01101100

0110.1100

$$2^2 + 2^1 + 2^{-1} + 2^{-2} = 6.75$$

- Binary point is implied
- The number of integer and fraction bits must be agreed upon beforehand

Unsigned Fixed Point Formats

- **Ua.b**: unsigned number with
 - **a** integer bits
 - **b** fractional bits.
- **Example: 6.75** is
 - **U4.4**: 01101100
 - **U3.5**: 11011000
 - **U6.2**: 00011011
- 8, 16, and 32-bit fixed point numbers are common
 - **U8.8** often represents sensor data, audio, pixels
 - **U16.16** used for higher precision signal processing

Signed Fixed Point Formats

- **Qa.b**: signed 2's complement number with
 - **a** integer bits (including the sign bit)
 - **b** fractional bits
- **To negate a Q fixed point number:**
 - Invert the bits
 - Add one to the LSB
- **Example:** write **-6.75** in Q4.4
 - 6.75 = 01101100
 - Invert: 10010011
 - Add 1 LSB: 10010100
- **Q1.15** (aka Q15) is common for signal processing (1, -1]

Saturating Arithmetic

- Fixed point **overflow** is usually bad
 - Produces undesired artifacts:
 - Video: dark pixel in middle of bright pixels
 - Audio: clicking sounds
- **Saturating arithmetic**
 - Instead of overflowing, use largest value
 - In U4.4: $11000000 + 01111000 = 11111111$
 $12 \quad + 7.5 \quad = 15.9375$

Chapter 5: Digital Building Blocks

Floating-Point Numbers

Floating-Point Numbers

- Binary point floats to the right of the most significant 1
- Similar to decimal scientific notation

- For example, write 273_{10} in scientific notation:

$$273 = 2.73 \times 10^2$$

- In general, a number is written in scientific notation as:

$$\pm \mathbf{M} \times \mathbf{B}^{\mathbf{E}}$$

- **M** = mantissa
- **B** = base
- **E** = exponent
- In the example, $M = 2.73$, $B = 10$, and $E = 2$

Floating vs. Fixed Point Numbers

- Floating point numbers are like **scientific notation**
 - Allow a **greater dynamic range** of smallest to largest
 - **Arithmetic is harder**
 - Mantissa must be aligned before adding
 - This costs performance and power
- Fixed point numbers are **harder for the programmer**
 - **Smaller dynamic range**
 - Take care of **overflow**
- **Floating Point** is preferred for general-purpose computing where programming time is most important
- **Fixed Point** is preferred for signal processing performance, power, and hardware cost matter most
 - Machine learning, video

Floating-Point Numbers

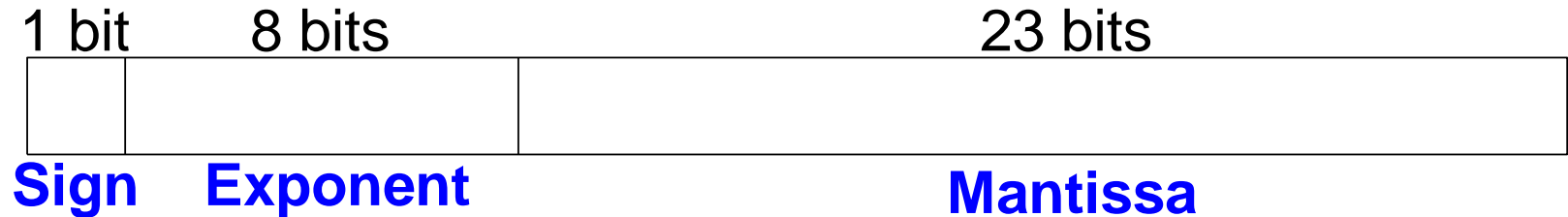

- **Example:** represent the value 228_{10} using a 32-bit floating point representation

We show three versions – **the final version** is called the:

IEEE 754 floating-point standard

Floating-Point Representation 1

1. Convert decimal to binary:

$$228_{10} = 11100100_2$$

2. Write the number in “binary scientific notation”:

$$11100100_2 = 1.11001_2 \times 2^7$$

3. Fill in each field of the 32-bit floating point number:

- The sign bit is positive (0)
- The 8 exponent bits represent the value 7
- The remaining 23 bits are the mantissa

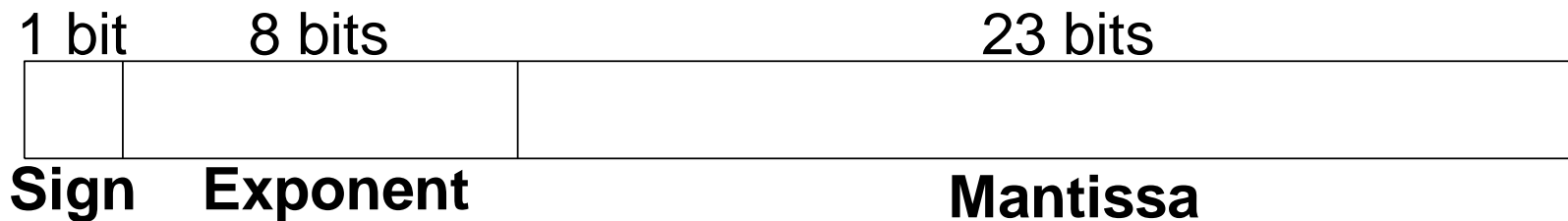

Floating-Point Representation 2

- First bit of the mantissa is always 1:
 - $228_{10} = 11100100_2 = \mathbf{1.11001} \times 2^7$
- So, no need to store it: *implicit leading 1*
- Store just **fraction bits** in 23-bit field

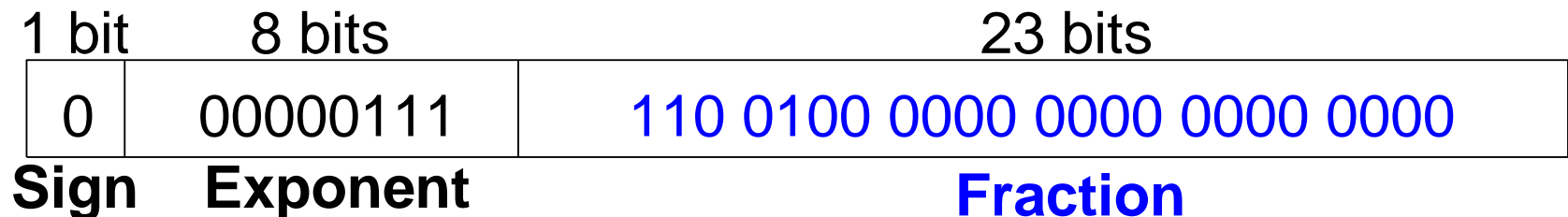

Floating-Point Representation 3

- **Biased exponent:** bias = 127 (01111111_2)

- Biased exponent = bias + exponent

- Exponent of 7 is stored as:

$$127 + 7 = 134 = 0x10000110_2$$

- The **IEEE 754 32-bit floating-point representation** of 228_{10}

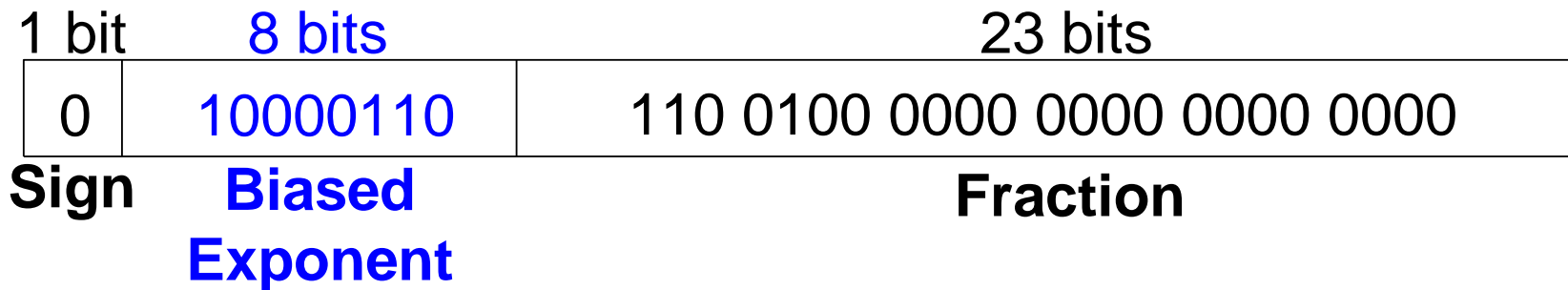

in hexadecimal: **0x43640000**

Floating-Point Example

Write -58.25_{10} in floating point (IEEE 754)

1. Convert magnitude of decimal to binary:

$$58.25_{10} = 111010.01_2$$

2. Write in binary scientific notation:

$$1.1101001 \times 2^5$$

3. Fill in fields:

Sign bit: 1 (negative)

8 exponent bits: $(127 + 5) = 132 = 10000100_2$

23 fraction bits: 110 1001 0000 0000 0000 0000

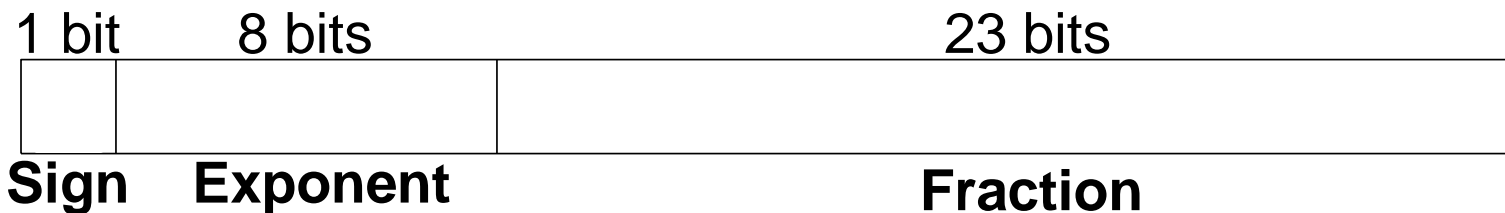

in hexadecimal: **0xC2690000**

Floating-Point Special Cases

Number	Sign	Exponent	Fraction
0	X	00000000	0000000000000000000000000000
∞	0	11111111	0000000000000000000000000000
$-\infty$	1	11111111	0000000000000000000000000000
NaN	X	11111111	non-zero

Floating-Point Precision

- **Single-Precision:**
 - 32-bit
 - 1 sign bit, 8 exponent bits, 23 fraction bits
 - bias = 127
- **Double-Precision:**
 - 64-bit
 - 1 sign bit, 11 exponent bits, 52 fraction bits
 - bias = 1023

Floating-Point Rounding & Overflow

- **Overflow:** number too large to be represented
- **Underflow:** number too small to be represented
- **Rounding modes:**
 - Down
 - Up
 - Toward zero
 - To nearest
- **Example:** round 1.100101 (1.578125) to only 3 fraction bits
 - **Down:** 1.100
 - **Up:** 1.101
 - **Toward zero:** 1.100
 - **To nearest:** 1.101 (1.625 is closer to 1.578125 than 1.5 is)

Chapter 5: Digital Building Blocks

Floating-Point Addition

Floating-Point Addition

1. **Extract** exponent and fraction bits
2. **Prepend** leading 1 to form mantissa
3. **Compare** exponents
4. **Shift** smaller mantissa if necessary
5. **Add** mantissas
6. **Normalize** mantissa and adjust exponent if necessary
7. **Round** result
8. **Assemble** exponent and fraction back into floating-point format

Floating-Point Addition Example

Add the following floating-point numbers:

0x3FC00000

0x40500000

Floating-Point Addition Example

1. Extract exponent and fraction bits

0x3FC00000	1 bit 0	8 bits 01111111	23 bits 100 0000 0000 0000 0000 0000
	Sign	Exponent	Fraction
0x40500000	1 bit 0	8 bits 10000000	23 bits 101 0000 0000 0000 0000 0000
	Sign	Exponent	Fraction

For first number (N1): $S = 0, E = 127, F = .1$

For second number (N2): $S = 0, E = 128, F = .101$

2. Prepend leading 1 to form mantissa

N1: 1.1

N2: 1.101

Floating-Point Addition Example

3. Compare exponents

$127 - 128 = -1$, so shift N1 right by 1 bit

4. Shift smaller mantissa if necessary

shift N1's mantissa: $1.1 \gg 1 = 0.11$ ($\times 2^1$)

5. Add mantissas

$$\begin{array}{r} 0.11 \times 2^1 \\ + 1.101 \times 2^1 \\ \hline 10.011 \times 2^1 \end{array}$$

Floating-Point Addition Example

6. Normalize mantissa and adjust exponent if necessary

$$10.011 \times 2^1 = 1.0011 \times 2^2$$

7. Round result

No need (fits in 23 bits)

8. Assemble exponent and fraction back into floating-point format

$$S = 0, E = 2 + 127 = 129 = 10000001_2, F = 001100\dots$$

1 bit	8 bits	23 bits
0	10000001	001 1000 0000 0000 0000 0000
Sign	Exponent	Fraction

in hexadecimal: **0x40980000**

Chapter 5: Digital Building Blocks

Counters & Shift Registers

Counters

- Increments on each clock edge
- Used to cycle through numbers. For example,
 - 000, 001, 010, 011, 100, 101, 110, 111, 000, 001...
- **Example uses:**
 - Digital clock displays
 - Program counter: keeps track of current instruction executing

Symbol

Implementation

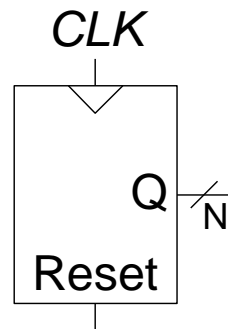

Counter SystemVerilog Idiom

```
module counter(input logic clk, reset,
               output logic [7:0] q);

    always_ff @(posedge clk)
        if (reset) q <= 0; // synchronous reset
        else      q <= q+1; //
end
```

```
// alternative more verbose
module counter(input logic clk, reset,
               output logic [7:0] q);

    logic [7:0] nextq;

    assign nextq = q + 1; // adder
    always_ff @(posedge clk) // state register with synchronous reset
        if (reset) q <= 0;
        else      q <= nextq;
end
```

Divide-by- 2^N Counter

- Most significant bit of an N-bit counter toggles every 2^N cycles.
- Useful for slowing a clock. Ex: blink an LED
- Example: 50 MHz clock, 24-bit counter
 - 2.98 Hz

Digitally Controlled Oscillator

- N-bit counter
- Add p on each cycle, instead of 1
- Most significant bit toggles at $f_{\text{out}} = f_{\text{clk}} * p / 2^N$

- Example: $f_{\text{clk}} = 50$ MHz clock
 - How to generate a $f_{\text{out}} = 200$ Hz signal?
 - $p/2^N = 200 / 50$ MHz
- Try $N = 24$, $p = 67 \rightarrow f_{\text{out}} = 199.676$ Hz
- Or $N = 32$, $p = 17179 \rightarrow f_{\text{out}} = 199.990$ Hz

Shift Registers

- Shift a new bit in on each clock edge
- Shift a bit out on each clock edge
- *Serial-to-parallel converter*: converts serial input (S_{in}) to parallel output ($Q_{0:N-1}$)

Symbol:

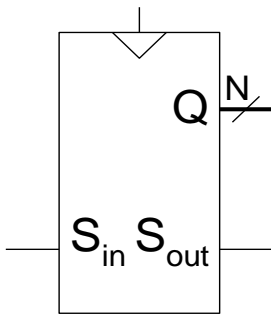

Implementation:

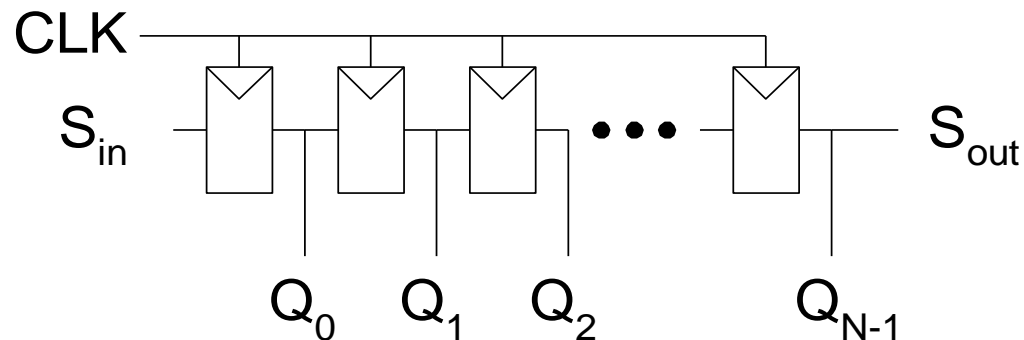

Shift Register with Parallel Load

- When $Load = 1$, acts as a normal N -bit register
- When $Load = 0$, acts as a shift register
- Now can act as a *serial-to-parallel converter* (S_{in} to $Q_{0:N-1}$) or a *parallel-to-serial converter* ($D_{0:N-1}$ to S_{out})

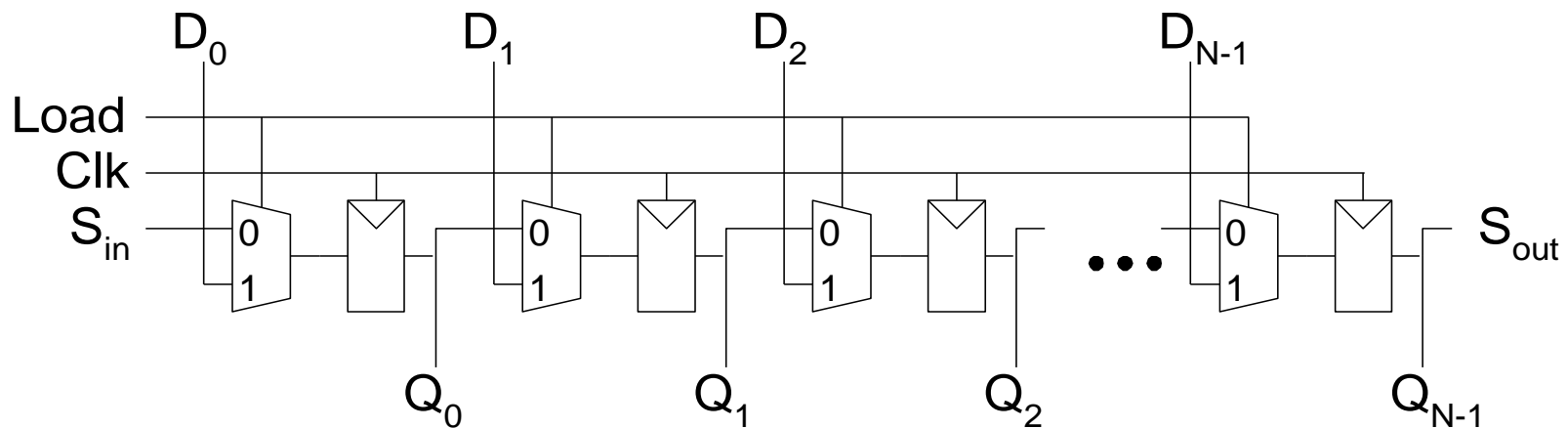

Shift Register SystemVerilog Idiom

```
module shiftreg #(parameter N=8)
    (input  logic          clk,
     input  logic          reset, load,
     input  logic          sin,
     input  logic [N-1:0] d,
     output logic [N-1:0] q,
     output logic          sout);

    always_ff @(posedge clk, posedge reset)
        if (reset)      q <= 0;
        else if (load)  q <= d;
        else             q <= {q[N-2:0], sin};

    assign sout = q[N-1];
end
```

Chapter 5: Digital Building Blocks

Memory

Memory Arrays

- Efficiently store large amounts of data
- M -bit data value read/written at each unique N -bit address
- 3 common types:
 - Dynamic random access memory (DRAM)
 - Static random access memory (SRAM)
 - Read only memory (ROM)

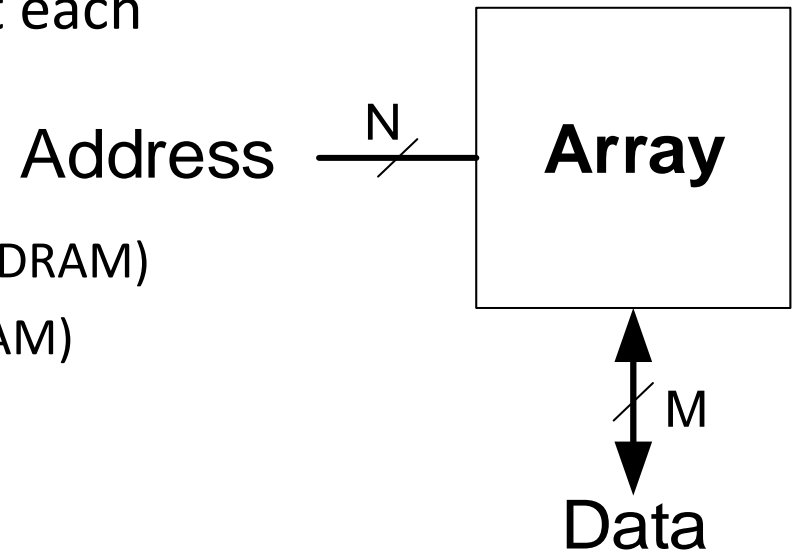

Memory Arrays

- 2-dimensional array of bit cells
- Each bit cell stores one bit
- N address bits and M data bits:
 - 2^N rows and M columns
 - **Depth:** number of rows (number of words)
 - **Width:** number of columns (size of word)
 - **Array size:** depth \times width = $2^N \times M$

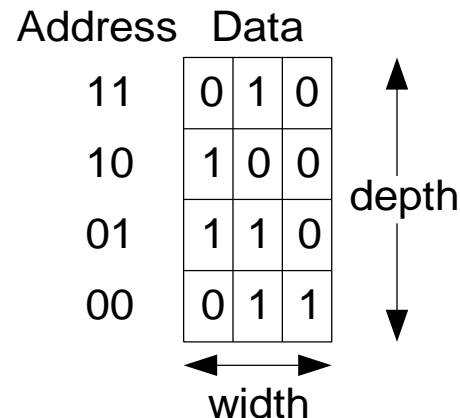
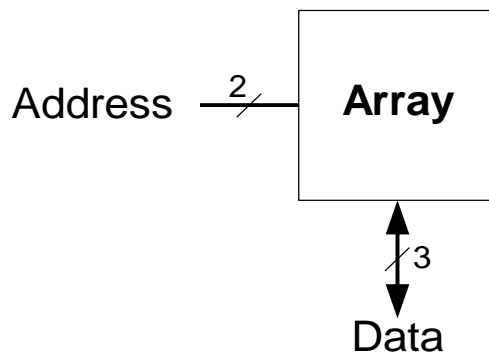
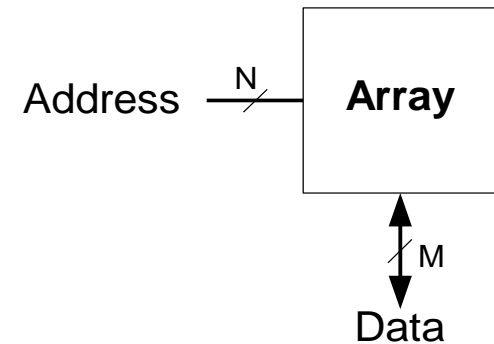

Memory Array Example

- $2^2 \times 3$ -bit array
- Number of words: 4
- Word size: 3-bits
- For example, the 3-bit word stored at address 10 is 100

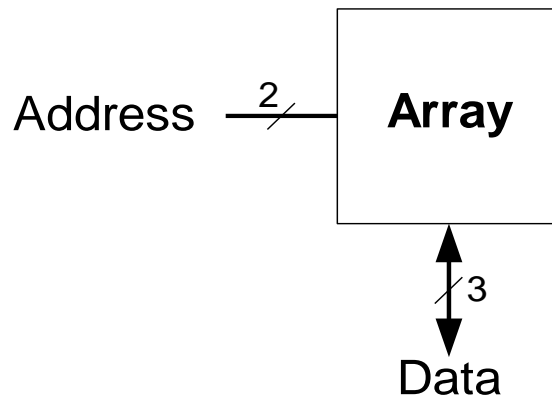

Address	Data		
11	0	1	0
10	1	0	0
01	1	1	0
00	0	1	1

A vertical double-headed arrow to the right of the table is labeled "depth". A horizontal double-headed arrow below the table is labeled "width".

Memory Arrays

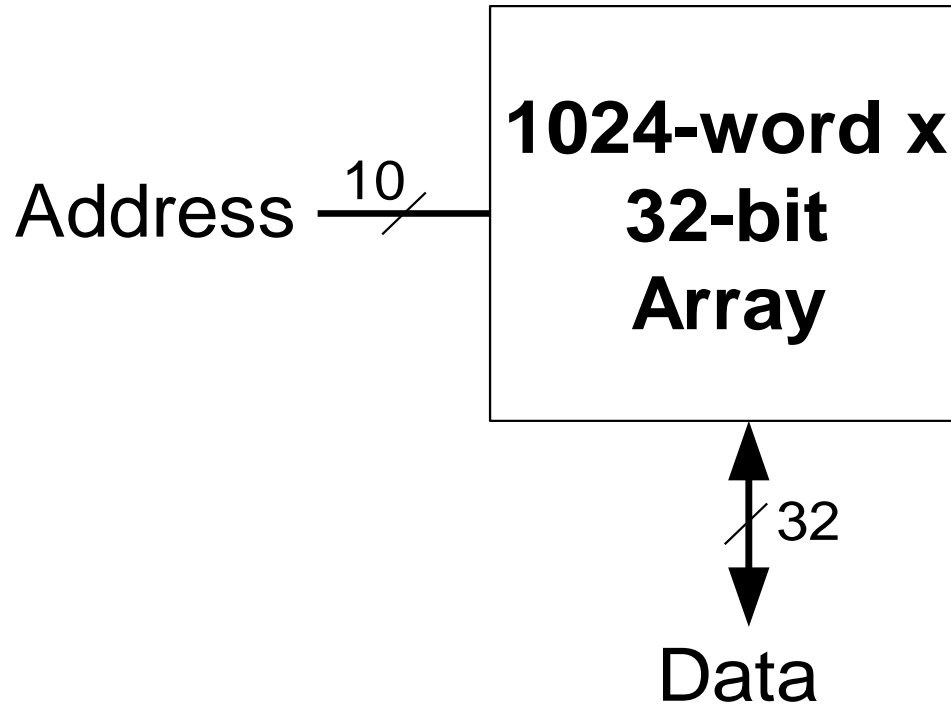

Memory Array Bit Cells

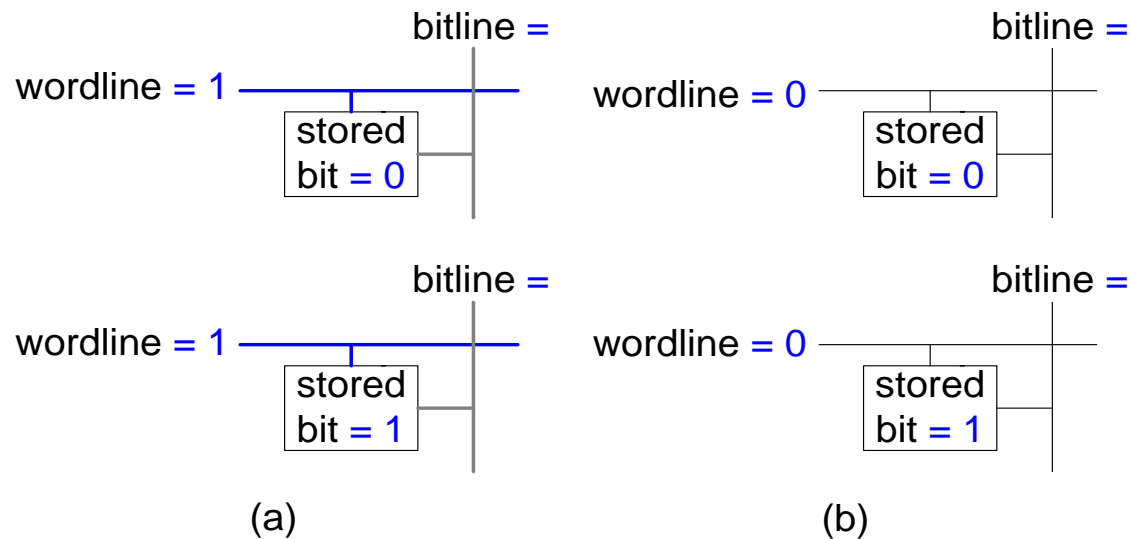
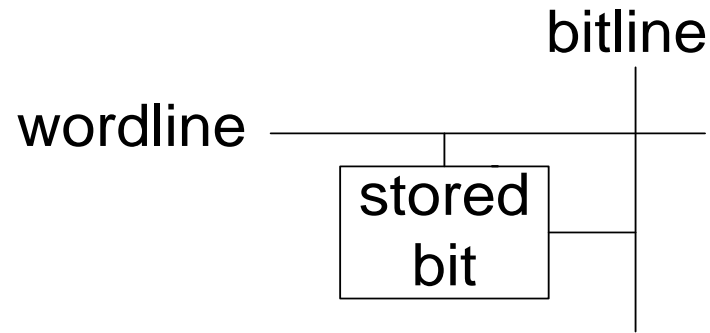

Memory Array

- **Wordline:**
 - like an enable
 - single row in memory array read/written
 - corresponds to unique address
 - only one wordline **HIGH** at once

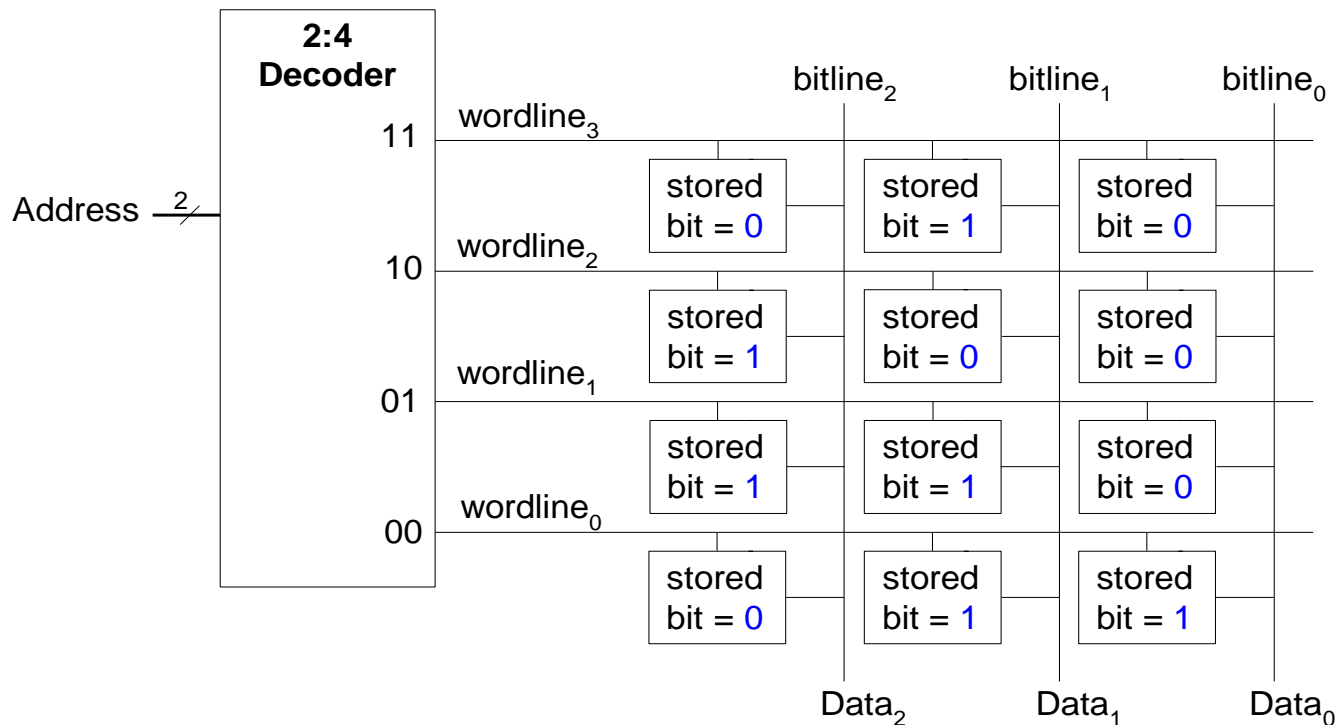

Types of Memory

- Random access memory (RAM): **volatile**
- Read only memory (ROM): **nonvolatile**

RAM: Random Access Memory

- **Volatile:** loses its data when power off
- Read and written quickly
- Main memory in your computer is RAM (DRAM)

Historically called *random access* memory because any data word accessed as easily as any other (in contrast to sequential access memories such as a tape recorder)

ROM: Read Only Memory

- **Nonvolatile:** retains data when power off
- Read quickly, but writing is impossible or slow
- Flash memory in cameras, thumb drives, and digital cameras are all ROMs

Historically called *read only* memory because ROMs were written at time of fabrication or by burning fuses. Once a ROM was configured, it could not be written again. This is no longer the case for Flash memory and other types of ROMs.

Chapter 5: Digital Building Blocks

RAM

Types of RAM

- **DRAM** (Dynamic random access memory)
- **SRAM** (Static random access memory)
- Differ in how they store data:
 - DRAM uses a capacitor
 - SRAM uses cross-coupled inverters

Robert Dennard, 1932 -

- Invented DRAM in 1966 at IBM
- Others were skeptical that the idea would work
- By the mid-1970's DRAM in virtually all computers



DRAM

- Data bits stored on **capacitor**
- *Dynamic* because the value needs to be **refreshed** (rewritten) periodically and after read:
 - Charge leakage from the capacitor degrades the value
 - Reading destroys the stored value

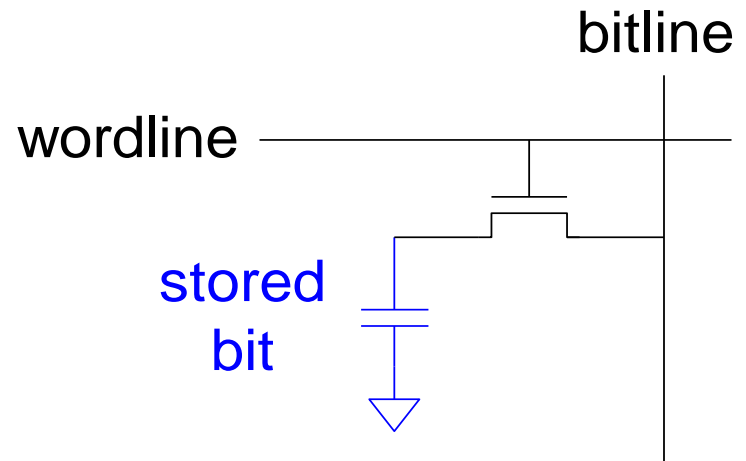
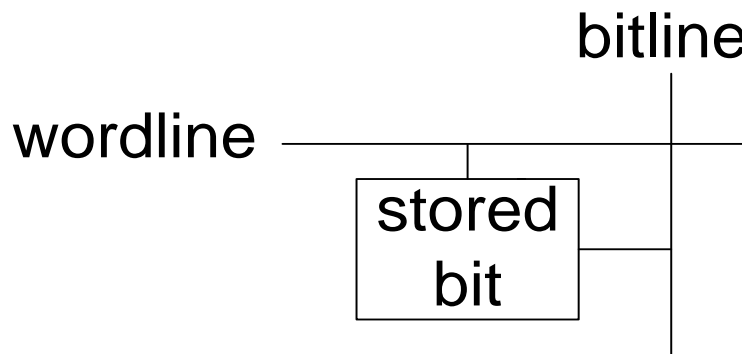

DRAM

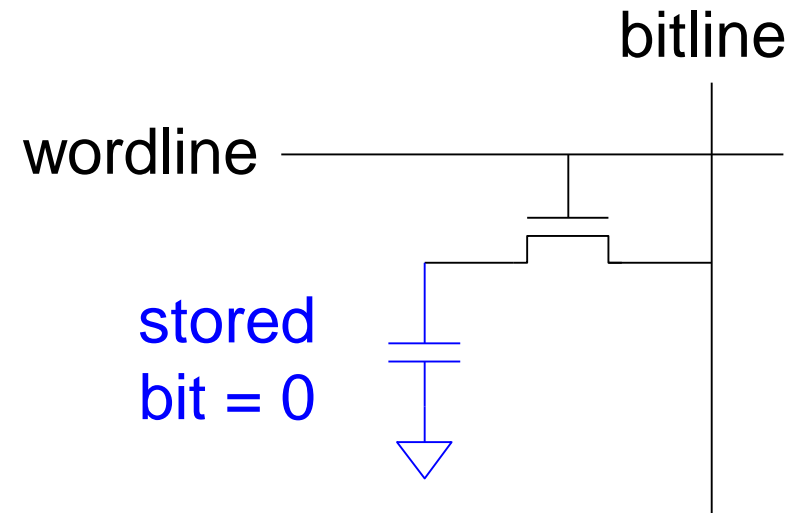
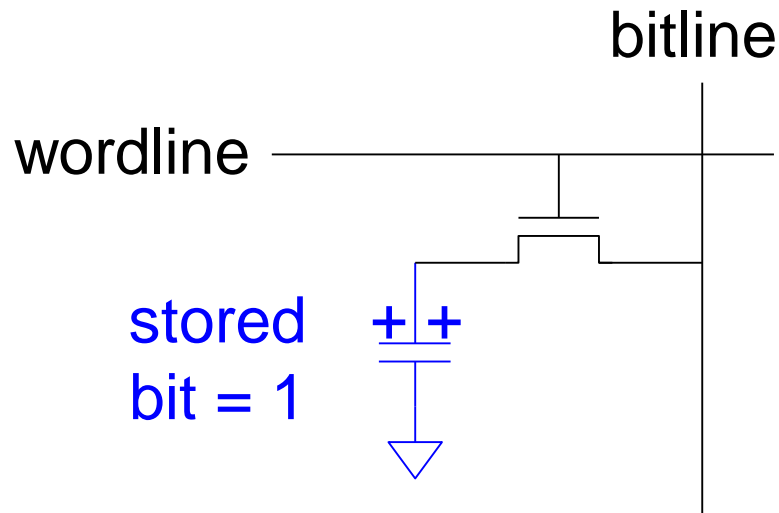

SRAM

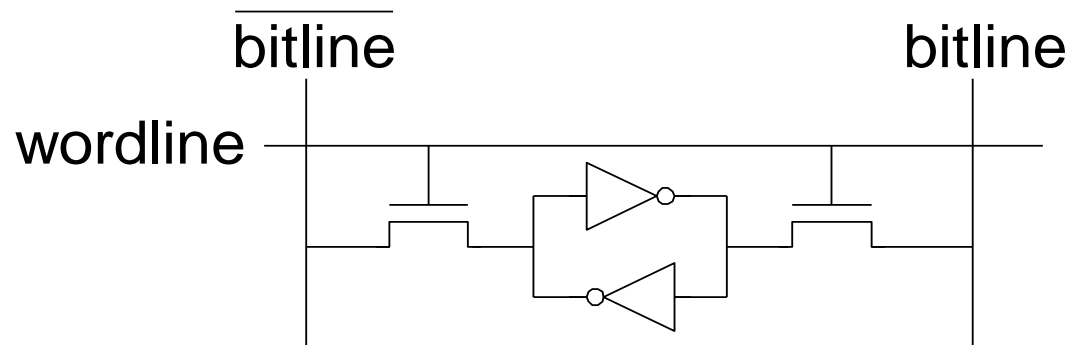
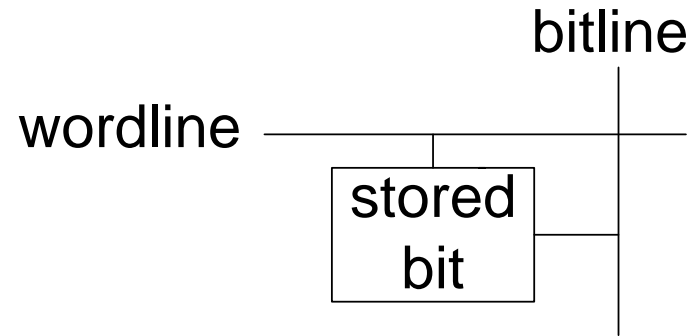

Chapter 5: Digital Building Blocks

ROM

ROM: Dot Notation

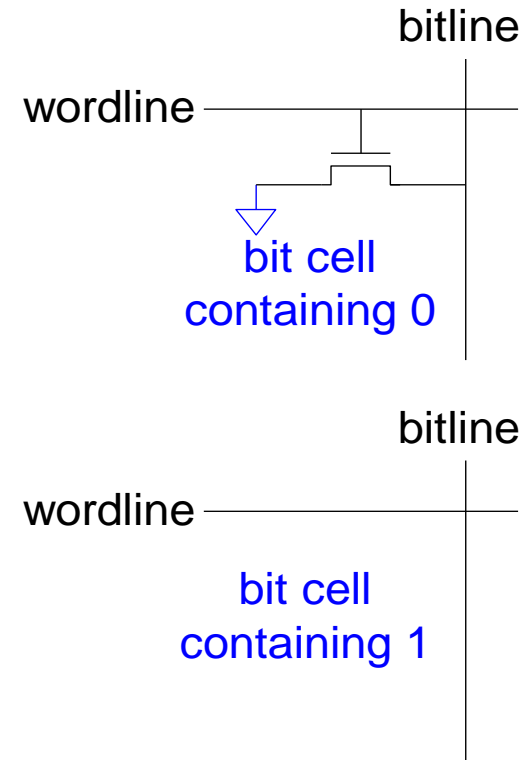
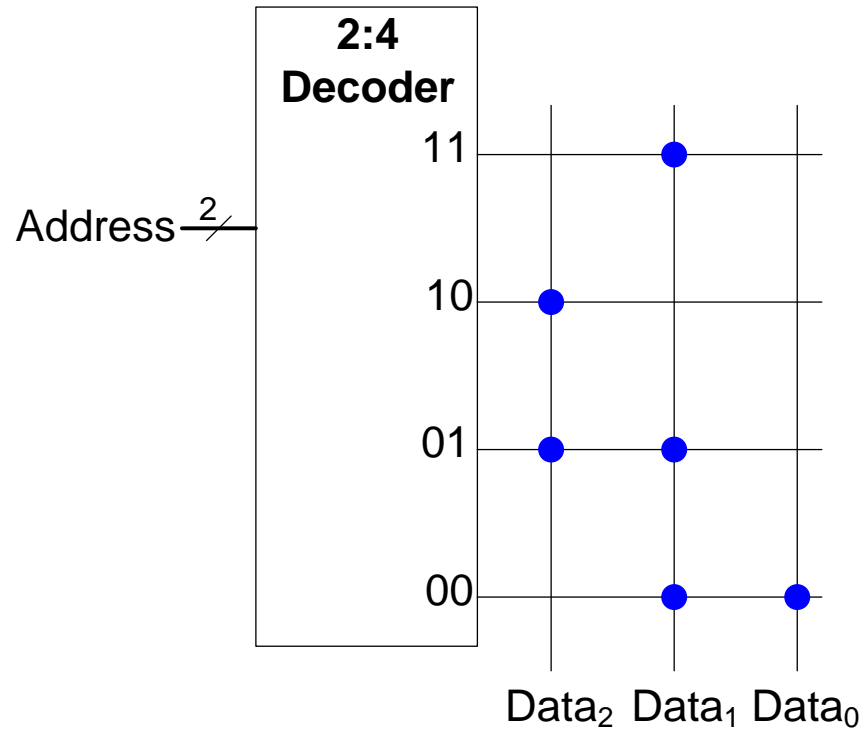

ROM Storage

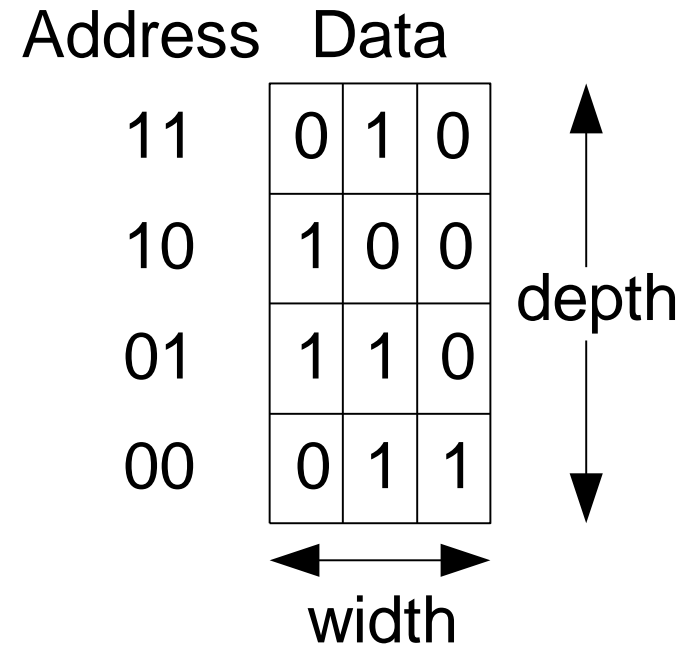
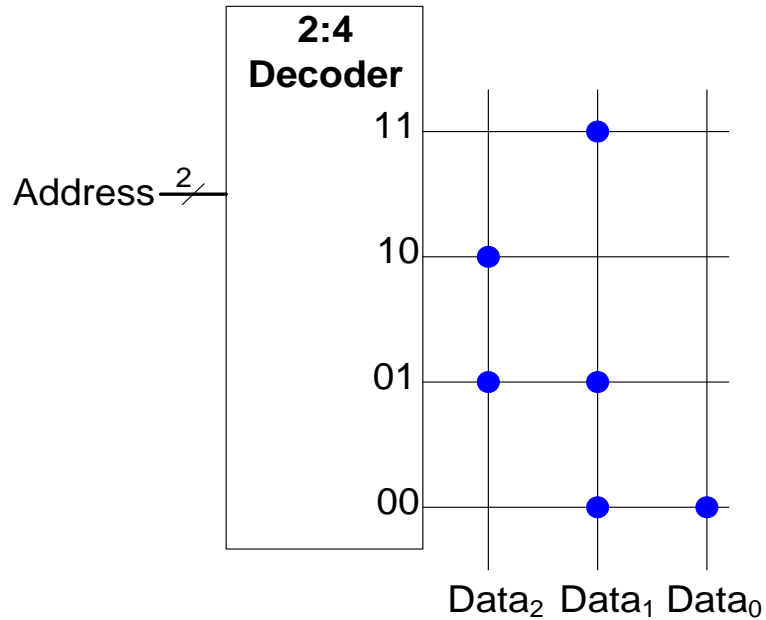

Fujio Masuoka, 1944 -

- Developed memories and high speed circuits at Toshiba, 1971-1994
- Invented Flash memory as an unauthorized project pursued during nights and weekends in the late 1970's
- The process of erasing the memory reminded him of the flash of a camera
- Toshiba slow to commercialize the idea; Intel was first to market in 1988
- Flash has grown into a \$25 billion per year market



ROM Logic

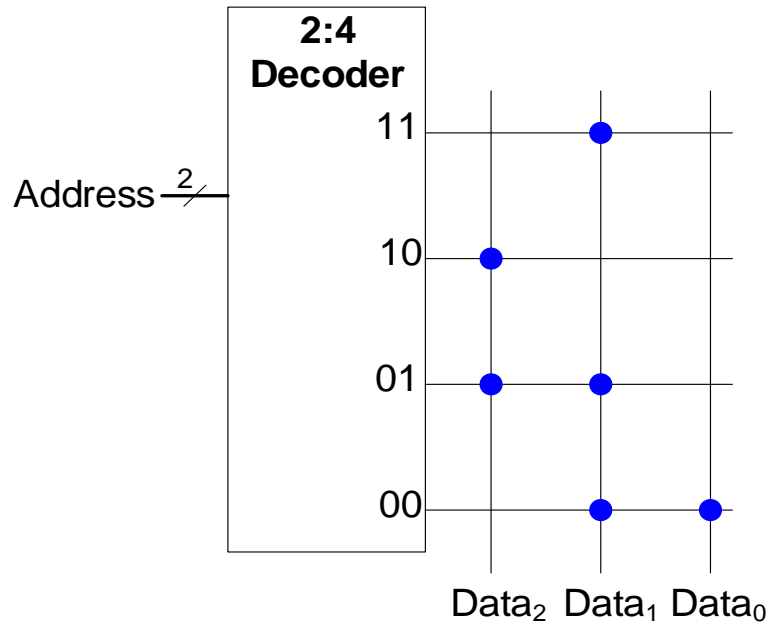

$$Data_2 = A_1 \oplus A_0$$

$$Data_1 = \bar{A}_1 + A_0$$

$$Data_0 = \bar{A}_1 \bar{A}_0$$

Example: Logic with ROMs

Implement the following logic functions using a $2^2 \times 3$ -bit ROM:

- $X = AB$
- $Y = A + B$
- $Z = A \overline{B}$

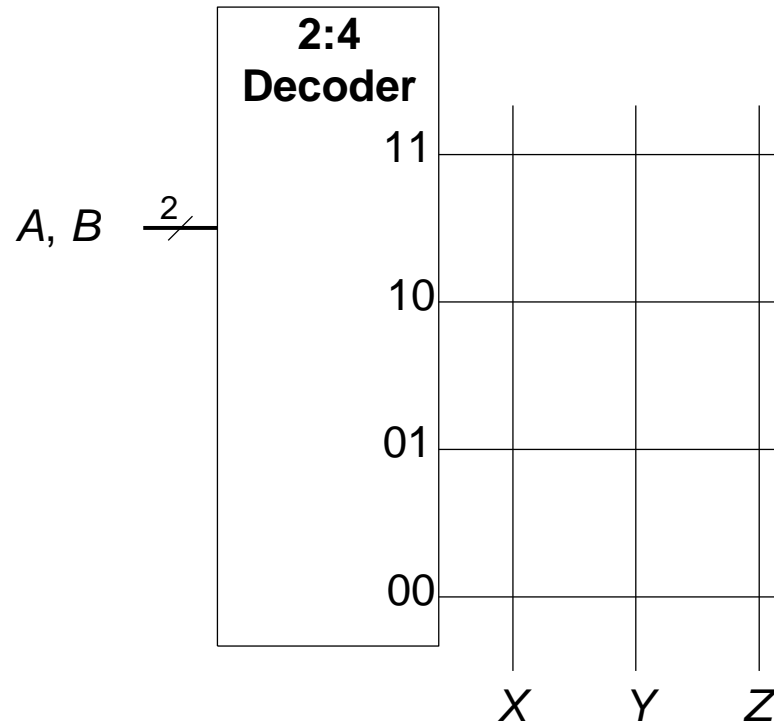

Logic with Any Memory Array

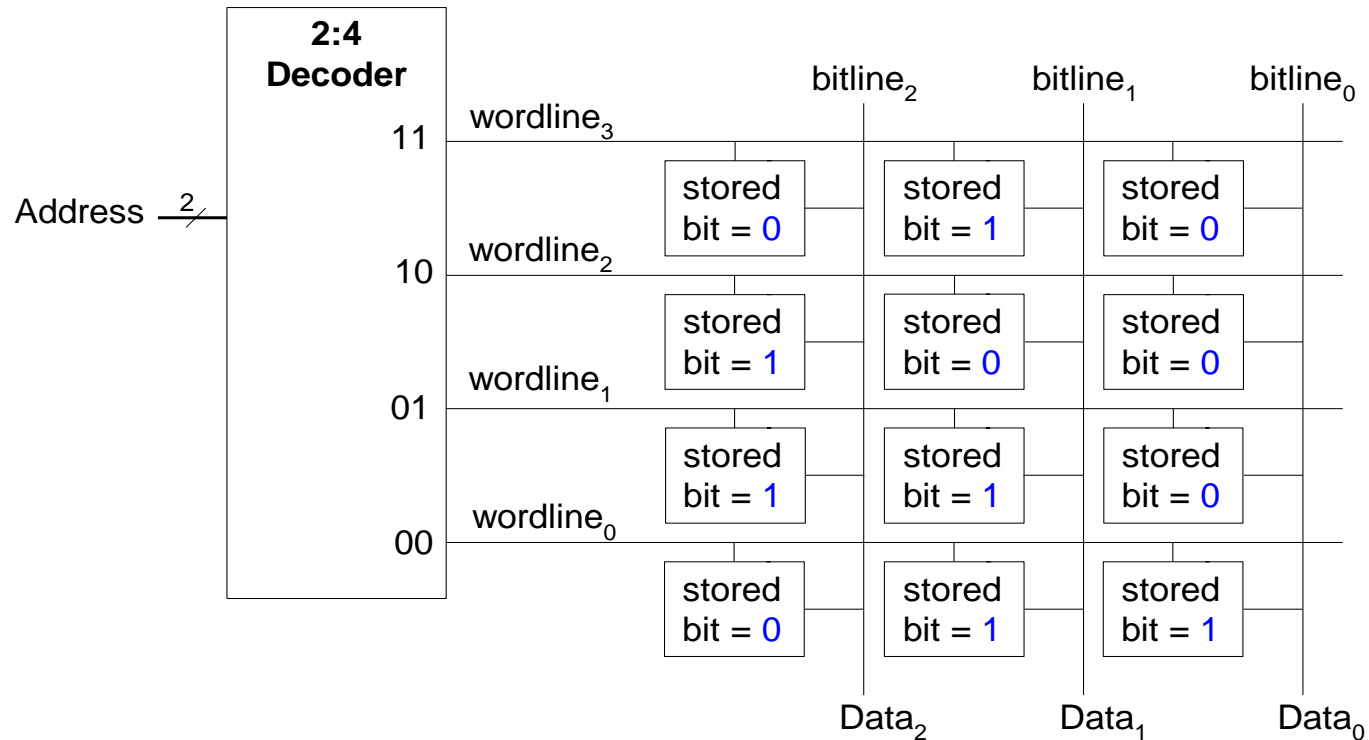

$Data_2 =$ _____

$Data_1 =$ _____

$Data_0 =$ _____

Logic with Memory Arrays

Implement the following logic functions using a $2^2 \times 3$ -bit memory array:

- $X = AB$
- $Y = A + B$
- $Z = A \overline{B}$

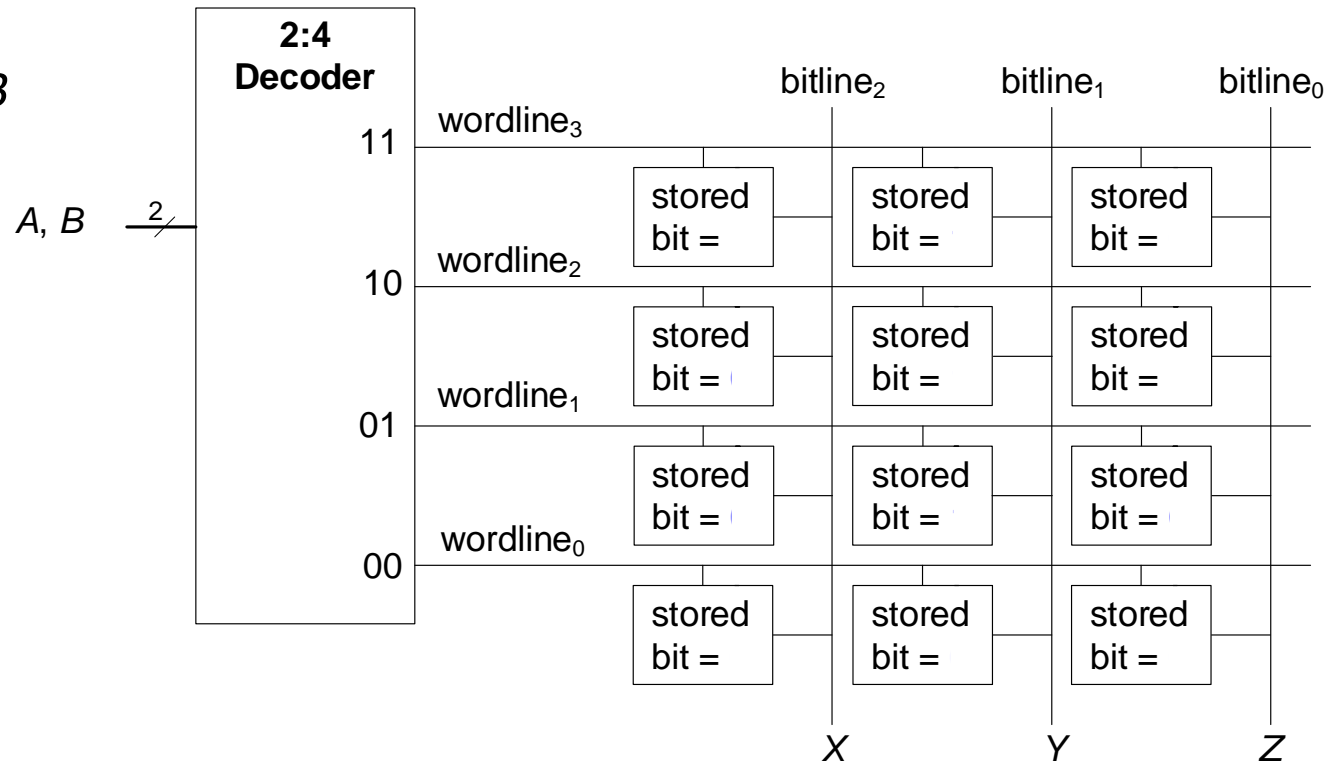

Logic with Memory Arrays

Called *lookup tables (LUTs)*: look up output at each input combination (address)

Truth Table

A	B	Y
0	0	0
0	1	0
1	0	0
1	1	1

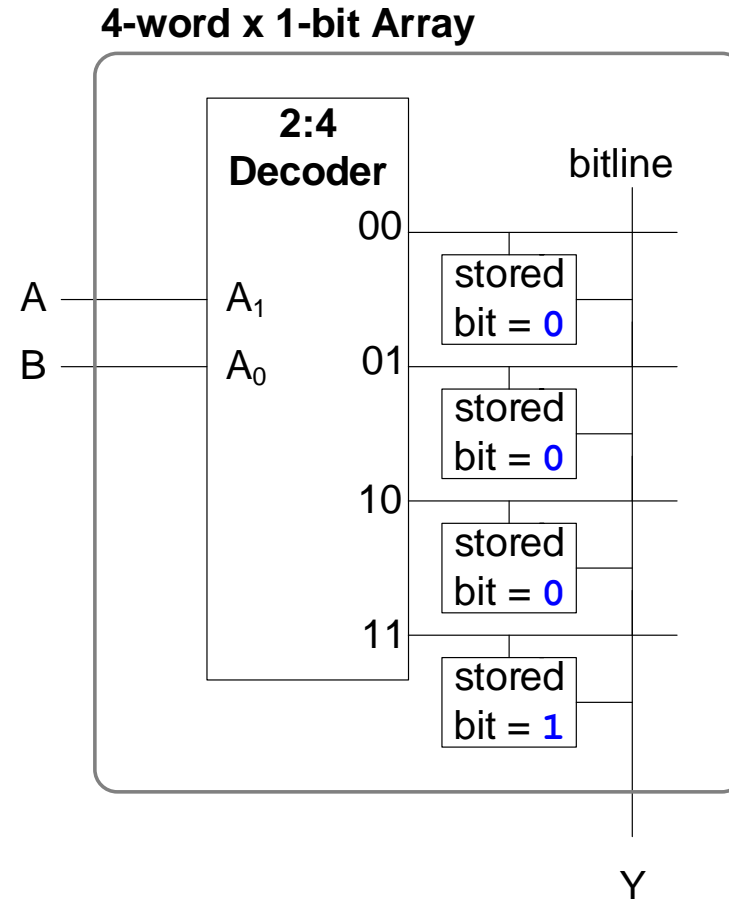

Chapter 5: Digital Building Blocks

SystemVerilog & Multiported Memories

SystemVerilog RAM

```
// 256 x 3 RAM with one read/write port
module ram(input logic clk, we,
           input logic [7:0] a,
           input logic [2:0] wd,
           output logic [2:0] rd);

    logic [2:0] RAM[255:0];

    assign rd = RAM[a];

    always @(posedge clk)
        if (we)
            RAM[a] <= wd;
endmodule
```

SystemVerilog ROM

```
// 128 x 32 ROM with one read port
// Contents initialized from file
module rom(input logic [6:0] a,
           output logic [31:0] rd);

    logic [31:0] ROM[127:0];

    // initialize contents from file
    initial
        $readmemh("memfile.dat", ROM);

    // read port
    assign rd = ROM[a];
endmodule
```

SystemVerilog ROM memfile

```
// memfile.dat
// Contains up to 128 lines of 32-bit hex numbers
// defining the contents of the ROM
01234567
89ABCDEF
FFFFFFFF
A5A5A5A5
...
```

Multi-ported Memories

- **Port:** address/data pair
- 3-ported memory
 - 2 read ports (A1/RD1, A2/RD2)
 - 1 write port (A3/WD3, WE3 enables writing)
- **Register file:** small multi-ported memory

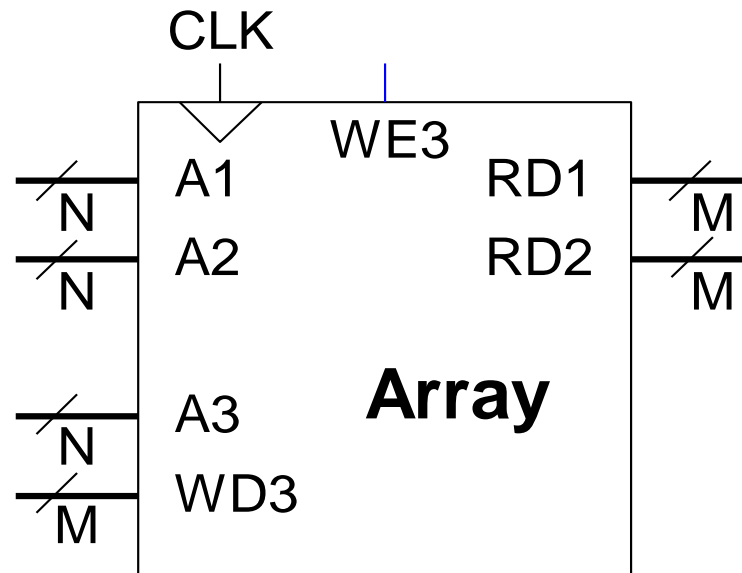

SystemVerilog Memory Arrays

```
// 32 x 32 register file with 2 read, 1 write port
// register 0 hardwired to read as 0
module regfile(input logic clk,
               input logic we3,
               input logic [4:0] ra1, ra2, wa3,
               input logic [31:0] wd3,
               output logic [31:0] rd1, rd2);

    logic [31:0] rf[31:0];

    always_ff @(posedge clk)
        if (we3) rf[wa3] <= wd3;

    assign rd1 = (ra1 == 5'b00000) ? 32'b0 : rf[ra1];
    assign rd2 = (ra2 == 5'b00000) ? 32'b0 : rf[ra2];
endmodule
```

Chapter 5: Digital Building Blocks

Logic Arrays: PLAs & FPGAs

Logic Arrays

- **PLAs** (Programmable logic arrays)
 - AND array followed by OR array
 - Combinational logic only
 - Fixed internal connections
- **FPGAs** (Field programmable gate arrays)
 - Array of Logic Elements (LEs)
 - Combinational and sequential logic
 - Programmable internal connections

PLAs: Programmable Logic Arrays

- $X = \bar{A}\bar{B}C + A\bar{B}C$
- $Y = A\bar{B}$

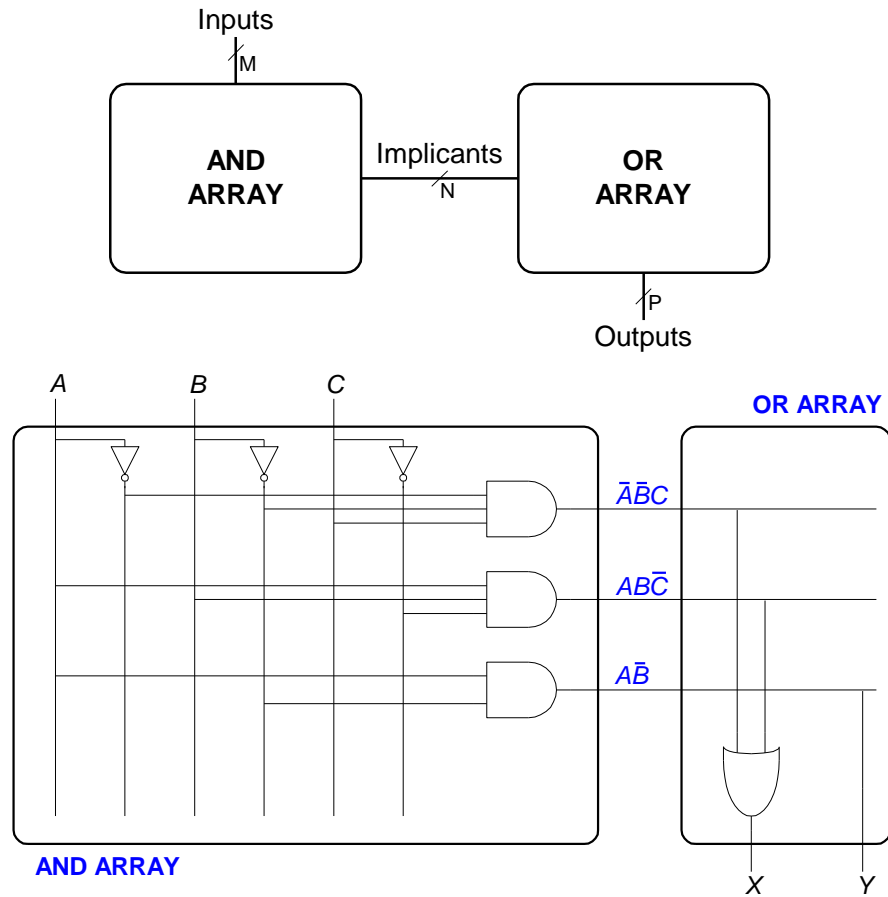

PLAs: Dot Notation

- $X = ABC + \bar{A}BC$
- $Y = AB$

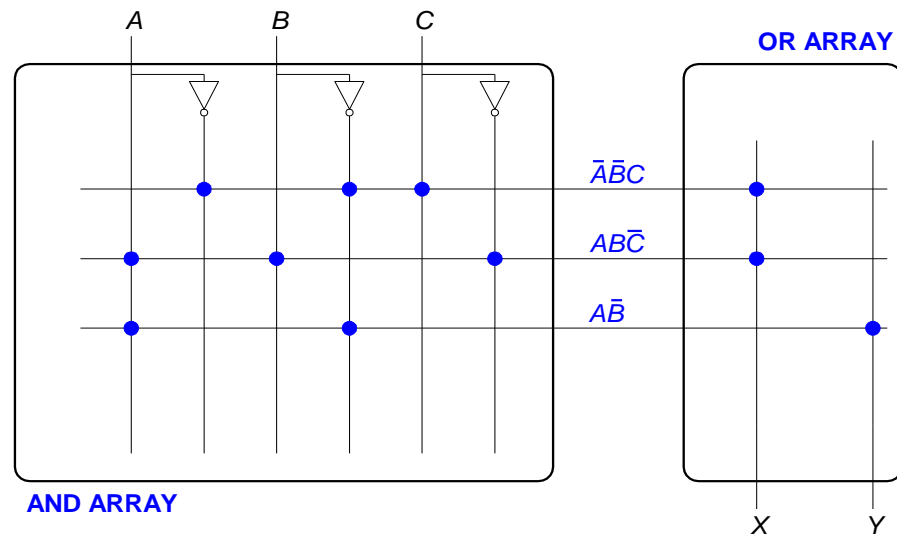
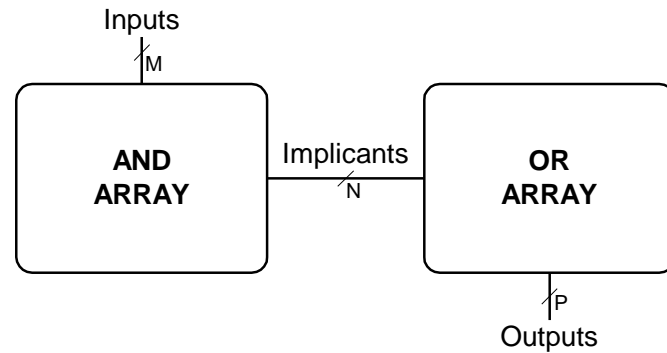

FPGAs: Field Programmable Gate Arrays

- Composed of:
 - **LEs** (Logic elements): perform logic
 - **IOEs** (Input/output elements): interface with outside world
 - **Programmable interconnection:** connect LEs and IOEs
 - Some FPGAs include other building blocks such as multipliers and RAMs

General FPGA Layout

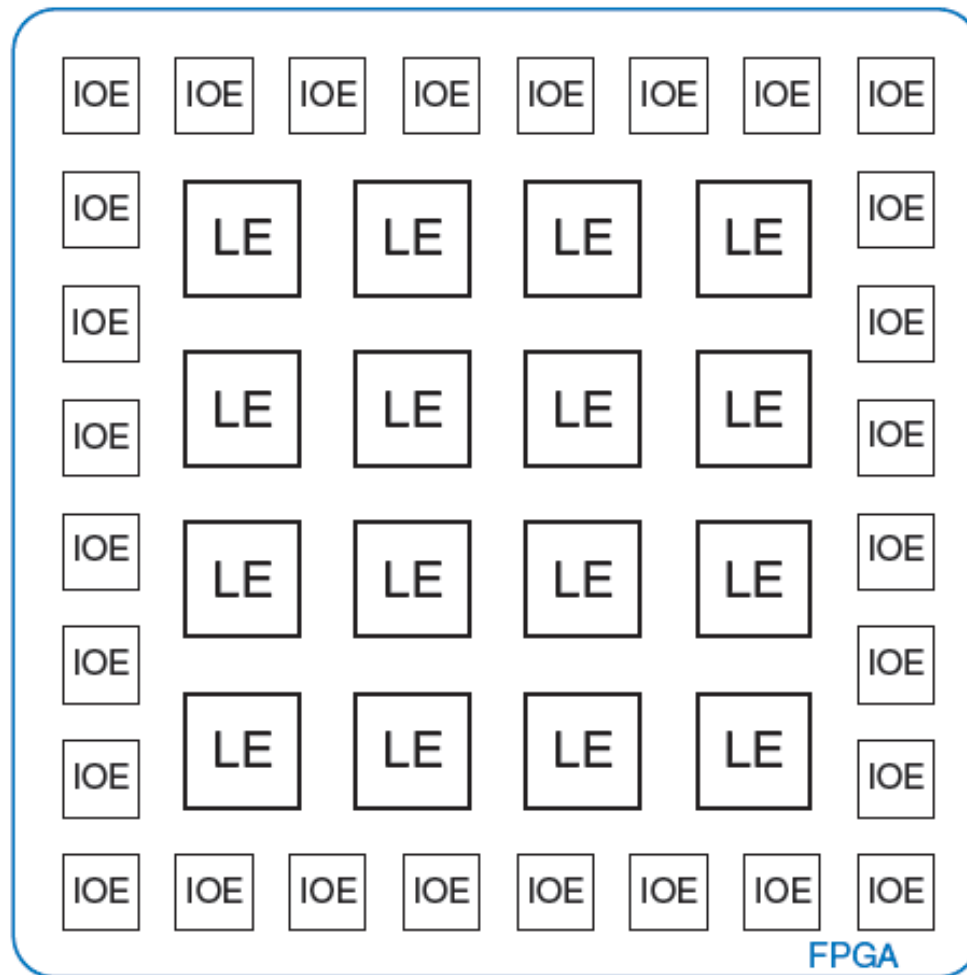

LE: Logic Element

- Composed of:
 - **LUTs** (lookup tables): perform combinational logic
 - **Flip-flops**: perform sequential logic
 - **Multiplexers**: connect LUTs and flip-flops

Altera Cyclone IV LE

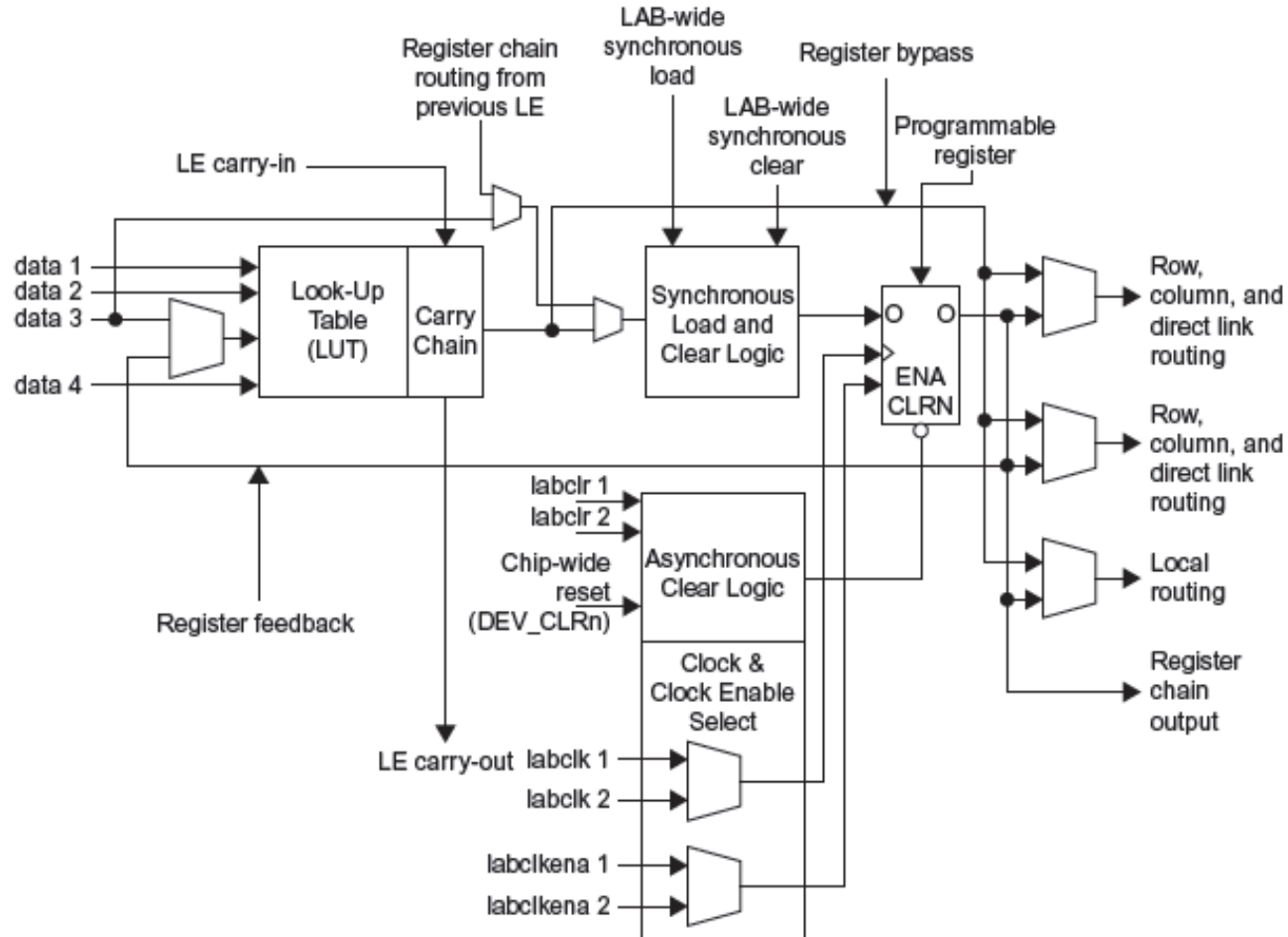

From Cyclone IV datasheet

Altera Cyclone IV LE

- **The Altera Cyclone IV LE has:**
 - 1 four-input **LUT**
 - 1 **registered output**
 - 1 **combinational output**

LE Configuration Example

Show how to configure a Cyclone IV LE to perform the following functions:

- $X = \overline{A}\overline{B}C + A\overline{B}\overline{C}$
- $Y = A\overline{B}$

Logic Elements Example 1

How many Cyclone IV LEs are required to build

$$Y = A1 \oplus A2 \oplus A3 \oplus A4 \oplus A5 \oplus A6$$

Solution:

Logic Elements Example 2

How many Cyclone IV LEs are required to build

32-bit 2:1 multiplexer

Solution:

Logic Elements Example 3

How many Cyclone IV LEs are required to build

Arbitrary FSM with 2 bits of state, 2 inputs, 3 outputs

Solution:

FPGA Design Flow

Using a CAD tool (such as Altera's Quartus II)

- **Enter the design** using schematic entry or an HDL
- **Simulate** the design
- **Synthesize** design and map it onto FPGA
- **Download the configuration** onto the FPGA
- **Test** the design

About these Notes

Digital Design and Computer Architecture Lecture Notes

© 2021 Sarah Harris and David Harris

These notes may be used and modified for educational and/or non-commercial purposes so long as the source is attributed.