

# Lecture 21: Packaging, Power, & Clock

# Outline

- Packaging
- Power Distribution
- Clock Distribution

# Packages

## □ Package functions

- Electrical connection of signals and power from chip to board
- Little delay or distortion
- Mechanical connection of chip to board
- Removes heat produced on chip
- Protects chip from mechanical damage
- Compatible with thermal expansion
- Inexpensive to manufacture and test

# Package Types

## □ Through-hole vs. surface mount

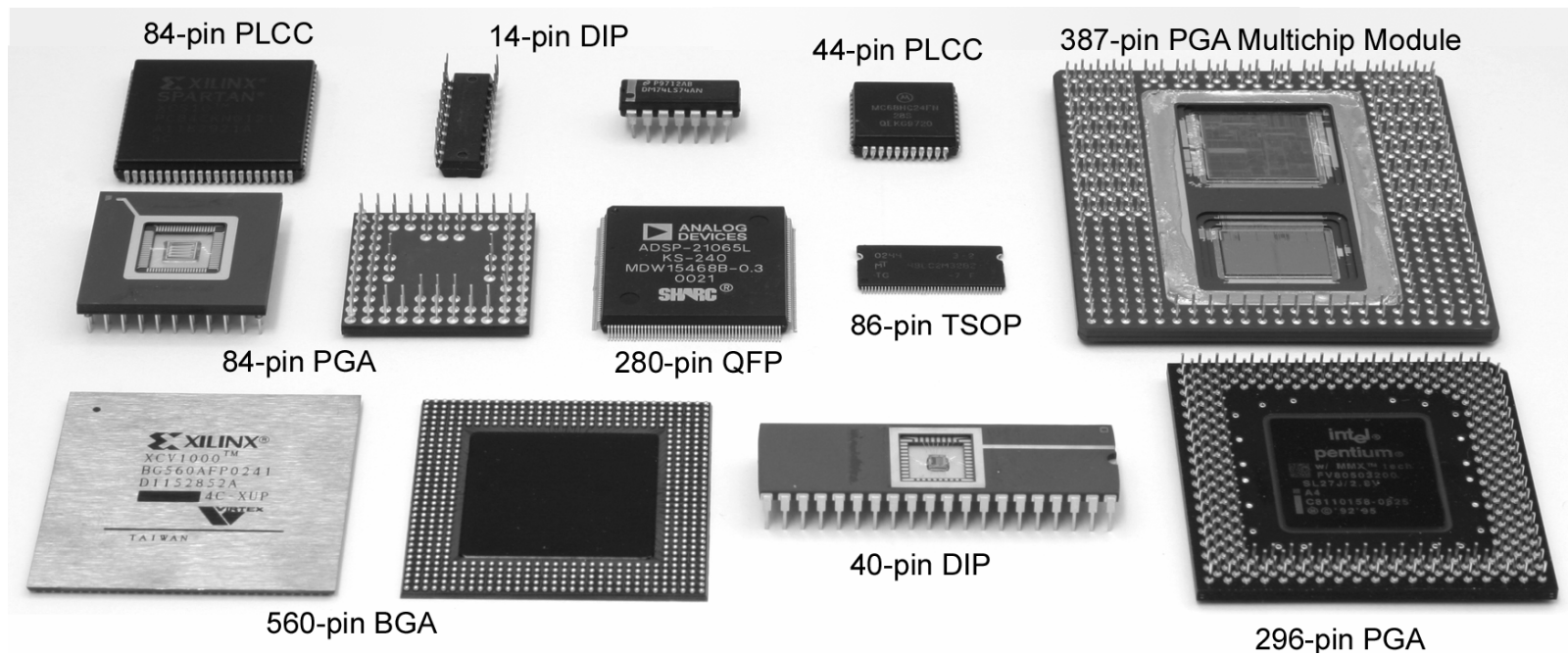

# Chip-to-Package Bonding

- ❑ Traditionally, chip is surrounded by *pad frame*
  - Metal pads on 100 – 200  $\mu\text{m}$  pitch
  - Gold *bond wires* attach pads to package
  - *Lead frame* distributes signals in package
  - Metal *heat spreader* helps with cooling

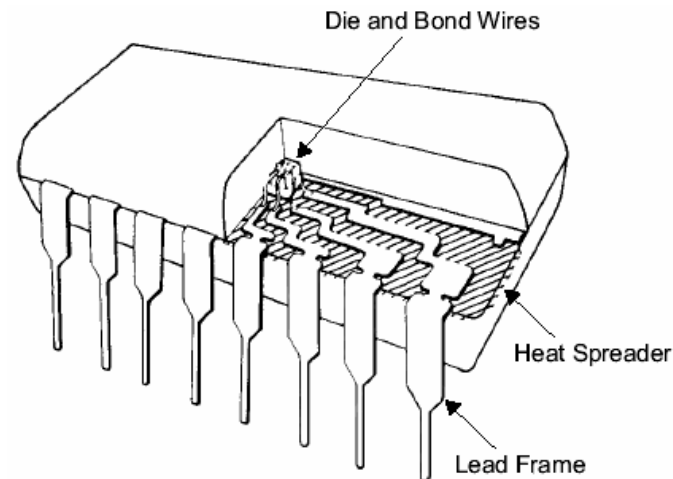

# Advanced Packages

- ❑ Bond wires contribute parasitic inductance
- ❑ Fancy packages have many signal, power layers
  - Like tiny printed circuit boards
- ❑ *Flip-chip* places connections across surface of die rather than around periphery
  - Top level metal pads covered with solder balls
  - Chip flips upside down
  - Carefully aligned to package (done blind!)
  - Heated to melt balls
  - Also called *C4* (Controlled Collapse Chip Connection)

# Package Parasitics

- ❑ Use many  $V_{DD}$ , GND in parallel
  - Inductance,  $I_{DD}$

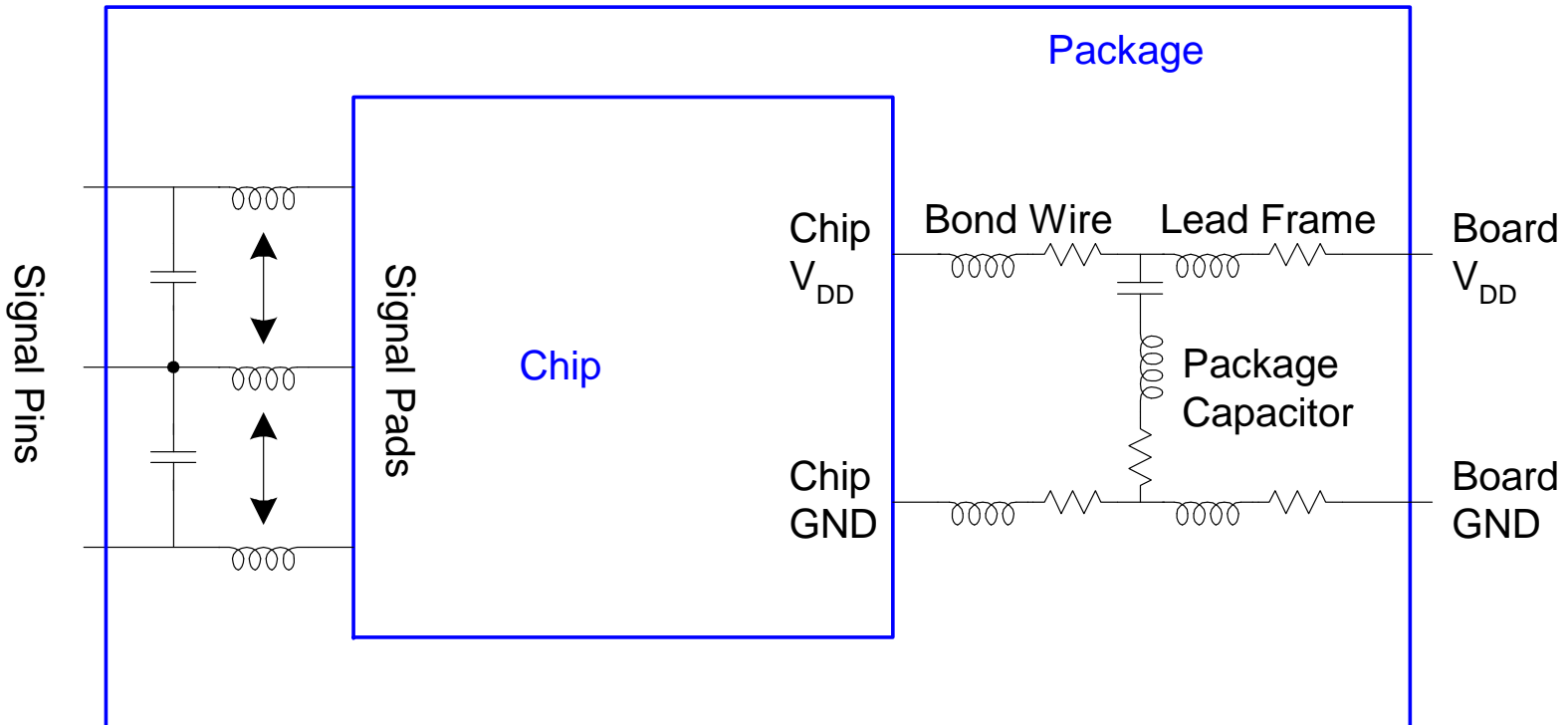

# Heat Dissipation

- ❑ 60 W light bulb has surface area of 120 cm<sup>2</sup>
- ❑ Itanium 2 die dissipates 130 W over 4 cm<sup>2</sup>
  - Chips have enormous power densities
  - Cooling is a serious challenge
- ❑ Package spreads heat to larger surface area
  - Heat sinks may increase surface area further
  - Fans increase airflow rate over surface area
  - Liquid cooling used in extreme cases (\$\$\$)



# Thermal Resistance

- ❑  $\Delta T = \theta_{ja} P$ 
  - $\Delta T$ : temperature rise on chip
  - $\theta_{ja}$ : thermal resistance of chip junction to ambient
  - $P$ : power dissipation on chip
- ❑ Thermal resistances combine like resistors
  - Series and parallel
- ❑  $\theta_{ja} = \theta_{jp} + \theta_{pa}$ 
  - Series combination

# Example

- ❑ Your chip has a heat sink with a thermal resistance to the package of  $4.0^{\circ}\text{C/W}$ .
- ❑ The resistance from chip to package is  $1^{\circ}\text{C/W}$ .
- ❑ The system box ambient temperature may reach  $55^{\circ}\text{C}$ .
- ❑ The chip temperature must not exceed  $100^{\circ}\text{C}$ .
- ❑ What is the maximum chip power dissipation?
  
- ❑

# Temperature Sensor

- ❑ Monitor die temperature and throttle performance if it gets too hot
- ❑ Use a pair of pnp bipolar transistors
  - Vertical pnp available in CMOS

$$I_c = I_s e^{\frac{qV_{BE}}{kT}} \rightarrow V_{BE} = \frac{kT}{q} \ln \frac{I_c}{I_s}$$

$$\Delta V_{BE} = V_{BE1} - V_{BE2} = \frac{kT}{q} \left( \ln \frac{I_{c1}}{I_s} - \ln \frac{I_{c2}}{I_s} \right) = \frac{kT}{q} \left( \ln \frac{I_{c1}}{I_{c2}} \right) = \frac{kT}{q} \ln m$$

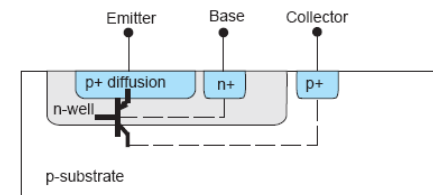
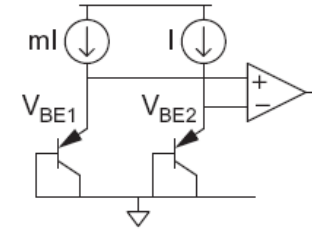

- ❑ Voltage difference is proportional to absolute temp
  - Measure with on-chip A/D converter

# Power Distribution

- ❑ Power Distribution Network functions
  - Carry current from pads to transistors on chip
  - Maintain stable voltage with low noise
  - Provide average and peak power demands
  - Provide current return paths for signals
  - Avoid electromigration & self-heating wearout
  - Consume little chip area and wire
  - Easy to lay out

# Power Requirements

- ❑  $V_{DD} = V_{DDnominal} - V_{droop}$
- ❑ Want  $V_{droop} < +/- 10\%$  of  $V_{DD}$
- ❑ Sources of  $V_{droop}$ 
  - IR drops
  - L di/dt noise
- ❑  $I_{DD}$  changes on many time scales

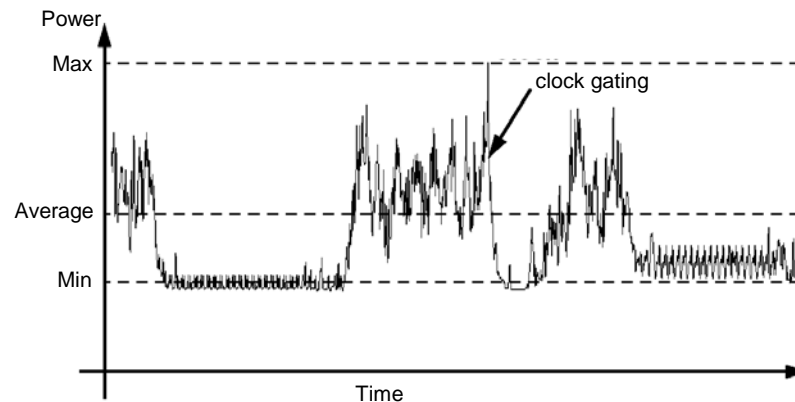

# IR Drop

- A chip draws 24 W from a 1.2 V supply. The power supply impedance is 5 m $\Omega$ . What is the IR drop?
- 
-

# L di/dt Noise

- ❑ A 1.2 V chip switches from an idle mode consuming 5W to a full-power mode consuming 53 W. The transition takes 10 clock cycles at 1 GHz. The supply inductance is 0.1 nH. What is the L di/dt droop?

- ❑
- ❑
- ❑

# Bypass Capacitors

- ❑ Need low supply impedance at all frequencies
- ❑ Ideal capacitors have impedance decreasing with  $\omega$
- ❑ Real capacitors have parasitic R and L
  - Leads to resonant frequency of capacitor

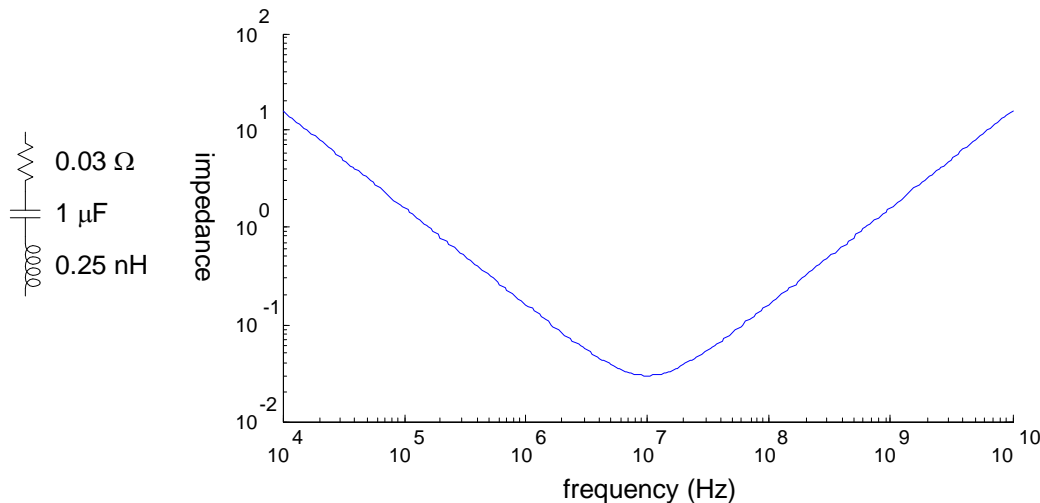



# Power System Model

- ❑ Power comes from regulator on system board
  - Board and package add parasitic R and L
  - Bypass capacitors help stabilize supply voltage
  - But capacitors also have parasitic R and L
- ❑ Simulate system for time and frequency responses

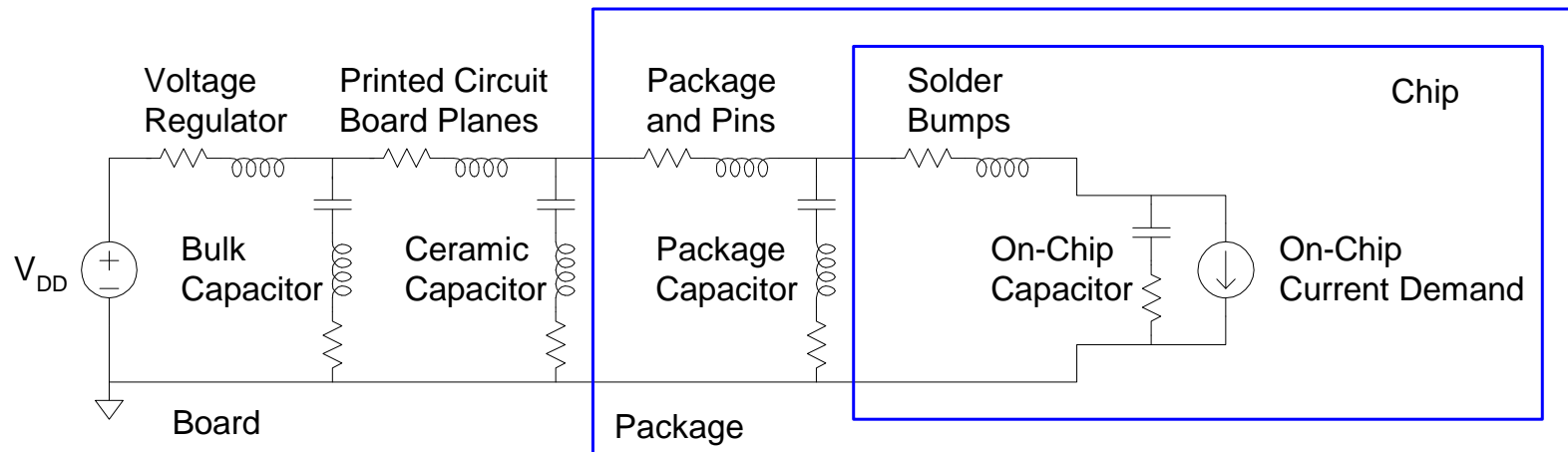

# Frequency Response

- ❑ Multiple capacitors in parallel
  - Large capacitor near regulator has low impedance at low frequencies
  - But also has a low self-resonant frequency
  - Small capacitors near chip and on chip have low impedance at high frequencies
- ❑ Choose caps to get low impedance at all frequencies

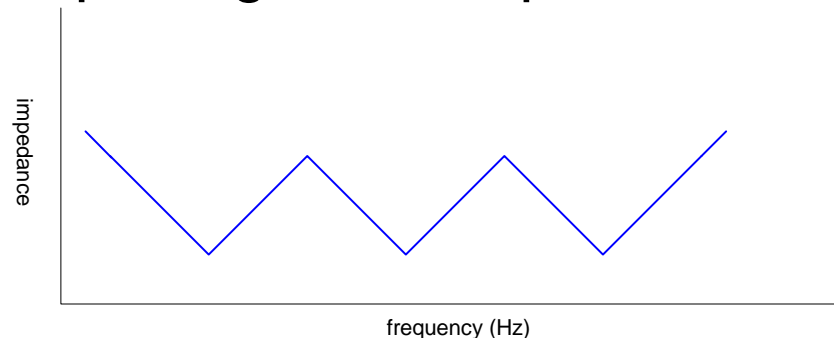

# Example: Pentium 4

- ❑ Power supply impedance for Pentium 4
  - Spike near 100 MHz caused by package L
- ❑ Step response to sudden supply current chain
  - 1<sup>st</sup> droop: on-chip bypass caps
  - 2<sup>nd</sup> droop: package capacitance
  - 3<sup>rd</sup> droop: board capacitance

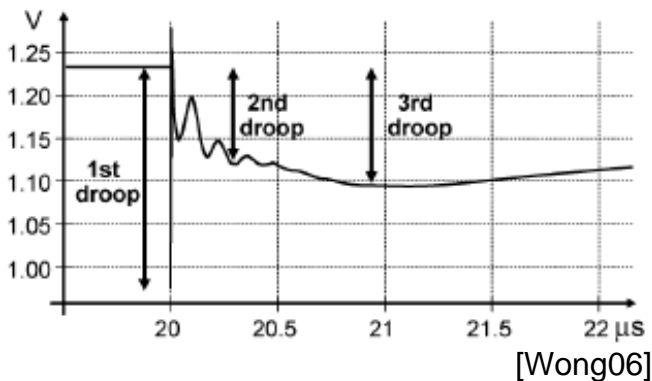
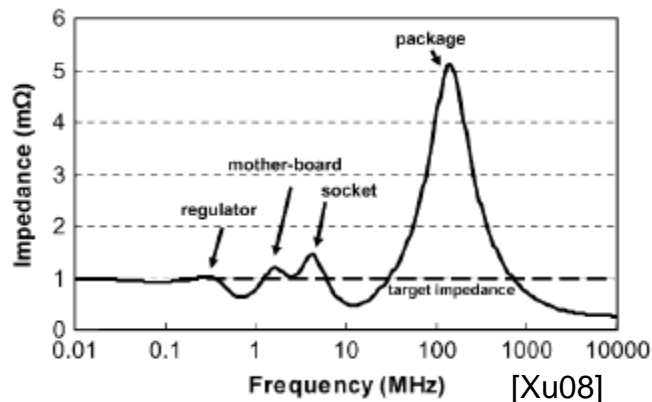

# Charge Pumps

- ❑ Sometimes a different supply voltage is needed but little current is required
  - 20 V for Flash memory programming
  - Negative body bias for leakage control during sleep
- ❑ Generate the voltage on-chip with a charge pump

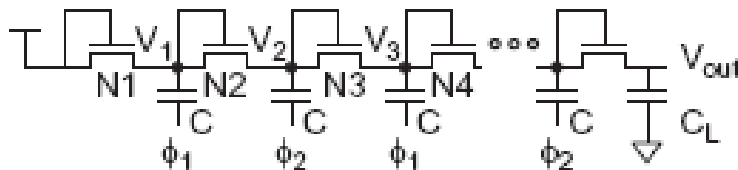

$$V_{\text{out}} = N \left[ \frac{CV_{DD} - \frac{I_{\text{out}}}{f}}{C + C_s} - V_t \right]$$

# Energy Scavenging

- ❑ Ultra-low power systems can scavenge their energy from the environment rather than needing batteries
  - Solar calculator (solar cells)
  - RFID tags (antenna)
  - Tire pressure monitors powered by vibrational energy of tires (piezoelectric generator)
- ❑ Thin film microbatteries deposited on the chip can store energy for times of peak demand

# Clock Distribution

- ❑ On a small chip, the clock distribution network is just a wire
  - And possibly an inverter for clkb
- ❑ On practical chips, the RC delay of the wire resistance and gate load is very long
  - Variations in this delay cause clock to get to different elements at different times
  - This is called *clock skew*
- ❑ Most chips use repeaters to buffer the clock and equalize the delay
  - Reduces but doesn't eliminate skew

# Example

- ❑ Skew comes from differences in gate and wire delay
  - With right buffer sizing,  $\text{clk}_1$  and  $\text{clk}_2$  could ideally arrive at the same time.
  - But power supply noise changes buffer delays
  - $\text{clk}_2$  and  $\text{clk}_3$  will always see RC skew

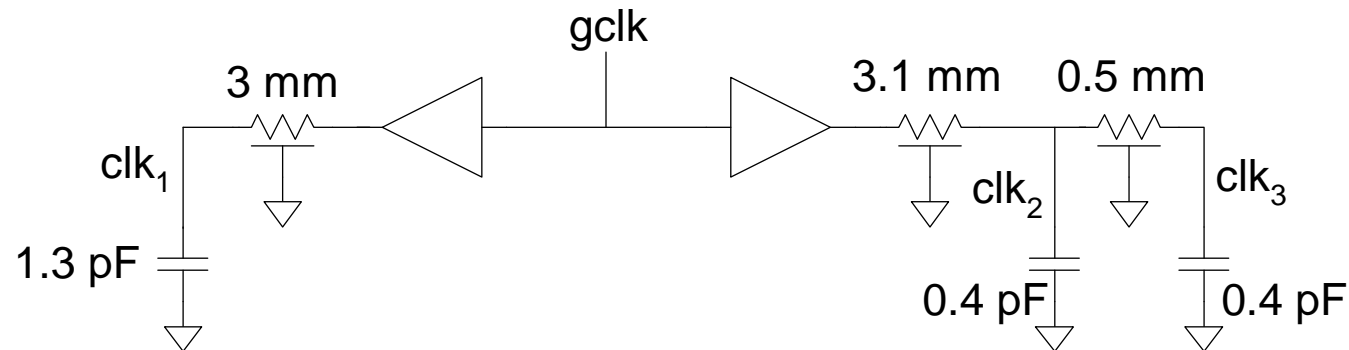

# Review: Skew Impact

- ❑ Ideally full cycle is available for work
- ❑ Skew adds sequencing overhead
- ❑ Increases hold time too

$$t_{pd} \leq T_c - \underbrace{(t_{pcq} + t_{setup} + t_{skew})}_{\text{sequencing overhead}}$$

$$t_{cd} \geq t_{hold} - t_{ccq} + t_{skew}$$

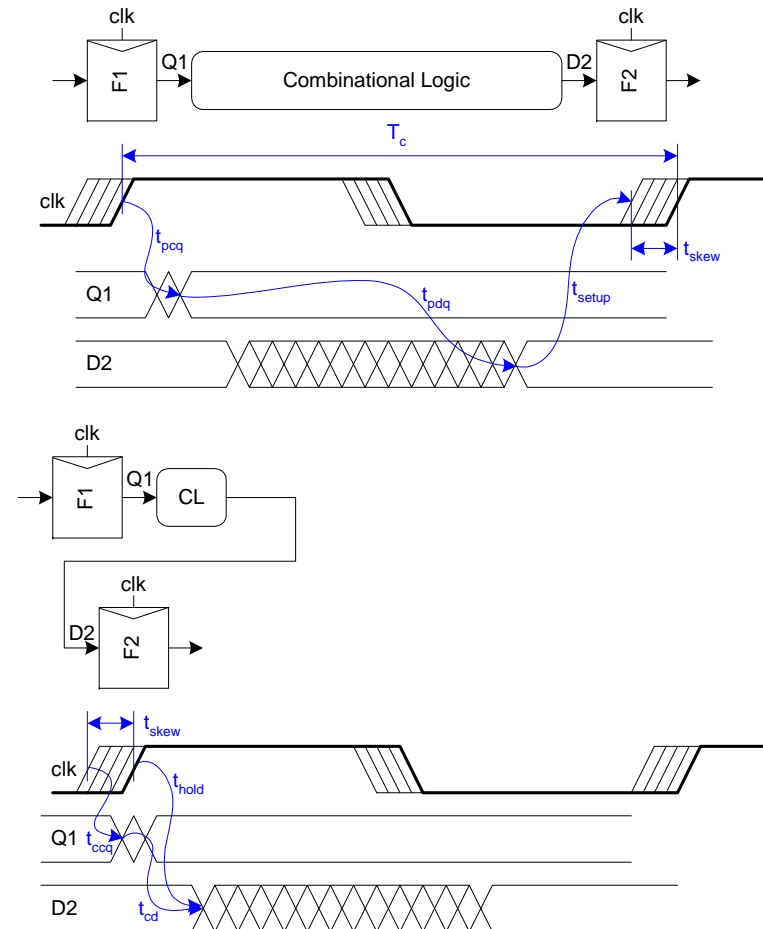



# Solutions

- ❑ Reduce clock skew
  - Careful clock distribution network design
  - Plenty of metal wiring resources
- ❑ Analyze clock skew
  - Only budget actual, not worst case skews
  - Local vs. global skew budgets
- ❑ Tolerate clock skew
  - Choose circuit structures insensitive to skew

# Clock Dist. Networks

---

- Ad hoc*
- Grids
- H-tree
- Hybrid

# Clock Grids

- ❑ Use grid on two or more levels to carry clock
- ❑ Make wires wide to reduce RC delay
- ❑ Ensures low skew between nearby points
- ❑ But possibly large skew across die

# Alpha Clock Grids

Alpha 21064

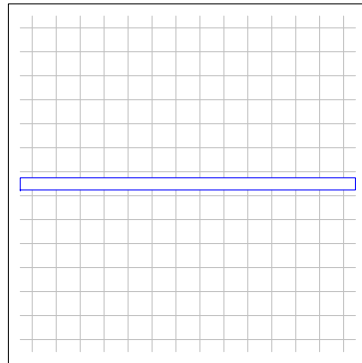

Alpha 21164

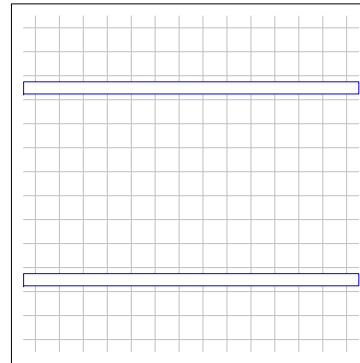

Alpha 21264

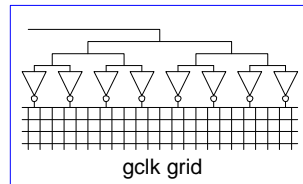
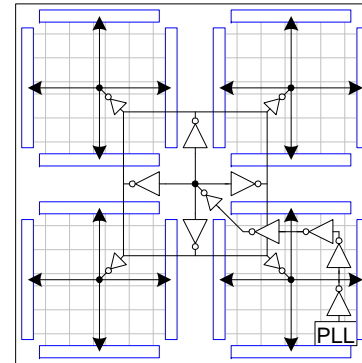

gclk grid

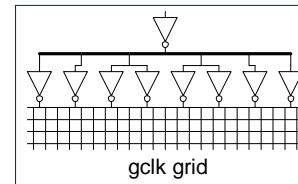

gclk grid

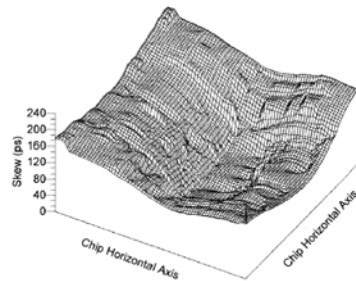

Alpha 21064

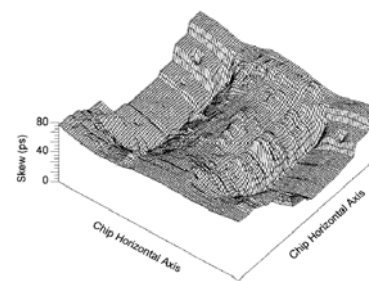

Alpha 21164

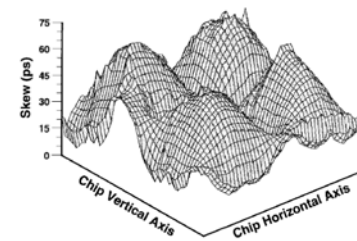

Alpha 21264

# H-Trees

- ❑ Fractal structure
  - Gets clock arbitrarily close to any point
  - Matched delay along all paths
- ❑ Delay variations cause skew
- ❑ A and B might see big skew

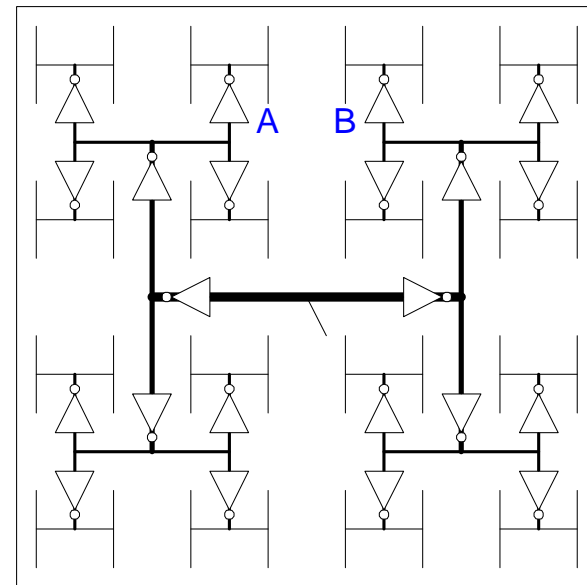

# Itanium 2 H-Tree

- ❑ Four levels of buffering:
  - Primary driver
  - Repeater
  - Second-level clock buffer
  - Gater
- ❑ Route around obstructions

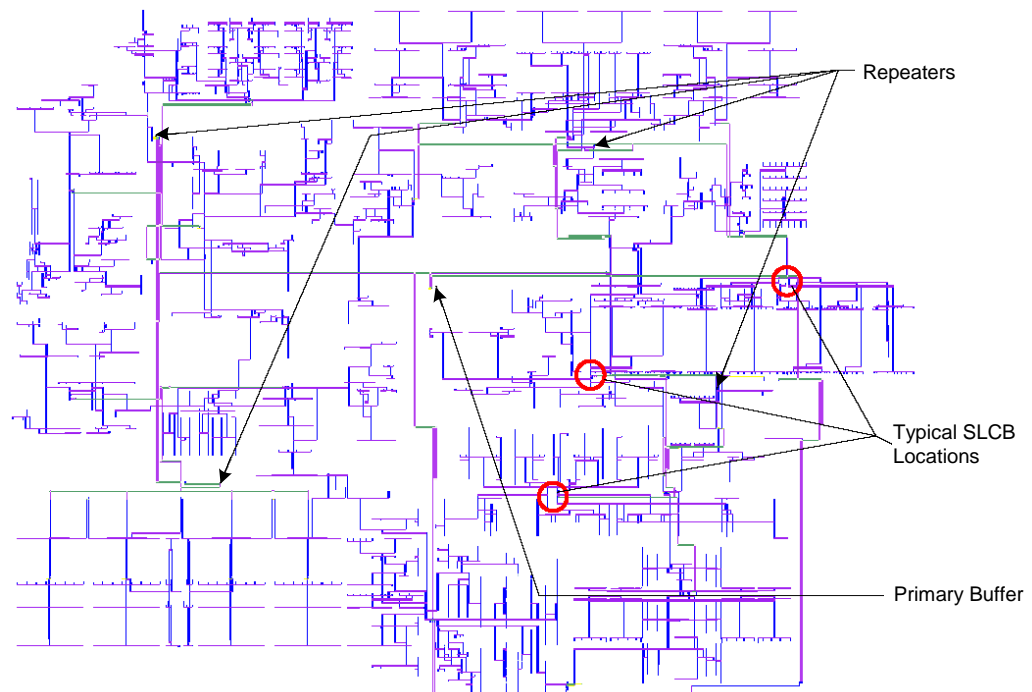

# Hybrid Networks

- ❑ Use H-tree to distribute clock to many points
- ❑ Tie these points together with a grid
  
- ❑ Ex: IBM Power4, PowerPC
  - H-tree drives 16-64 sector buffers
  - Buffers drive total of 1024 points
  - All points shorted together with grid