

1. Consider a BNC cable comprised of a center conductor with outer diameter a and an outer conductor with inner diameter b separated by a dielectric with dielectric constant ϵ and permeability μ . Assume both conductors are infinitely conductive and the dielectric is perfectly non-conductive.

- What are the capacitance per unit length and inductance per unit length of this cable? You may look up this derivation (it's readily available), but you need to replicate it in your answers with enough detail that I believe you understand it.
- What is the impedance of this cable?
- What is the propagation coefficient of this cable, and at what velocity do waves propagate down it?
- Metal losses due to series resistance can be expressed as $R'/(2Z_0)$. Look up an expression for the skin effect and explain how metal losses vary with frequency.
- Dielectric losses can be expressed as $\tan(\delta)Y'Z_0/2$ where Y' is the admittance of the line's capacitor (excluding the conductance, which is modelled as a separate loss) and δ is called the loss tangent (look it up). How do dielectric losses vary with frequency?

2. In this problem we will consider the design of an assortment of planar transmission lines. Assume you are designing a PCB to carry 500MHz signals using the advanced circuits 4 layer stackup (shown below or found at <http://www.4pcb.com/pcb-stack-ups-0.062.html>).

- What is the layer separation of each layer in the stackup?
- What is the thickness of copper on each layer of the stackup?
- Design a microstrip transmission line with an impedance of 50 ohms.
- Design a coplanar waveguide with an impedance of 50 ohms
- Design a stripline with an impedance of 50 ohms.
- What are the maximum and minimum impedances of your lines under the height variations of the stackup shown?
- What is a via fence?
- What is the difference between controlled dielectric and controlled impedance?

Feel free to look up and cite any models that you need. You need to show your work, so you may not simply cite an online calculator.

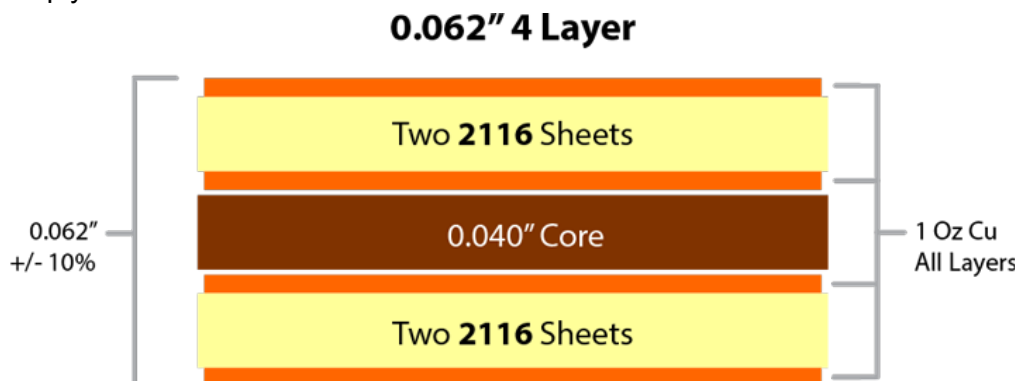

3. In this problem we will simulate wave propagation down a transmission line. Use Matlab (or similar software) to simulate the cases in the table below, which specify the propagation coefficient and the shape of the wave. Plot the wave at 0, 1, 2, 3, 4 and 5 ns. For some parts of this problem, you will need to use Fourier to separate the wave into component sinusoids, apply the propagation equation to each sinusoid, and then combine them again.

Case	α	β	Input Wave
a	0 dB/m	$2/c*\omega$	Cosine wave
b	0 dB/m	$1.3/c*\omega$	1 ns long square pulse
c	0.02 dB/m	$2/c*\omega$	1 ns long square pulse
d	0.1 dB/m	$2/c*\omega$	1 ns long square pulse
e	0.1 dB/m	$4/(c\omega)$	1 ns long square pulse

4. Getting signals into and out of integrated circuits is challenging because the pin of the chip package often has poorly controlled impedance. Consider the integrated circuit diagram and circuit model shown below where C_1 represents the capacitance of the pad for the integrated circuit pin, L_1 represents the impedance of the bond wire, and C_2 represents the capacitance of the pad on the integrated circuit:

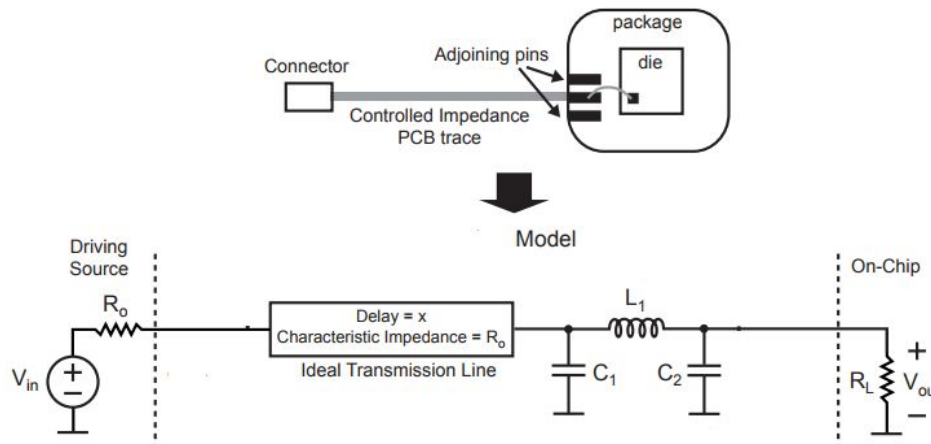

Figure adapted from MIT OCW for 6.776 2005

<https://ocw.mit.edu/courses/electrical-engineering-and-computer-science/6-776-high-speed-communication-circuits-spring-2005/assignments/hw2.pdf>

- If V_{in} drives a 1GHz signal, what is the maximum length of the bond wire at which this model is valid?
- What is the reflection coefficient from the node between the transmission line and the inductor?
- What is the reflection coefficient from the node between the driving resistor and the transmission line?
- What is the propagation coefficient of the transmission line in this model?