

# Lab 2: Reflections on Transmission Lines

In this lab you are going to simulate reflections on transmission lines to predict the types of voltages you would see at drivers, loads and selected points in the middle of a transmission line.

After this lab, you will be able to:

1. Calculate reflection coefficients and voltage distributions on transmission lines.
2. Predict the time scales and shapes of reflection events at the driving point and load of a transmission line
3. Simulate voltages produced at the terminals of a lossless transmission line.

## Practical Questions

1. We have looked at transmission lines in the abstract in our lectures. This round of practical questions will focus on finding examples of transmission lines that are used in the real world. Find pictures and/or cross-sections for each of the following common transmission lines:
  - a. BNC cables (for the record, our BNC cables are of type RG58/U)
  - b. SMA cables
  - c. Microstrip PCB Traces
  - d. (Grounded) Coplanar waveguide PCB traces. It is very rare to see an ungrounded CPWG
  - e. Stripline PCB traces
2. What is loss tangent? Find a calculation relating loss tangent to the real part of the propagation constant. (If it helps, assume the loss tangent is the dominant source of loss in the cable.)
3. FR4 is common material used to make PCBs.
  - a. What is the relative permeability of FR4?
  - b. How does the relative permeability affect the speed of light in FR4?
  - c. How does the relative permeability of FR4 affect the velocity factor of transmission lines built on FR4 PCBs?
  - d. What is the maximum frequency signal that FR4 PCBs can handle and why?
4. What does the word Stackup mean in the context of printed circuit boards? What is the stackup of standard 4-layer printed circuit boards ordered from the manufacturer Advanced Circuits? What effect does the stackup have on transmission lines designed on boards fabricated by Advanced Circuits?
5. Some connectors for RF systems are described by their “electrical length.” What is electrical length? Imagine that you used a connector to attach BNC cables to an oscilloscope, how would you measure the electrical length of the connector if you were uncertain of the velocity in the cables?

## Theory Questions

For these questions, note that BNC cables have a velocity factor of 0.66 and a characteristic impedance of 50 ohms. Note also that function generators almost all have 50 ohms of source impedance.

1. Consider an oscilloscope and function generator connected as shown in Figure 1. Calculate the voltage waveforms you expect to see at channels 1, 2 and 3 after Gen Out drives a 1V step onto the transmission line for the terminations listed below. Discuss both rising and falling edges.
  - a. An open circuit
  - b. 50 ohms.
  - c. A short circuit
  - d. 22 ohms
  - e. 200 ohms

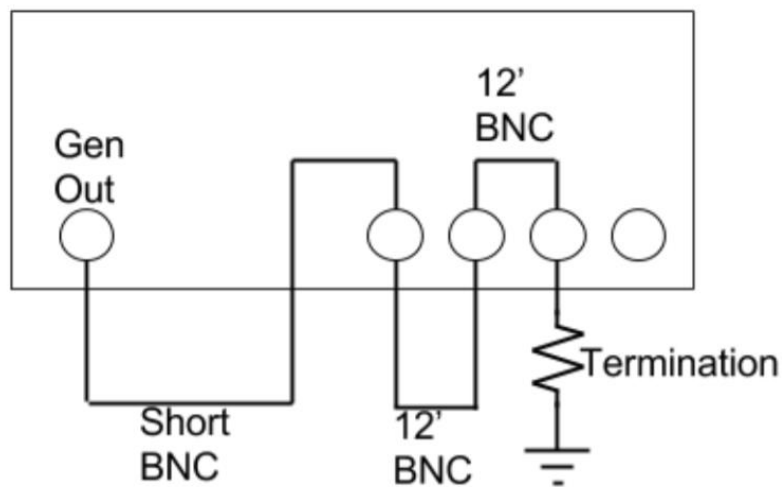

Figure 1

2. Consider an oscilloscope and function generator connected as shown in Figure 2. Calculate the voltage waveforms you expect to see at channels 1, 2 and 3 after gen out drives a 1V step onto the line for the values of shunt and termination resistors listed below. Discuss both rising and falling edges.
  - a. 50 ohm shunt and 50 ohm termination ← hint: think about energy conservation
  - b. 50 ohm shunt and 200 ohm termination ← don't solve this exactly because it's a longwinded pain, a general discussion of what happens at the first few reflections and the point to which the line voltage converges is OK.
  - c. Short shunt and open termination
3. Finally, consider an oscilloscope and function generator connected as shown in Figure 3. Assume the termination is a 22 ohm resistor and the generator is driving a sinusoid.
  - a. What VSWR do you expect on the transmission line?
  - b. If you wanted to sweep the frequency of the input sinusoid to observe the maxima and minima of a standing wave at channel 2, what frequency would you start at and what frequency would you end at? Note this function generator maxes out at 20MHz.

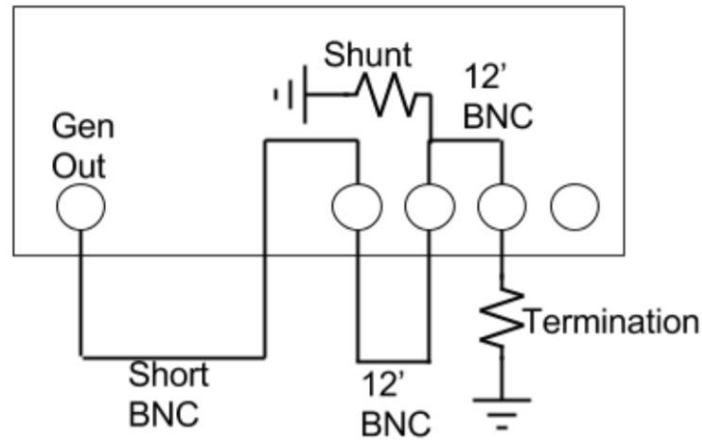

Figure 2

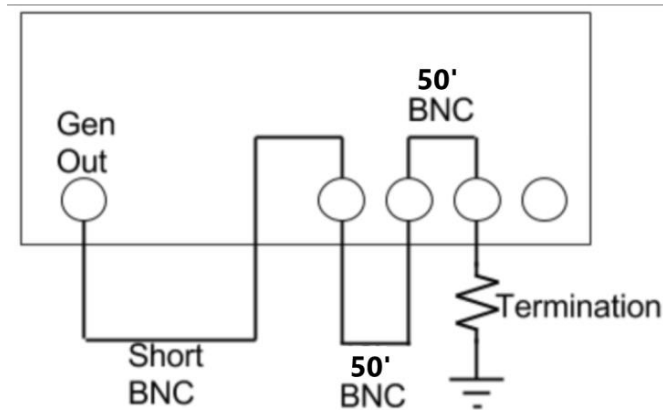

Figure 3

### Lab Instructions

1. Use lossless transmission line elements to simulate the scenarios that you calculated waveforms for in the theory section. Compare your simulation and measurements.
2. Repeat your simulations of Figure 1 using a lossy transmission line element and an appropriate model to set your series resistance to 30milliOhm/m and then 10hm/m. How does this series resistance affect your measured waveforms? These links will help you implement a lossy transmission line model:  
[http://ltwiki.org/index.php?title=O\\_Lossy\\_Transmission\\_Line](http://ltwiki.org/index.php?title=O_Lossy_Transmission_Line)  
<https://electronics.stackexchange.com/questions/323647/ltspice-how-to-model-a-tline>
3. Think of three other features that would make your simulation more realistic. Reflect on the function generator, the elements you use to build the systems like shorts, opens and terminations and other parasitics. Include these features in your model, justify the numbers you select for them, and discuss their effects.

Required data in lab notebook: Schematics of simulations for figures 1, 2 and 3. Time domain traces for each channel on figures 1, 2 and 3, and comparisons to calculated traces from theory section.

Simulations of lossy transmission line and comparison to theory. Simulations of enhanced model and justifications for sizes of elements used in model.