

Figure 1: A full wave rectifier.

## 1 Warm-Up Problems

1. Simulate a diode-resistor circuit
  - (a) Install LTSpice and perform a simulation of a series circuit comprised of a voltage source, a resistor and a forward biased 1N914 diode. Perform a DC sweep of the voltage source from 0.1V to 1.5V in steps small enough to generate a smooth curve and an outer sweep of the resistance value from 100 ohms to 500 ohms in steps of 100 ohms. Plot the resulting I-V relationship with the curve for each resistor value overlaid on the same plot. You may use plots from LTSpice for this assignment, but its generally better practice to export the data and operate on it in software which generates more visually appealing plots. Include the LTSpice schematic you generated. Like the I-V relationship, you may take a screenshot from LTSpice for now. You should develop facility with some external circuit drawing tool (Visio and Illustrator are popular, I use Google Draw) because schematic entry programs produce schematics which are notoriously unreadable on slides.
  - (b) Plot the differential resistance of the diode as well. You may need to export your data from LTSpice to another program to make this plot.
  - (c) Use software of your choice to find a graphical/brute-force/guess-and-check solution to the same circuit for a voltage source of 1.15V and a resistor 326 ohms. (optional) Also use software of your choice to implement an iterative solution to the circuit.
2. The circuit shown in Figure 1 is called a full-wave rectifier.
  - (a) Put the circuit into LTSpice and run a transient simulation of the circuit. Include a screenshot of your simulation result and explain why it is called a full wave rectifier.
  - (b) Full wave rectifiers are often used as power supplies in energy harvesting circuits or when converting from mains power to a DC voltage. In such a use case, a load circuit would be attached between Vout and ground. You can approximate this load as a resistance, which is usually much smaller than 10 kΩ. Use the switch-resistor model of the diode to find a relationship between the value of the load resistance,  $R_l$  ( $\ll 10$  kΩ), and the voltage ripple that is observed in Vout. Instead of using 100 Hz and 10F as the values in your analysis, use the variables  $C$  and  $f$ . It is common to approximate the start of a long exponential tail as linear when making this model.

## 2 Lab Introduction

In this lab we will be characterizing a diode by measuring its I-V behavior over a very wide range of currents. The learning goals are listed below:

1. Observe the exponential I-V relationship of a diode, appreciate that exponentials change fast.
2. Continue to practice the construction of equivalent circuit models for instrument loading.
3. Observe small signal behavior and contrast it to large signal behavior.
4. Practice analog problem solving and creativity to meet the difficult requirements of the lab

## 3 Large Signal Diode Characterization

References: *Horowitz and Hill 44-51, Hays and Horowitz Lab Manual 65-74*

1. Measure the current through and voltage across a forward biased 1N4001 diode at current levels that range from 100pA to 500mA. Doing this will require designing a series of measurement circuits, which are deliberately not provided to you so that you have the chance to design them yourself. Consider instrument loading and precision carefully when you make these designs. You may use resistors from the cabinet and the measurement equipment at your station to build the circuits. You can find 1N4001 diodes in the cabinet and may use 1N914 diodes if the 1N4001 are in short supply.

It is possible that you will be interested in using an operational amplifier to make some of the measurements. A few varieties are available in the cabinet and the stockroom. Think carefully before committing to any op-amp based designs: adding op-amps to your measurement circuits can significantly improve your results, but adding them would be an increase in the complexity of your design. It is possible to take all of these measurements without op-amps.

2. Make a log-linear plot of diode current vs. diode voltage. Explain any deviations from a logarithmic (hence linear on your plot) I-V relationship. Extract the saturation current and non-ideality factor of the diode from the plot. Make sure to document any parameter fitting that was required to make the plot. Include only a few (1-3) data points per decade.

**Required Data:** Schematics of each of your measurement circuits, I-V plot of diode with measured and analytical results overlaid, saturation current and non-ideality factor of diode.

## 4 Small Signal Diode Characterization

Build the circuit pictured in Figure 2 and drive it with a function generator creating a sinusoid with  $V_{pk,pk} = 50\text{mV}$  at an appropriate frequency. Don't forget to model the output resistance of the function generator in your analysis.

1. Plot the amplitude of small signal oscillations,  $v_{out}$ , as you vary  $V_{DD}$  and  $R$  to control  $I_D$ . Select a range for  $I_D$  that shows interesting features of the  $v_{out}$  amplitude vs  $I_D$  curve. Make an analytical model of your expected  $v_{out}$  amplitude and overlay it on the same plot as your measured data. Be sure to describe your design process for selecting  $C$ , the frequency of small signal oscillations  $f$ , and your range of  $I_D$ .
2. Increase the input amplitude to this circuit until the small signal model fails. Compare traces of a wave which operates in a regime where the small signal model works and one where it fails. Use Fourier analysis to analyze the harmonic content of these waves. Propose a limit on signal amplitude under which small signal models are accurate. It is helpful to watch harmonic content of your waves in real time using the FFT function of the oscilloscope.

**Required Data:** Plot of  $v_{out}$  vs.  $I_d$ . Scope traces comparing small signal model working vs. not working. A proposed maximum amplitude for small signals.

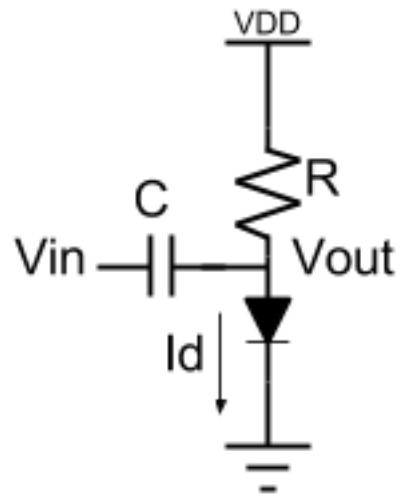

Figure 2: An input signal AC coupled into a resistor diode circuit used for Part 4.