

Figure 1: A sample design for a differential amplifier and a Poor Man's Balun.

1 Warmup Problems

1. What are the values of v_{O+} and v_{O-} ? Assume r_o of all devices and R_t are infinite and that $\beta = 100$.
2. What is the maximum differential linear input range for each stage? What is the maximum differential output swing for each stage? Will this amplifier clip?
3. Is this amplifier gain inverting or non-inverting? How would you switch the sign of the gain?

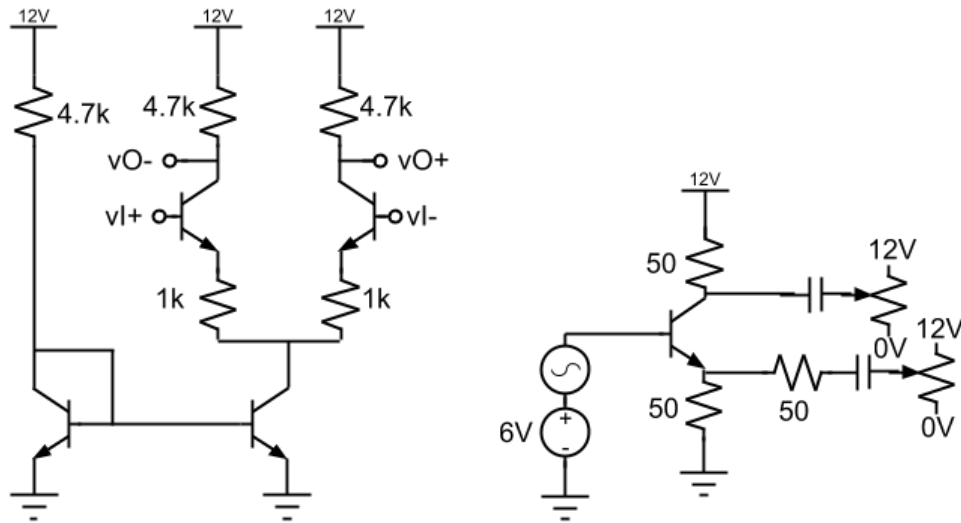

Figure 2: A sample design for a differential amplifier and a Poor Man's Balun.

2 Lab Introduction

In this lab you will build and characterize a differential amplifier. The learning goals are listed below:

- Observe the use a current mirror to create a tail current which, in turn, sets the amplifier's bias point.
- Become familiar with the analysis a differential amplifier.
- Familiarize yourself with the definition and measurement of differential design specifications.

IMPORTANT NOTE: This is the first stage of your operational amplifier. Please keep it on your breadboard for use in future labs.

3 Build and Measure a Differential Amplifier

Calculate and measure I_T , $r_{in, dm}$, $r_{out, dm}$, a_{dm} , $r_{in, cm}$, $r_{out, cm}$, a_{cm} , $CMRR$, $PSRR$, and I_{TN} for the differential amplifier pictured in Figure 2. Also, measure the input-referred and output-referred offset voltages of your amplifier. Be sure to adjust your bias point to account for the offset before measuring small signal parameters.

One of the great nuisances of differential amplifier tests is the need to create a two tricky small signal inputs: the differential inputs v_{ip} and v_{in} and the power supply input used to find the $PSRR$. Make the differential inputs using the poor man's balun in Figure 2. Use potentiometers to set the base voltages of your emitter coupled pair because you will need to trim them to find your amplifier's offset voltages.

You can add a small signal voltage ripple to the power supply by capacitively coupling onto V_{CC} from the signal generator.

Required Data: Calculations for listed parameters, measurements for listed parameters with descriptions of experimental setups, comparison of calculated and measured values with discussions of discrepancies (or ideally no discrepancies). Descriptions of experimental setup should include balun (even though it's given to you here). Measured offsets. Actual bias point used during final test including any CM offset you choose to add.