

# **Digital Design and Computer Architecture (E85)**

J. Spjut & R. Wang

Spring 2013

**Problem Set 8**

**Due: 4/15/2013**

## **1) Textbook Problems**

Do problems 7.13-c,d, 7.19, 7.23. For Exercise 7.19 use the instruction mix from Example 7.7.

## **4) Time**

Please indicate how many hours you spent on this problem set. This will not affect your grade (unless completely omitted), but will be helpful for calibrating the workload for next semester's class.

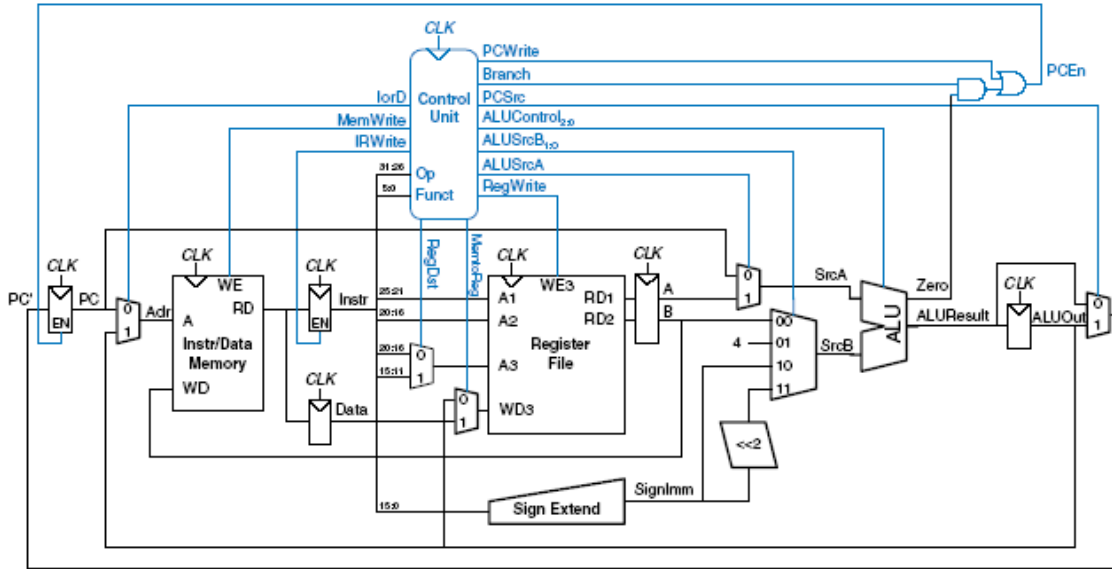

Figure 7.27 Complete multicycle MIPS processor

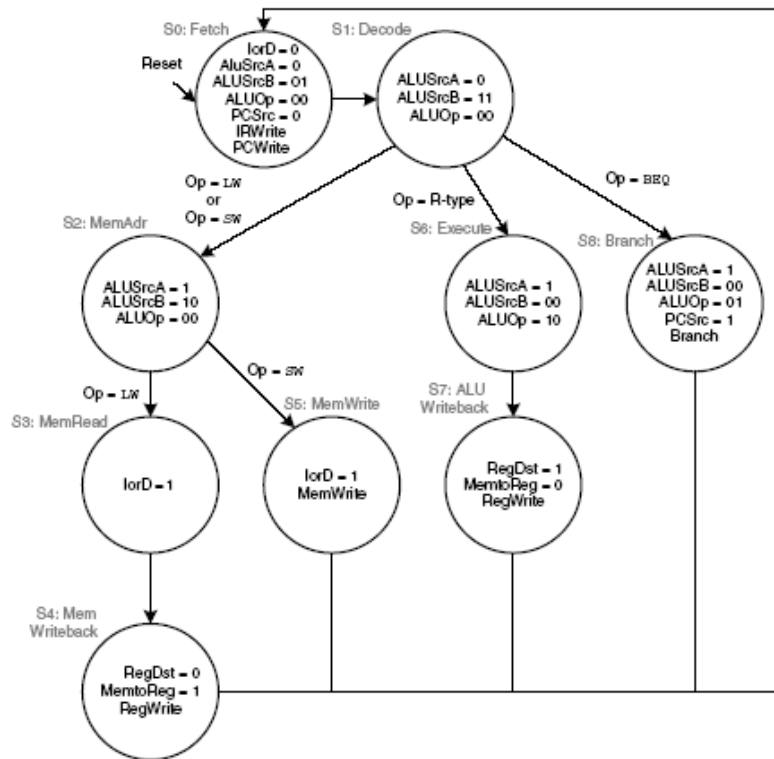

Figure 7.39 Complete multicycle control FSM

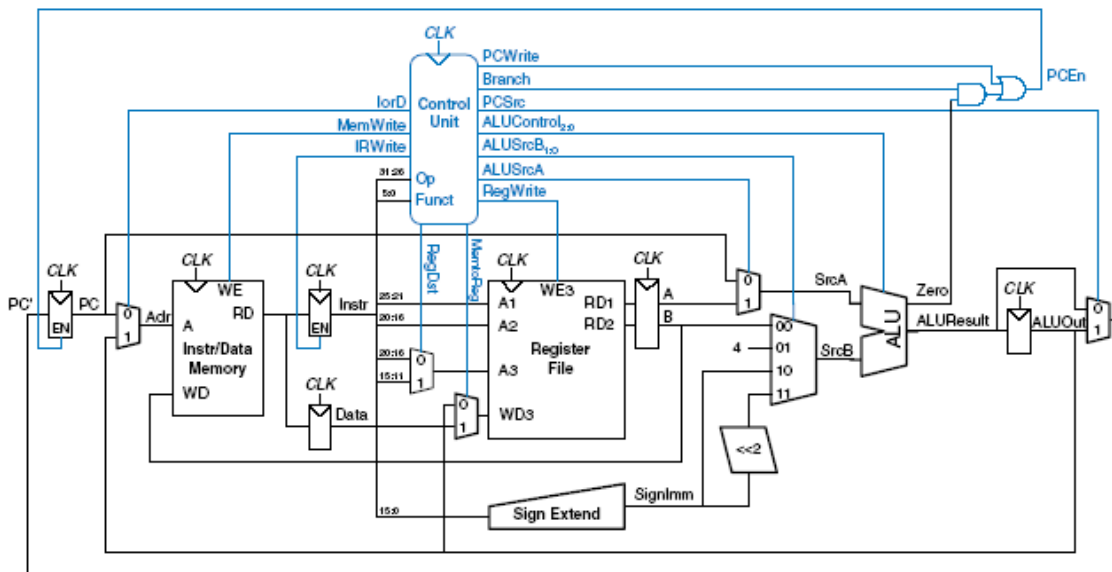

Figure 7.27 Complete multicycle MIPS processor

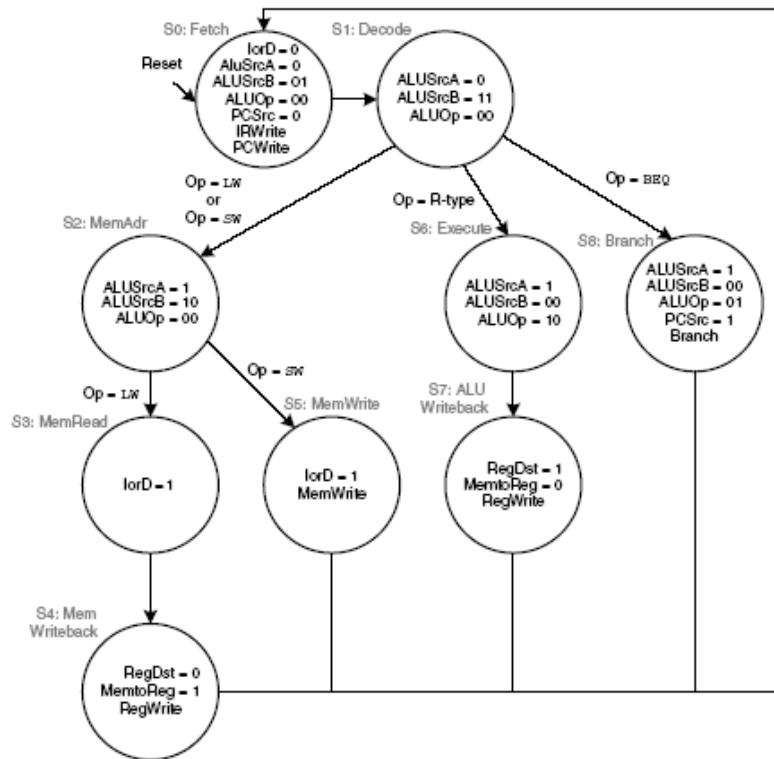

Figure 7.39 Complete multicycle control FSM