

# Microprocessor-Based Systems (E155)

J. Spjut and M. Spencer

Fall 2014

## Lab 3: Keypad Scanner

### Requirement

*Design and construct a circuit to read a 4-by-4 matrix keypad. Display the last two hexadecimal digits pressed on your dual seven-segment display, with the most recent entry appearing at the right. Each key press should be recorded exactly once, at the time the key is depressed, no matter how long or short a time the user holds the key down. If multiple keys are pressed, the system can do anything graceful, but should not lock up.*

### Discussion

A matrix keypad has four rows and four columns, connected to 8 pins, as shown below for two different models. When you press a key, the corresponding row and column are connected. Check this with a multimeter to confirm your pinout.

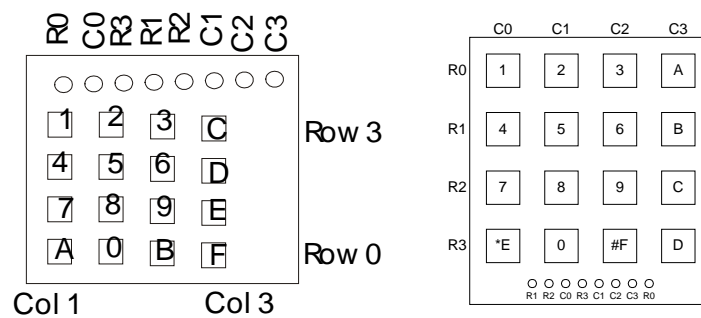

Figure 3.1: Keypad Pinouts

Mechanical switches are prone to a phenomenon called switch bounce, where the switch makes and breaks its connection repeatedly on a time scale of microseconds to a few milliseconds. You should design your system in such a way that a single keypress registers only once even if there is some momentary bounce.

This is a thinking person's lab. If you thoroughly understand the problem and design a simple scanner circuit, you can complete the lab fairly efficiently. If you go by trial and error, you may find yourself in lab indefinitely. You will need to generate rather complex stimulus to simulate your keypad scanner. Many students have been tempted to skip simulating and debug on the real hardware. Almost all have regretted it. Similarly, some students have been lured down the path of asynchronous design, at their peril.